



Assembly instructions



MBB F 1000 L (former: 1000 Twinfold)

1. Please check before assembly

1. Does the delivery correspond with your order?
2. Is the installation drawing corresponding to the type present?
3. Does the operating voltage of the loading tailgate correspond with that of the vehicle?
4. Insofar as there is an attachment proposal present, check that it is correct, and also the vehicle dimensions and installation drawing.
5. Is a double floor (wear floor) to be installed?
If yes then set the platform and the HAP higher.
6. When folding in and out 25 mm finger clearance is required between the platform and the lower edge of the HAP.
7. With trailer operation, check for freedom of movement of the drawbar.
8. It is essential that the vehicle manufacturer's attachment guidelines be adhered to.

Preparatory work on the chassis

Install subframe if required. See vehicle manufacturer's attachment guidelines.
Arrange chassis and subframe in accordance with installation drawing and MBB attachment proposal.

Note !

Special tools such as assembly equipment, installation gauge, coil tester, pressure manometer etc. can be acquired from **PALFINGER Tail Lifts** on request.

3. Assembly of loading tailgate with rear connection profile as assembly equipment

1. There are assembly holes in the web plates of the HAP.
2 pieces of round steel bar are required $\varnothing 28 \times 500$ mm long (not part of the **PALFINGER Tail Lifts** delivery).
2. Bolt on the torsion arms by means of the round bar steel and the assembly holes and check the side alignment to the installation.
3. Position the height of the stand in accordance with the installation drawing.
Ensure the largest possible amount of ground clearance and freedom of movement of all parts.
4. Turn the stand such that it is parallel to the installation.
5. Fasten the loading tailgate to the vehicle chassis by means of bracket plates, per the installation drawing and vehicle manufacturer's attachment guidelines.
6. Remove round bar steel

ATTENTION! Torsion frame can swing down as there is not yet enough oil in the lifting cylinder.

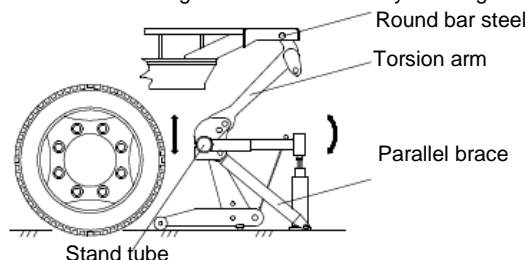

2. Rear connection profile (HAP)

1. Shorten HAP equally on both sides to suit installation width.
2. Arrange free space in the loading area for assembly of the HAP, note door seals where necessary.
3. The HAP forms the end of the loading area.
4. Install the HAP flush with the load area.

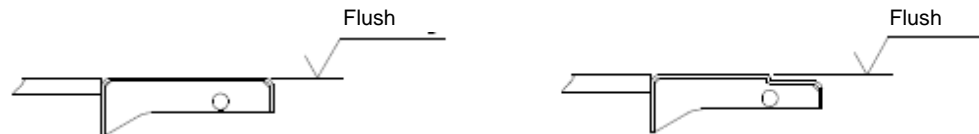

5. Weld the HAP in accordance with the roll-over weights.
We recommend a bracing of the subframe / chassis frame with strong gusset plates, particularly in the area of the HAP reinforcing plates.

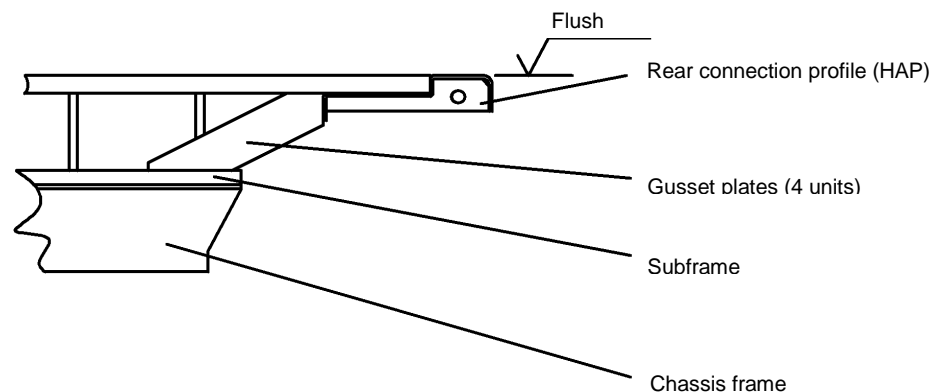

4. Installation of electrics

1. Use the associated wiring diagram, which is located in the sealing cap on the right (in the direction of driving), and observe the vehicle manufacturer's attachment guidelines.
2. Feed battery cable to the battery, shorten if necessary and install cable lug.
3. Install main fuse with cable lug and connect to the positive terminal of the battery.
4. Lay the controller cable through to the driver's cab. In the driver's cabin select a place on the instrument panel, establish electrical connections per wiring diagram and install control unit.
5. If there is already a controller available in the vehicle then connect the loading tailgate in accordance with the supplementary wiring diagram - request wiring diagram from **PALFINGER Tail Lifts** if necessary.

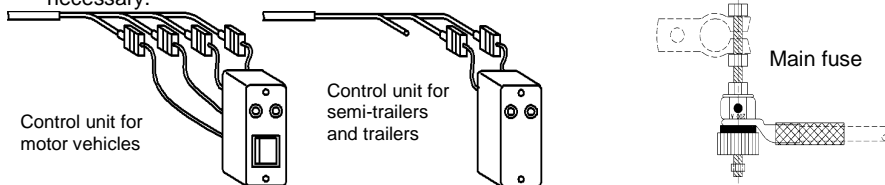

6. Connect the earth connection in accordance with the vehicle manufacturer's attachment guidelines.
7. **ATTENTION!** With hazardous goods vehicles, connect the earth cable to the battery or in accordance with the respective vehicle manufacturer's attachment guidelines.
8. Weld or fasten the control panel into place in accordance with the installation drawing.
9. **Note the following when attaching a manual cable switch.** Install the cable with terminal box under the HGV loading area such that it is possible to make a connection from the cable there to the manual cable switch. Connect the cable from the manual cable switch in the terminal box in accordance with the wiring diagram. Find a suitable and secure storage location for the manual cable switch.
10. **Operation of the manual cable switch only permissible from the marked position on the platform.**

5. Assembly of the platform (mounted by PALFINGER Tail Lifts)

1. Remove the oil tank plug screw and replace with the air filter provided.
2. Let the lifting mechanism down via the side control panel until the platform can be mounted.
3. With suitable lifting apparatus, bolt the platform to the torsion frame and parallel braces. Install the torsion springs, swing the platform into horizontal position and lower it to the ground.
4. Fold in platform spikes and platform and lean against the roller on the under-ride protection.
5. Raise the platform far enough that the surface of the tunnel is horizontal.
6. Now connect the parallel brace with the joint. Use the bolt, the spacer sleeve and the washer for this.
7. Lower the platform until the bolt can be pushed through. **Caution, collision hazard**
8. Fasten bolt and install support roller.
9. Slowly raise the platform until the stirrup bolt is loose and then remove this.
10. Gas pressure spring is now ready for operation.

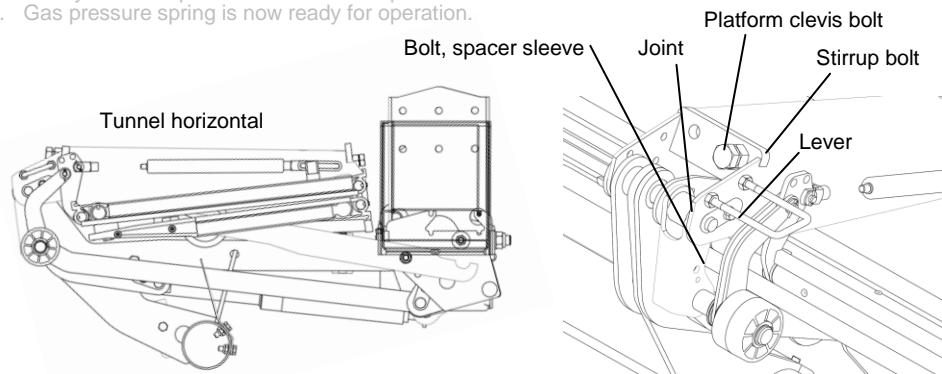

6. Adjustment and installation work prior to commissioning

1. Swing the platform into the HGV driving position and adjust the buffer stop such that the platform lies on the buffer.
2. Install the two other buffer stops on the installation depending on location, such that the platform does not jump when the HGV is driving.
3. Install switch b13 or b16 on the platform as shown.
4. Remove the three connectors for the footswitch (not with basic) and Warnfix from the platform and connect to the connectors coming from the control rod (yellow cable tie with yellow line, black with black and the indicated cable ties with the designated connectors) and then insert the thus-connected connectors back into the loading flap again and install the strain relief.
5. Fasten the cable securely to the control rod with cable ties. Check for freedom of movement for the platform and ensure appropriate cable lengths for this.
6. All cables installed must be carefully laid and securely fastened. Sufficient bending lengths must be observed.
7. Drive the platform upwards and remove the transport securing screws on both mechanical joints.
8. Lift, lower, fold in and fold out the platform several times in order to bleed the cylinder.
9. Let the platform rest on the ground and lower the platform spikes. Adjust switch b13 or b16 as shown and tighten the adjusting screw. Bring the platform to the HGV driving position and check whether the warning lamps extinguish with the control unit in switched off condition. Correct again if required, fold back fuse panel.
10. Carry out oil level check with platform lowered, check all implemented screwed connections for tight seating per installation drawing. Carry out acceptance test per test book and record in test book.
11. Perform 125% overload test at load centre according to control booklet (page 9)
12. **Set platform tip 60mm above floor height by adjusting the platform clevis bolts.**

