

PALFINGER

PALFINGER TAIL LIFTS

OPERATING MANUAL TAIL LIFTS

LIFETIME EXCELLENCE



Operating manual
for
PALFINGER Tail Lifts tail lift

Standard tail lifts
Retractable tail lifts
Foldable tail lifts

Translation of the original operating manual

Table of contents

1. PALFINGER Tail Lifts – The tail lift.....	10
2. About this manual.....	11
2.1. Further documentation	11
2.2. Important safety information	11
2.3. Intended use.....	12
2.4. Personnel qualifications.....	13
2.5. Warnings in this manual	13
2.6. You must observe the following.....	14
2.6.1. General information.....	14
2.6.2. When switching on	14
2.6.3. During operation.....	15
3. Supplied as standard.....	16
4. Model overview	17
5. How to find your model	22
5.1. Standard tail lifts	22
5.2. Retractable tail lifts	23
5.3. Foldable tail lifts.....	23
5.4. Ambulance models.....	24
6. Pre-setting the tail lift	25
6.1. Adjusting the ground alignment time	25
6.2. Pre-setting the platform tilt.....	26
6.3. Adjusting tilt sensor B15S.....	27
6.4. Adjusting the pressure switch on the hydraulic stabilizer feet	29
6.5. Calibrating the controller.....	30
6.6. Adjusting the BDF position	30
6.7. Programming the button code on the Slimpanel.....	32
7. General operation	33
7.1. Switching the tail lift on	34
7.2. Extending the stabilizer feet on your vehicle	36
7.3. Retracting the stabilizer feet on your vehicle	37

7.4.	Moving the platform	38
7.4.1.	Definitions of terms.....	39
7.4.2.	Opening/unfolding/extending the platform and adjusting the platform tilt.....	40
7.4.3.	Lowering the platform.....	40
7.4.4.	Lifting the platform.....	41
7.4.5.	Closing/folding in/retracting the platform	41
7.5.	Operating the platform lock.....	42
7.6.	Setting up and taking down the platform railing	42
7.7.	Roll stop.....	45
7.7.1.	Operation via the knurled wheel	45
7.7.2.	Operation via the bolt	46
7.7.3.	Operating a self-erecting roll stop.....	46
7.8.	Loading or unloading the platform	47
7.8.1.	Loading or unloading the platform on the ground	48
7.8.2.	Loading or unloading the platform on a ramp	48
7.9.	Switching the tail lift off	50
8.	Operation.....	52
8.1.	Side control.....	52
8.1.1.	Operation via the two hand control.....	53
8.1.2.	Operation via the Slimpanel	55
8.1.3.	Operation via the two hand control without automatic ground alignment	57
8.1.4.	Operation via the two hand control and hydraulic stabilizer feet.....	59
8.1.5.	Operation via the two hand control and hydraulic underride guard.....	61
8.1.6.	Operation via the Slimpanel and hydraulic underride guard	63
8.1.7.	Operation via the one hand control	65
8.1.8.	Operation via the one hand control and hydraulic stabilizer feet.....	67

8.1.9. Operation via the Slimpanel and hydraulic stabilizer feet	69
8.1.10. Optional: Quick down with two hand control.....	71
8.1.11. Optional: Quick down (with Slimpanel).....	72
8.1.12. Operation via the two hand control.....	73
8.1.13. Operation via the Slimpanel	75
8.1.14. Operation via the easy move® two hand control....	77
8.1.15. Operation via the easy move® one hand control ...	79
8.1.16. Operation via the easy move® Slimpanel	81
8.1.17. Operation via the two hand control for R 1500 L FLAT	83
8.1.18. Operation via the one hand control for R 1500 L FLAT	85
8.1.19. Operation via the Slimpanel for R 1500 L FLAT	87
8.1.20. Operation via the two hand control for R 1500 SH – R 2000 LH (double-folding platform).....	89
8.1.21. Operation via the Slimpanel for R 1500 SH – R 2000 SH	92
8.1.22. Operation via the two hand control for R 750 SM – R 2000 LM (double-folding platform).....	95
8.1.23. Operation via the Slimpanel for R 750 SM – R 2000 LM (double-folding platform).....	98
8.1.24. Operation via the easy move® two hand control for R 750 SM – R 2000 LM (double-folding platform)	101
8.1.25. Operation via the easy move® Slimpanel for R 750 SM – R 2000 LM (double-folding platform).....	104
8.1.26. Operation via the two hand control.....	107
8.1.27. Operation via the one hand control	109
8.1.28. Operation via the Slimpanel	111
8.1.29. Operation via the two hand control.....	113

8.1.30.	Operation via the one hand control	115
8.1.31.	Operation via the Slimpanel	117
8.2.	Optional operating possibility: Foot control	119
8.2.1.	Platform with 2 foot controls	119
8.2.2.	Platform with 3 foot controls	120
8.3.	Optional operating possibilities: Hand cable control and radio remote control	121
8.3.1.	Hand cable control with two pushbuttons	123
8.3.2.	Hand cable control with three pushbuttons	124
8.3.3.	Remote Control BT radio remote control	125
8.4.	Special operating elements	127
8.5.	Special operating elements	128
8.6.	Special operating elements	130
8.7.	Special operating elements for hydraulic stabilizer feet	132
8.8.	Hand pump operation for C 1000 LX ambulance – C 1500 SX ambulance	133
9.	Service and maintenance	135
9.1.	Before maintenance	136
9.2.	Relieving springs	136
9.3.	When disposing	136
9.4.	Maintenance intervals	137
9.5.	Daily maintenance	138
9.5.1.	Checking safety and warning equipment	138
9.5.2.	Checks during operation	138
9.6.	Maintenance depending on the usage frequency	139
9.6.1.	Cleaning the tail lift	139
9.6.2.	Checking the battery	140
9.6.3.	Checking the carbon brushes on the electric motor	140
9.6.4.	Checking/restoring platform markings	140
9.7.	Monthly maintenance	140
9.7.1.	When the vehicle is stopped: Checking the platform position	140

9.7.2. Checking the bellows	141
9.7.3. Checking the oil level	141
9.7.4. Checking the screw connections and lines on the hydraulic system.....	142
9.7.5. Checking that the bolts and nuts are tight	142
9.7.6. Checking the weld seam on the head profile.....	143
9.8. Quarterly maintenance or maintenance every six months.....	143
9.8.1. Moving the tail lift.....	143
9.8.2. Lubricating the bearings on the tilt and lifting cylinders.....	143
9.8.3. Lubricating the movement rails (only retractable tail lifts)	144
9.9. Annual maintenance	144
9.9.1. Replacing the hydraulic oil	144
9.9.2. Checking all weld seams	148
9.10. Maintenance every four years	149
9.10.1. Replacing all hydraulic hoses	149
9.11. Resetting the service counter (maintenance counter)	150
10. Inspections	151
11. Faults	152
11.1. Service partners	152
11.2. Prior to troubleshooting	152
11.3. Troubleshooting.....	153
11.4. Fault detection via the 7-segment display	154
11.5. Fault assistance tables	157
11.6. Emergency operation	167
11.7. Emergency operation: Closing the platform if all controls fail.....	168
11.8. Emergency platform opening in the event of a fault.....	170
12. Technical data	173
12.1. Recommended battery capacity	173
12.2. Alternators to recharge the battery	173

12.3. Temperature range for using the tail lift	173
13. Load diagrams	174
13.1. Standard tail lifts	176
13.2. Standard tail lifts – van models	177
13.3. Retractable tail lifts Single-folding platform.....	177
13.4. Retractable tail lifts Double-folding platform	179
13.5. Foldable tail lifts Four-cylinder models.....	179
13.6. Foldable tail lifts Two-cylinder models	180
14. Hydraulic circuit diagrams	181
14.1. Standard tail lift with four cylinders	181
14.2. Standard tail lift with soft levelling	182
14.3. Standard tail lift with two cylinders	183
14.4. Standard tail lift with hydraulic stabilizer feet	184
14.5. Tail lifts with hydraulic stabilizer feet C 750 L	185
14.6. Tail lifts with hydraulic stabilizer feet C 750 S.....	186
14.7. Standard tail lift with hydraulic underride protection	187
14.8. Retractable tail lift.....	188
14.9. Retractable tail lift R 750 L, R 750 SM, R 1000 SM, R 1500 SK and R 2000 LK	189
14.10. Retractable tail lift R 1500 L FLAT	190
14.11. Retractable tail lift R 1500 SH and R 2000 LH.....	191
14.12. Foldable tail lift.....	192
14.13. Ambulance models	193
15. Lubricants and equipment	194
16. Certificates in accordance with DIN EN 12642	195
17. Index	198

1. PALFINGER Tail Lifts – The tail lift

Congratulations on your purchase of a new tail lift from **PALFINGER Tail Lifts**!

With over 50 years' experience in the hydraulic tail lifts sector, **PALFINGER Tail Lifts** GmbH is one of the world's leading manufacturers of these extremely helpful loading systems these days.

You will find tail lifts from **PALFINGER Tail Lifts**, but also previous brands such as Hubfix, Interlift and Hayons Inter in more than 40 countries around the world these days. More than 100,000 tail lifts from the factory close to Bremen can be found on all 5 continents.

The unique service network of more than 2,500 service locations in Europe alone guarantees unlimited and optimised logistics.

Your new **PALFINGER Tail Lifts** tail lift has innovative and reliable technology. Our employees manufactured it very carefully. These are the best prerequisites for a long and fault-free service life.

In order to familiarise yourself with operation of your new tail lift, please read the following operating manual carefully. It also provides the required safety instructions for operating the tail lift.

If you still have any queries regarding your tail lift, please do not hesitate to contact the **PALFINGER Tail Lifts** service team.

2. About this manual

This manual contains important information on operating and maintaining the **PALFINGER Tail Lifts** tail lift safely and properly, as well as how to rectify simple faults independently.

Some texts in this manual have a special purpose and are marked as follows:

- Listing
- ▶ Instruction for action

- ▶ Read this manual completely, particularly the “Important safety information” chapter, before working with the lifting platform

2.1. Further documentation

- Assembly instructions (online)
- Spare parts catalogue (online: www.eetk.eu)
- Control Booklet
- Electrical circuit diagram
- Installation examination (on request)
- Short operating manual (optional)
- Supplement to the operating manual (optional)

2.2. Important safety information

The **PALFINGER Tail Lifts** tail lift is state-of-the-art and has been built according to the recognised safety engineering rules. Nevertheless, there is a danger of personal injury and material damage if you do not comply with the following general safety instructions and warnings before instructions in this manual.

- ▶ Therefore, read this manual thoroughly and completely before operating the tail lift.
- ▶ Keep the manual on hand so that it is accessible for all users at any time.
- ▶ If you sell or lend the vehicle with the tail lift, always include this manual.
- ▶ If you lose the operating manual or its condition deteriorates, request a new copy from the manufacturer.

2.3. Intended use

- ▶ Only use the tail lift to load and unload goods. Only the operator may ride along on the platform.
- ▶ Only operate the tail lift when it is installed on a vehicle. If you operate the tail lift without it being installed on a vehicle, there is a risk that the lifting cylinders will fall out if the lifting height is too high, resulting in personal injury and material damage.
- ▶ Comply with the performance limits specified in the technical data.
- ▶ Perform maintenance on the tail lift on a regular basis in accordance with the requirements in this operating manual.

Intended use also includes you having read and understood this operating manual, and particularly the “Important safety information” chapter.

Improper use includes if you

- Use the tail lift to lift objects other than the load that is on the platform.
- Allow people other than the operator to ride along on the platform (exception: ambulance).
- Operate the tail lift even though it is faulty.
- Use the tail lift for application areas that differ from those specified in this manual.
- Use the tail lift under operating conditions that differ from those specified in this manual.

2.4. Personnel qualifications

The tail lift may only be operated:

- By anyone who has read and understood this manual, particularly the "Important safety information" and "General operation" chapters.
- And who has familiarised themselves with operating and handling the tail lift.

2.5. Warnings in this manual

In this manual, safety instructions precede a procedure which incurs risks of personal injury or material damage.

Warnings are structured as follows:



Signal word!

Description of type and source of the danger

Description of consequences of non-observance

- ▶ Description of measures for avoiding danger

It is essential that the measures described to avert danger are complied with.

The signal word indicates the severity of the danger:

Signal word	Application
DANGER!	Indicates an imminent, major hazard that is certain to result in serious injury or even death if the hazard is not avoided.
WARNING!	Indicates a potential hazard that may result in serious injury or even death if the hazard is not avoided.
CAUTION!	Indicates a potentially hazardous situation which, if not avoided, may result in moderate or minor bodily injury or property damage.

2.6. You must observe the following

2.6.1. General information

- ▶ Always carry these instructions with you in the vehicle.
- ▶ Observe all applicable accident prevention regulations.

Note:

Structural modifications are only permitted with the manufacturer's approval. If modifications are made to the tail lift without our approval, all warranty claims are void. The manufacturer assumes no liability for damage, accidents, etc.

The same applies if using external spare parts if their use has not been approved explicitly by us.

2.6.2. When switching on

- ▶ Before switching the tail lift on every day, check whether all safety and warning equipment is available and functional.
 - Warning strips
 - Warning lights
 - Roll bar

2.6.3. During operation

- ▶ Ensure that the tail lift is unlocked before starting it up.
- ▶ Ensure that there is sufficient lighting in the loading area.
- ▶ Never carry people on the tail lift.
- ▶ Always load the tail lift so that the weight is distributed evenly.
- ▶ Secure the payload onto the tail lift so that it cannot fall off. Roller containers without brakes may only be transported using the tail lift if they have been secured using a roll bar to prevent them rolling away.
- ▶ Keep the movement area around the vehicle clear.
- ▶ Wear tight-fitting work clothing, non-slip safety shoes and protective gloves when operating the tail lift.

3. Supplied as standard

- Tail lift
- Sticker – ETMA instructions
- Large type plate (for the platform)
- Small type plate (for the lifting mechanism)
- Underride guard unit sign (UGU)
- Load diagram
- Operating manual
- Control Booklet
- Starter kit, comprising:
 - Underride guard unit certificate (on request)
 - Short operating manual
 - Large inspection sticker
 - Small inspection sticker

4. Model overview

A Standard tail lifts

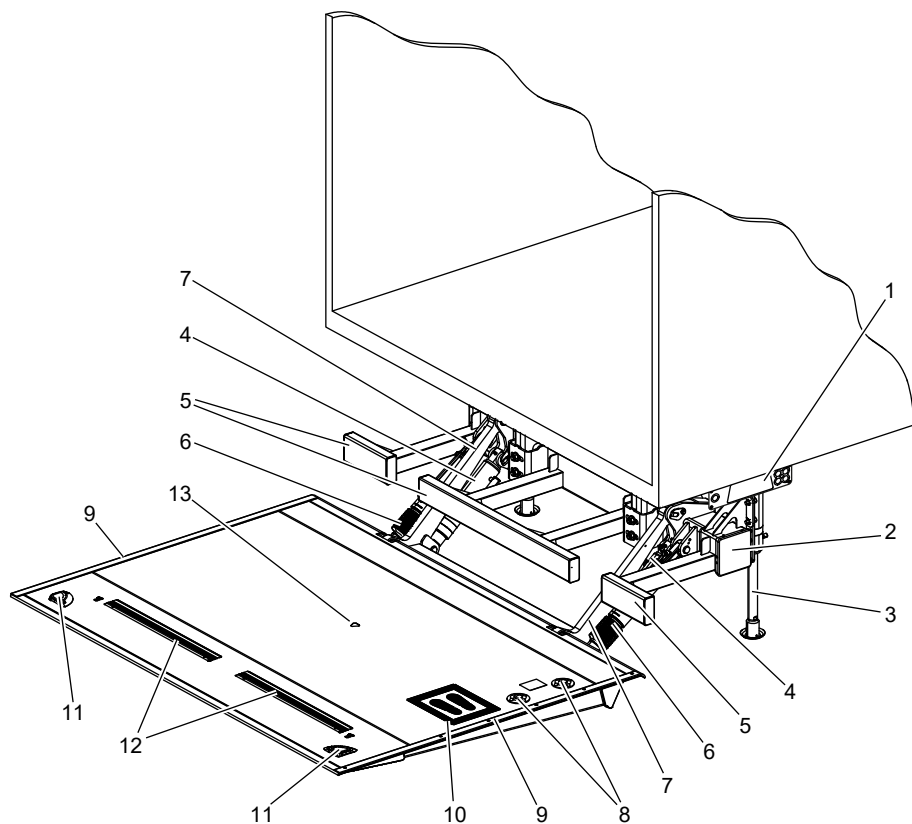

- | | | | |
|---|---|----|-------------------------------|
| 1 | Operating unit (Slimpanel) | 8 | Foot control |
| 2 | Hydraulic unit and controller (in stand tube) | 9 | SaveVis skirt lighting |
| 3 | Hydraulic prop | 10 | Footprint symbol |
| 4 | Lift cylinder | 11 | Warnfix warning light |
| 5 | Underride guard | 12 | Roll bar |
| 6 | Tilt cylinder | 13 | Useful load centre of gravity |
| 7 | Torsion frame, control rod | | |

C Standard tail lifts – van models

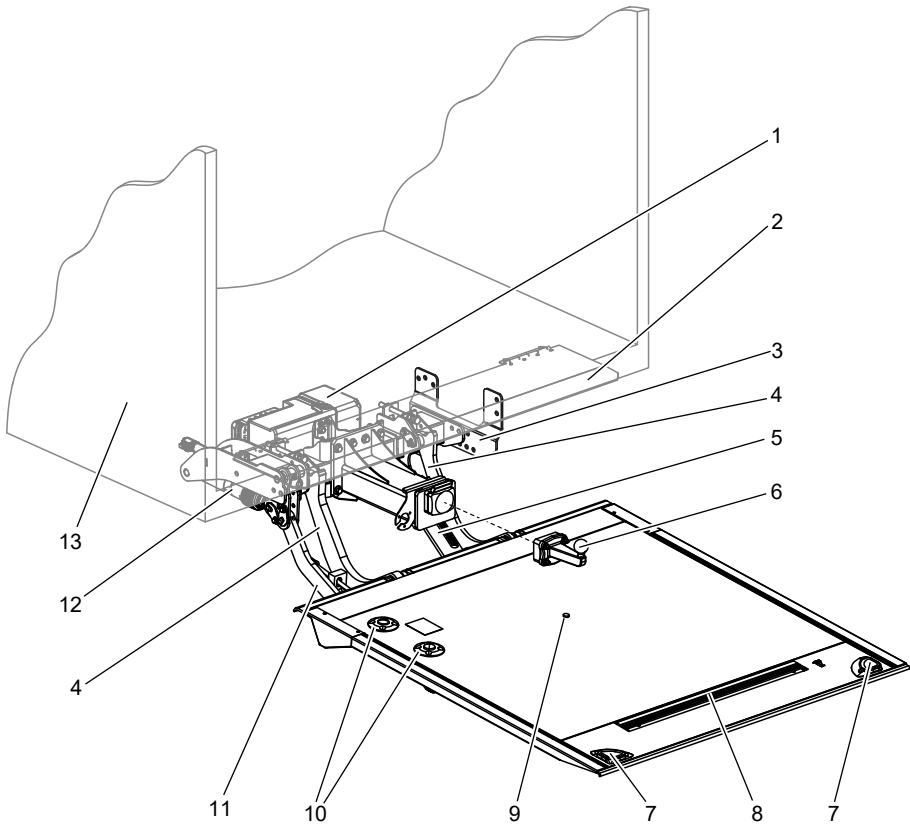

- | | | | |
|----------|--|-----------|-------------------------------|
| 1 | Hydraulic unit (reversible unit) | 8 | Roll bar |
| 2 | Bridging plate (optional) | 9 | Useful load centre of gravity |
| 3 | Installation plate (both sides, depending on vehicle type) | 10 | Foot control |
| 4 | Torsion frame, control rod | 11 | Parallel brace |
| 5 | Lift cylinder | 12 | Tilt cylinder |
| 6 | Ball head coupling, optional, removable | 13 | Slimpanel |
| 7 | Warnfix warning light | | |

F G Retractable tail lifts

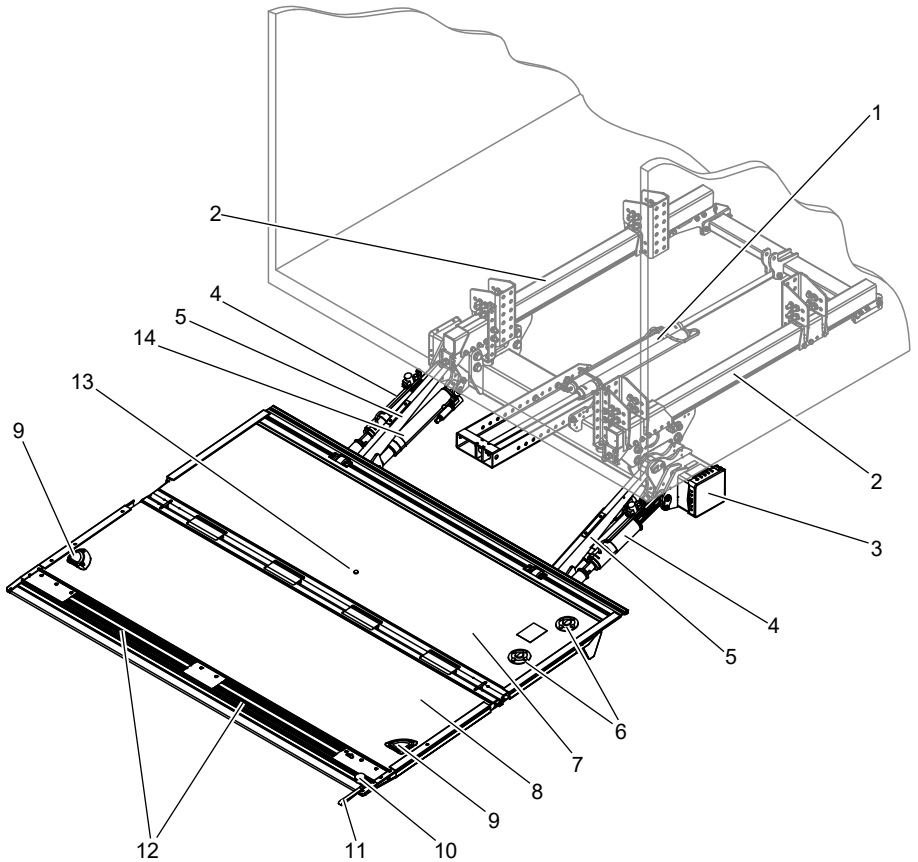

- | | | | |
|---|--|----|-------------------------------|
| 1 | Movement cylinder | 8 | Platform, moving part |
| 2 | Movement rail | 9 | Warnfix warning light |
| 3 | Hydraulic unit and controller
(in stand tube) | 10 | Rubber pad |
| 4 | Tilt cylinder | 11 | Handle |
| 5 | Torsion frame, control rod | 12 | Roll bar |
| 6 | Foot control | 13 | Useful load centre of gravity |
| 7 | Platform, fixed part | 14 | Lift cylinder |

Retraction mechanism

F

X

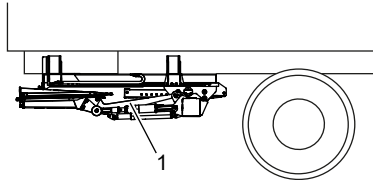

Y

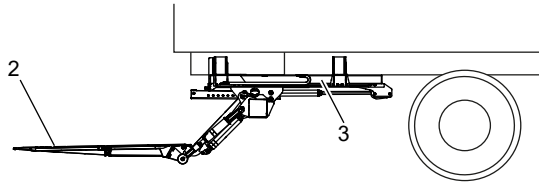

G

X

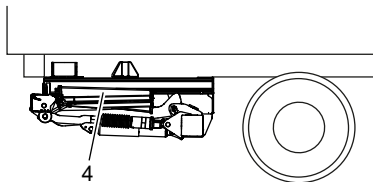

Y

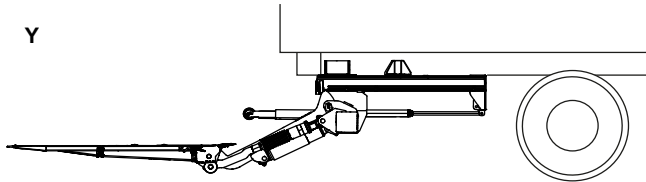

1 Torsion frame

3 Movement rail

2 Folding part of the platform

4 Platform package

X Transport position

Y Operating position

K L Foldable tail lifts

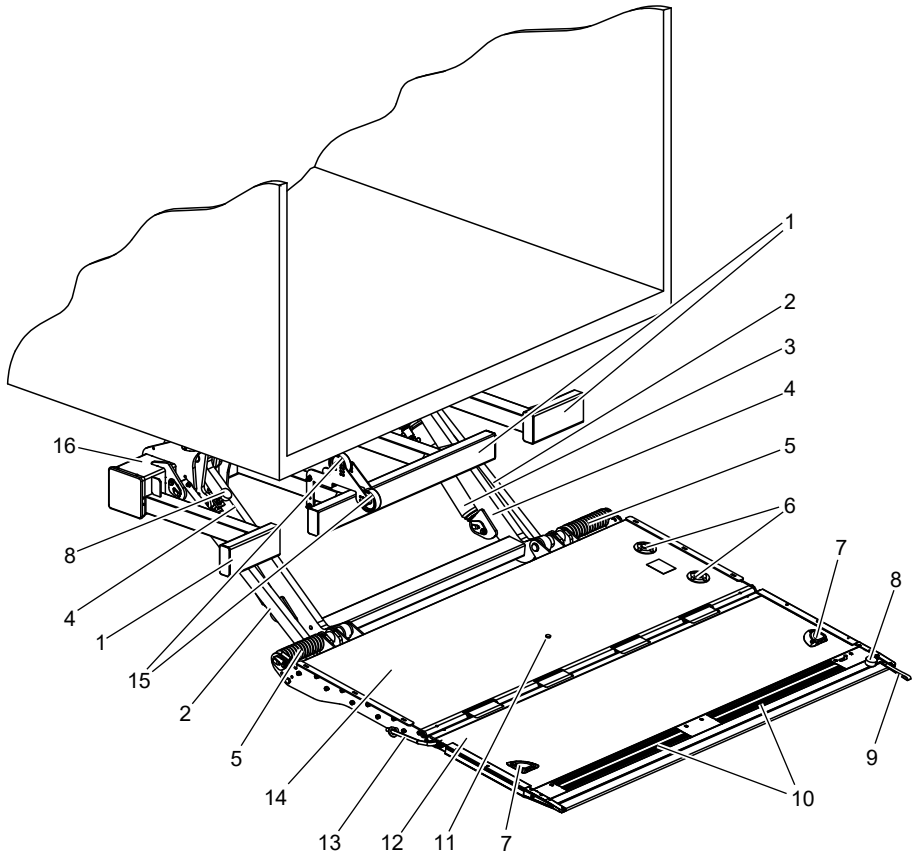

- | | | | |
|----------|----------------------------|-----------|-------------------------------|
| 1 | Underride guard | 9 | Handle |
| 2 | Parallel brace | 10 | Roll bar |
| 3 | Lift cylinder | 11 | Useful load centre of gravity |
| 4 | Torsion frame, control rod | 12 | Platform, moving part |
| 5 | Torsion spring | 13 | Torsion spring |
| 6 | Foot control | 14 | Platform, fixed part |
| 7 | Warnfix warning light | 15 | Roller |
| 8 | Rubber pad | 16 | Stand tube |

5. How to find your model

A letter (A to L) is assigned to every tail lift model in this operating manual. This is listed again at the start of every chapter that contains information regarding your tail lift model. The following overview shows which letter applies to your model.

5.1. Standard tail lifts

A Standard tail lifts

C 1000 S – C 3000 S

C 1000 LD – C 2500 L

C 1500 SZ – C 2500 SZ

C 2000 SK – C 2500 SK

C 750 SPLD SPRD – C 1000 SPL SPR

C 750 LD – C 1000 L / PTC 1000 LLW

C 1000 ML – C 1500 ML

C 1000 ML PRO – C 1500 ML PRO

C 750 S / PTC 750 S

C 500 LD – C 750 L / PTC 750 L / PTC 1000 LLW

C 750 SPL SPR

C 1500 LX – C 2000 LX

Operation: see page 53 to page 72.

C Standard tail lifts – van models

C 400 VAN – C 600 VAN

C 500 VAN FLEX, C 600 VAN FLEX

Operation: see page 55.

5.2. Retractable tail lifts

F Single-folding platform

R 1000 S – R 2500 S

R 1500 L – R 2500 L

R 1500 L FLAT

R 1500 SK – R 2000 LK

R 1500 S TRAIL – R 2500 L TRAIL

R 1500 S TRUCK – R 2000 L TRUCK

R 1000 S TRUCK LGD – R 2000 L TRUCK LGD

R 1500 S TRAIL LGD – R 2500 L TRAIL LGD

R 1000 S TRUCK CCD – R 2000 L TRUCK CCD

R 1500 S TRAIL CCD – R 2500 L TRAIL CCD

Operation: see page 73 to page 87.

G Double-folding platform

R 1500 SH – R 2000 LH

R 1500 SM – R 2000 LM

Operation: see page 89 to page 104.

5.3. Foldable tail lifts

K Four-cylinder model

F 1000 SH – F 1500 LH

F 1000 SX – F 1500 LX

Operation: see page 107 to page 111.

L Two-cylinder model

F 1000 LD – F 1500 LU

F 1000 L – F 1500 L

Operation: see page 113 to page 117.

5.4. Ambulance models

Ambulance

Ambulance models are standard tail lifts as described in “A”, chapter 5.1. They are also equipped with the option for hand pump operation (see the “Hand pump operation” chapter on page 133).

6. Pre-setting the tail lift

This chapter provides you with basic settings that enable convenient and safe use.

ACF 6.1. Adjusting the ground alignment time

The factory can only define the time at which the platform changes over to tilting mode (ground alignment) after being set down on the ground on E systems with tilt switch B13.

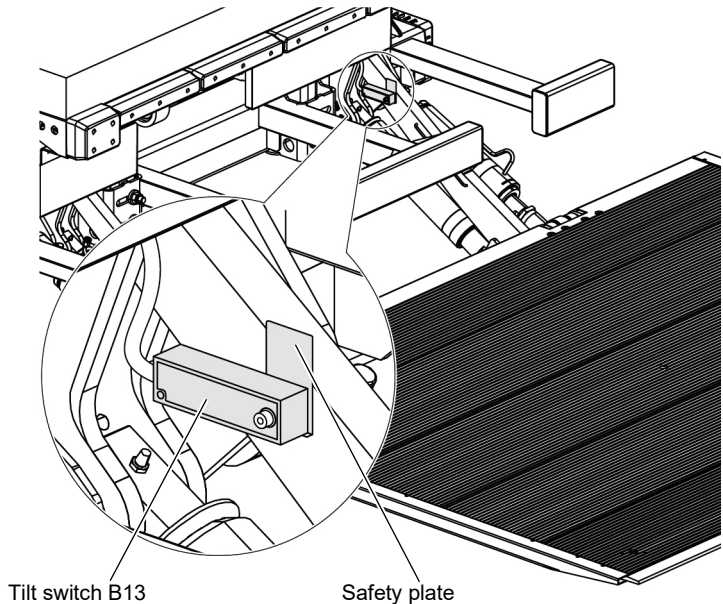

In order to adjust the ground alignment time:

- ▶ Move the platform to the horizontal position, approx. 250 mm above the floor.
- ▶ Loosen the fixing bolt on tilt switch B13.
- ▶ Adjust tilt switch B13 so that it is exactly horizontal.

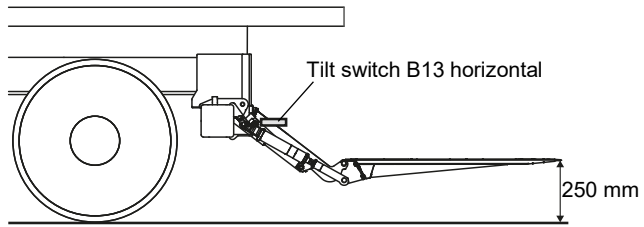

Earlier ground alignment:

- ▶ In order to have ground alignment performed “earlier”, turn tilt switch B13 clockwise by a few millimetres.

Later ground alignment:

- ▶ In order to have ground alignment performed “later”, turn tilt switch B13 anticlockwise by a few millimetres.
- ▶ Retighten the fastening screw on tilt switch B13.
- ▶ Check whether the platform now starts the tilting procedure at the time you require.
- ▶ Check whether the spring ring is also installed between the tilt switch and the screw, and fold the safety plate back.

The time at which the platform should tilt has now been set. The platform tilts earlier or later accordingly.

AFGK 6.2. Pre-setting the platform tilt

After the platform has raised off the ground, it returns to the position you set. You therefore have the option of setting the platform tilt higher or lower individually.

- ▶ Use the “Open/Close” button on the control panel to adjust the required top position (see “Operation” from page 52). This is only possible if there is a B15 tilt sensor on the platform.

A C F G K L **6.3. Adjusting tilt sensor B15S**

The new tilt sensor B15S is used to measure the platform tilt and is no longer mechanically adjustable. This sensor can be adjusted using the controller.

Note:

Changes to the tilt sensor's parameters, e.g. for stopping when in the horizontal position, are not considered standardised use of the tail lift. Subsequent adjustments to this sensor are therefore at the owner's own risk.

DANGER!**Danger to life and material damage in case of improper adjustment of tilt sensor B15S!**

If tilt sensor B15S is adjusted to too steep a platform tilt, the load may roll off the platform. There is a risk of serious or fatal injury to persons on the platform. Material damage may occur.

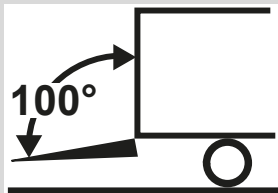

- ▶ Adjust tilt sensor B15S so that the platform tilt is 100 degrees or less.

**To perform adjustment and set a correction value:**

- ▶ Open the platform (see the "Operation" chapter from page 52).
- ▶ Press one of the foot controls eight times.

If there is no foot control available:

- ▶ Give a plus pulse eight times to plug location J3, pin 6, on the board.

The 7-segment display on the board indicates "J" for adjustment. The warning lights on the platform illuminate continuously. The current angle of the platform was taken as the reference value.

- ▶ From this platform position, move to the desired correction angle.
- ▶ Press one of the foot controls eight times.

If there is no foot control available:

- ▶ Give a plus pulse eight times to plug location J3, pin 6, on the board.

The 7-segment display on the board indicates “0” or “1”. The warning lights on the platform flash again. The new inclination of the platform is stored as a correction value.

To remove the correction value again or set it to zero degrees:

- ▶ Press one of the foot controls eight times.

If there is no foot control available:

- ▶ Give a plus pulse eight times to plug location J3, pin 6, on the board.

The 7-segment display indicates “J” for adjustment. The warning lights on the platform illuminate continuously.

- ▶ Disconnect the 3-pin plug for platform sensor J41C from the board.
- ▶ Press one of the foot controls eight times.

If there is no foot control available:

- ▶ Give a plus pulse eight times to plug location J3, pin 6, on the board.

The 7-segment display on the board indicates “5”. The warning lights on the board flash again.

- ▶ Plug connector J41C back in.

The 7-segment display on the board indicates “0” or “1”. The correction value has been deleted.

A 6.4. Adjusting the pressure switch on the hydraulic stabilizer feet

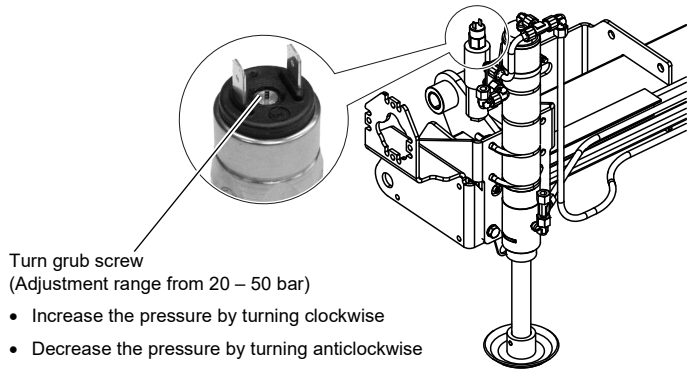

If the hydraulic stabilizer feet raise the vehicle too high or the props do not reach the ground, the pressure switch of the stabilizer feet can be adjusted.

The grub screw on the pressure switch must be turned for this purpose.

- ▶ To decrease the contact pressure of the props, turn the grub screw anti-clockwise one rotation.
- ▶ To increase the contact pressure of the props, turn the grub screw clockwise one rotation.
- ▶ After adjusting the contact pressure, check the adjustment by lowering the props. If the desired shut-off of the stabilizer feet is not provided, repeat the adjustment.

F 6.5. Calibrating the controller

- ▶ Perform the complete working cycle (lowering, extending, lowering, unfolding, raising, lowering, folding on, raising, retracting and raising) once on retractable tail lifts LGD and CCD during commissioning.

The controller calibrates itself due to this. This is required to operate the tail lift without faults.

If performing the working cycle fails during commissioning:

- ▶ Move the tail lift into the fully retracted transport position.
- ▶ Disconnect and reconnect the operating voltage.

Perform the working cycle again.

G 6.6. Adjusting the BDF position

On vehicles with a BDF swap body system, different lengths of attachments or containers can be loaded. To ensure that the platform approaches the correct position on the loading edge for attachments or containers of the same length, the BDF position can be adjusted on retractable tail lifts.

To adjust the BDF position:

- ▶ Extend the platform completely, lower it and unfold the platform (see the “Operation” chapter from page 89).

The proximity switches on the tail lift are now below the contact plates for the completely extended position.

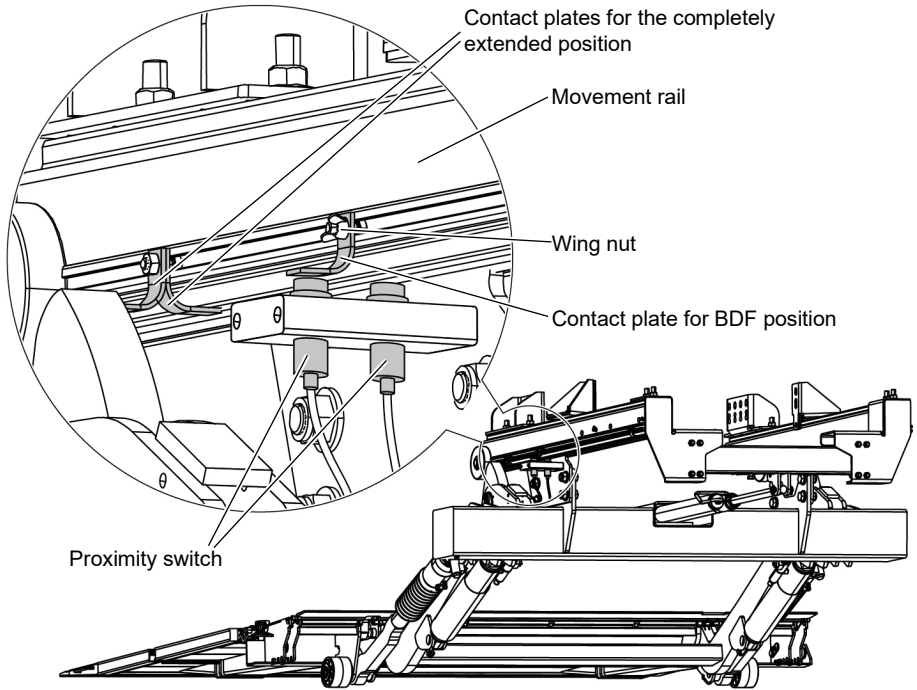

- ▶ Move the platform to the same height as the vehicle bed.
- ▶ Move the platform towards the vehicle until it touches the structure.
- ▶ Check the alignment to the bed and re-adjust if necessary.
- ▶ Loosen the wing nuts on the contact plate for the BDF position (see the illustration above).
- ▶ Move the contact plate on the movement rail until it is above the outer proximity switch.
- ▶ Re-tighten the wing nut.

The BDF position is adjusted.

6.7. Programming the button code on the Slimpanel

Note:

Tail lifts that are switched on and off using the button code on the Slimpanel are always switched on until a button code is programmed and the tail lift is therefore switched off.

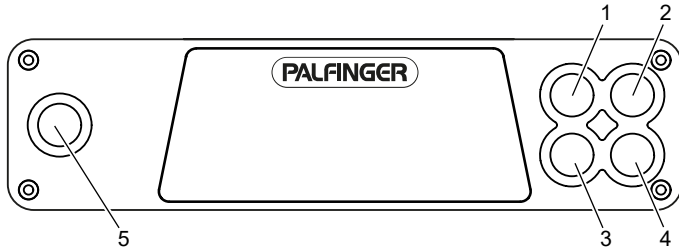

- 1 Function pushbutton 1
- 2 Function pushbutton 2
- 3 Function pushbutton 3
- 4 Function pushbutton 4
- 5 Additional pushbutton

To enter the button code:

- ▶ Lower the platform to the ground.
- ▶ Press and hold the additional pushbutton **(5)** and all function pushbuttons **(1 to 4)** for five seconds.

The warning lights on the platform illuminate continuously.

- ▶ Press the function pushbutton **(1)**.
- ▶ Then press four of the function pushbuttons **(1 to 4)** in any sequence and composition.

The sequence of five button presses entered in this way is the defined button code. As soon as you have pressed the fifth button, the button code has been entered. The warning lights on the platform flash again.

If you have forgotten the button code:

- ▶ Pull plug J11 out on the board for at least one second and plug it back in.
- ▶ Enter the button code again.

7. General operation

This chapter contains basic information about what you must note during operation. This information relates to the all tail lift models.

- ▶ Read the entire chapter carefully and pay particular attention to the following warning notices.

Note:

Risk of battery discharge!



If the adjacent logo is shown on your tail lift's controller, your tail lift is equipped with a battery monitoring system (BMS).

If the battery capacity reduces to below the limit value, a horn sounds and the tail lift is switched off automatically to protect the battery. The battery voltage is now so low that only one single engine start is possible. If you continue to use the tail lift, you can no longer start the vehicle!

- ▶ Start the vehicle engine as soon as the horn sounds in order to charge the battery!

Note:

For information regarding the recommended battery capacity, see the corresponding table on page 173.

7.1. Switching the tail lift on

CAUTION!

Risk of injury or damage to property due to insufficient securing!

People can be injured and your vehicle, the tail lift or other vehicles can be damaged if you do not observe the following:



- ▶ Before starting work, ensure that all safety and warning equipment is available and functional.
- ▶ Only stop in locations permitted by the Highway Code.
- ▶ Secure the vehicle to prevent it rolling away, e.g. using the handbrake, putting it in gear or using chocks.
- ▶ Cordon off the vehicle area with warning flags and warning lights before loading or unloading your vehicle.

There are four options for switching the tail lift on depending on the model:

- Control unit with rocker switch in the driver's cab
- Key switch on the side controller or the Slimpanel
- Button code on the Slimpanel
- Battery main switch

Control unit with rocker switch

To use the control unit to switch the tail lift on:

- ▶ Actuate the rocker switch on the control unit.

The tail lift is switched on. The light in the rocker switch illuminates red.

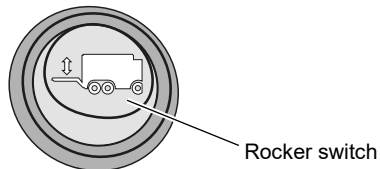

Key switch

To use the key switch on the side controller or the Slimpanel to switch the tail lift on:

- ▶ Insert the key into the keyhole on the key switch and turn clockwise. The tail lift is switched on. The indicator lamp in the driver's cab illuminates red.

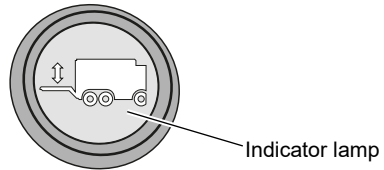

Button code on the Slimpanel

To use the button code on the Slimpanel to switch the tail lift on:

- ▶ Use the auxiliary and function pushbuttons on the Slimpanel to enter the button code (see "Programming the button code on the Slimpanel" from page 32).

The tail lift is switched on. The indicator lamp in the driver's cab illuminates red.

Battery main switch

To use the battery main switch to switch the tail lift on:

- ▶ Turn the battery main switch clockwise until the pin engages.

The tail lift is switched on. The indicator lamp in the driver's cab illuminates red.

Driver's cab controller with camera system

If a driver's cab controller with camera system is present, observe the supplement to the operating manual, which is enclosed with the driver's cab controller as a separate document.

7.2. Extending the stabilizer feet on your vehicle

CAUTION!

Vehicle damage!

The vehicle can be damaged if the ground does not have sufficient load bearing capacity or if the hydraulic stabilizer feet are adjusted incorrectly.



- ▶ Ensure that the ground's load bearing capacity is sufficient for the stabilizer feet!
- ▶ Never use the hydraulic stabilizer feet to lift the vehicle!
- ▶ Re-adjust the stabilizer feet several times when loading the vehicle.

CAUTION!

Risk of injury or damage to property on vehicles with air suspension

If you do not block your vehicle's air suspension, the axles will be unloaded completely and the weight will be transferred to the stabilizer feet. This could cause people to be injured and damage to the tail lift, your vehicle or the load.



- ▶ Move the air suspension control lever on your vehicle to the "Block" position!

Mechanical stabilizer feet

To extend the mechanical stabilizer feet:

- ▶ Loosen the clamping device.
- ▶ Lower the stabilizer feet to the ground.
- ▶ Re-tighten the clamping unit.

Hydraulic stabilizer feet

- ▶ To extend the hydraulic stabilizer feet, see "Operation via the two hand control and hydraulic stabilizer feet" from page 59.

7.3. Retracting the stabilizer feet on your vehicle

Mechanical stabilizer feet

- ▶ Loosen the clamping device.
- ▶ Push the stabilizer feet up into the transport position.
- ▶ Re-tighten the clamping unit.

Hydraulic stabilizer feet



CAUTION!

Risk of frame damage!

On vehicles with air suspension, the weight may be transferred completely to the stabilizer feet.

- ▶ Before retracting the stabilizer feet, use the air suspension to raise the vehicle so that the stabilizer feet are relieved.
- ▶ To retract the hydraulic stabilizer feet, see “Operation via the two hand control and hydraulic stabilizer feet” from page 59.

7.4. Moving the platform

WARNING!

Risk of injury or damage to property due to moving the platform!

People can be injured when the platform moves automatically. Vehicles and other objects in the movement range may be damaged. The payload can fall off and get damaged or injure people.



- ▶ Ensure that there is sufficient space for the tail lift behind the vehicle.
- ▶ Ensure that you can view the entire working range and that nobody remains close to the platform.
- ▶ Keep people clear of the movement range while you are moving the platform.
- ▶ Observe the payload, the movement range and the crushing point to the vehicle while you are moving the platform.
- ▶ Only adjust the platform tilt when it is not loaded.

WARNING!

Risk of injury due to not holding on properly or too little space on the platform!

People may fall off the platform and get injured.



- ▶ Leave enough space for the operator (at least 50 x 60 cm) when loading the platform.
- ▶ Only people who are operating the tail lift are permitted to ride on the platform.
- ▶ Never hold the payload. Always hold onto the handle or the railing!
- ▶ Observe the payload and the movement range while you are moving the platform.

The way in which you move the platform depends on your model and the corresponding side control. The relevant instructions are provided in the “Operation” chapter from page 52.

7.4.1. Definitions of terms

You are able to do the following to the platform:

Open



The platform opens and moves out of the vertical transport position into the operating position that you require. This position is saved and moved to again when lifting after ground alignment.

Close



The platform closes and moves out of the horizontal operating position into the vertical transport position.

Extend

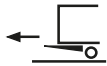

The platform extends below the vehicle.

Retract

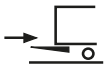

The platform moves under the vehicle.

Unfold



The platform unfolds from the transport position into the operating position.

Fold



The platform folds out of the operating position into the transport position.

Lower



The platform moves downwards in the horizontal position.

Lift

The platform moves upwards in the horizontal position.

Ground alignment

After lowering, the platform moves out of the operating position and touches the ground.

The folding two-cylinder models tilt gradually while lowering.

Horizontal positioning

Before the platform lifts off the ground, it tilts into the horizontal operating position that was saved when opening.

The folding two-cylinder models tilt gradually into the horizontal operating position while raising.

Adjusting the platform tilt

The platform tilts at a greater or smaller angle into the operating position that you require

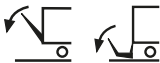
7.4.2. Opening/unfolding/extending the platform and adjusting the platform tilt

► Depending on the model, use the side control, the manual hand cable control or the radio remote control to open, unfold or extend the tail lift (see the “Operation” chapter from page 52).

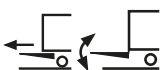

► Depending on the model, turn the rotary switch to open or close the platform as described in the “Operation” chapter from page 52 until the unloaded platform has reached the tilt that you require.

7.4.3. Lowering the platform

The platform remains in the horizontal position while being lowered. After the platform has been set down on the ground, the platform tilts until the platform edge is resting on the ground.

► Depending on the model, use the side control, the foot control, the hand cable control or the radio remote control to lower the platform (see the “Operation” chapter from page 52).

The platform lowers slowly and aligns with the ground automatically.

7.4.4. Lifting the platform



The platform tilts into the horizontal position before lifting. The platform remains in the horizontal position while being lifted.

- ▶ Depending on the model, use the side control, the foot control, the hand cable control or the radio remote control to lift the platform (see the “Operation” chapter from page 52).

7.4.5. Closing/folding in/retracting the platform

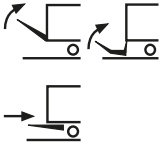

- ▶ Depending on the model, use the side control, the manual hand cable control or the radio remote control to close, fold or retract the platform (see the “Operation” chapter from page 52).

7.5. Operating the platform lock

The tail lift is delivered with an additional mechanical platform lock on request.

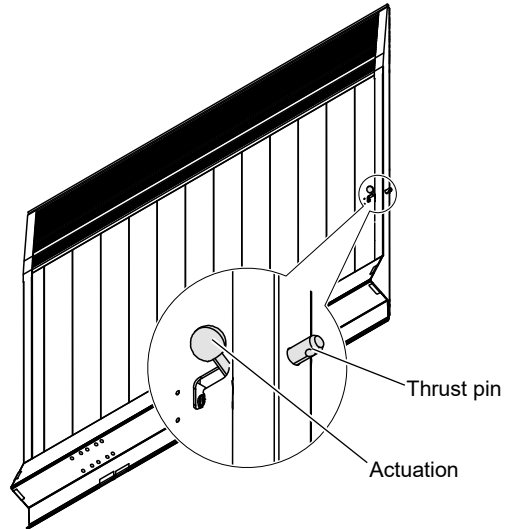

- ▶ Open the platform lock before operating the tail lift.
- ▶ Close the platform lock before starting to drive.

7.6. Setting up and taking down the platform railing

Your tail lift's platform is secured with railings depending on the model. There are two basic types of railing possible:

- P railing
- A railing

Proceed as following to set up or take down the railings on the platform:

Setting up the P railing

- ▶ Swing the relevant railing up by 90° until it engages.

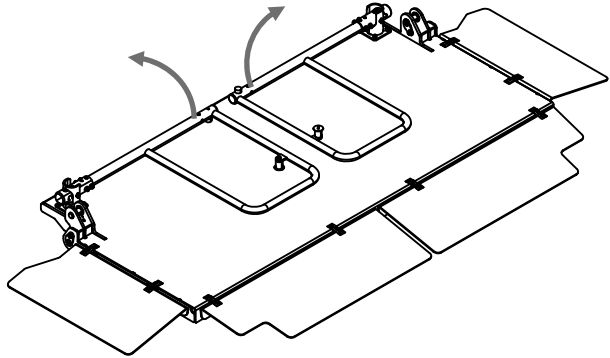

Taking down the P railing

- ▶ Pull the relevant railing up to unlock (1)
- ▶ Swing the relevant railing inwards (2) until the magnetic buffer is resting on the platform.

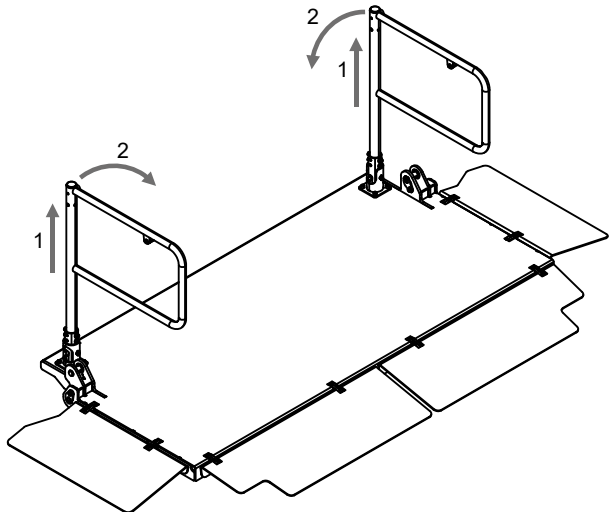

Setting up the A railing

- ▶ Pull the relevant railing to the centre of the platform for a short time (1)
- ▶ Swing the relevant railing up by 90° (2) and lower it until it engages.

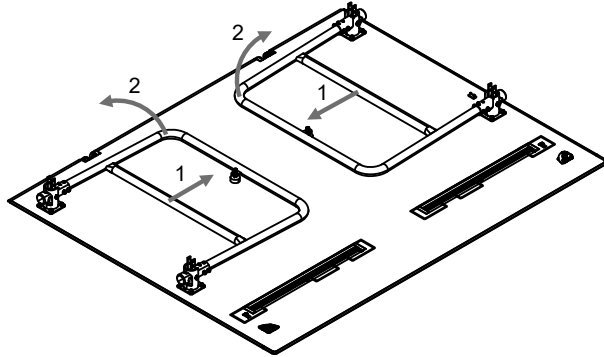

Taking down the A railing

- ▶ Pull the relevant railing up (1).
- ▶ Then swing the relevant railing inwards (2) until the magnetic buffer is resting on the platform.

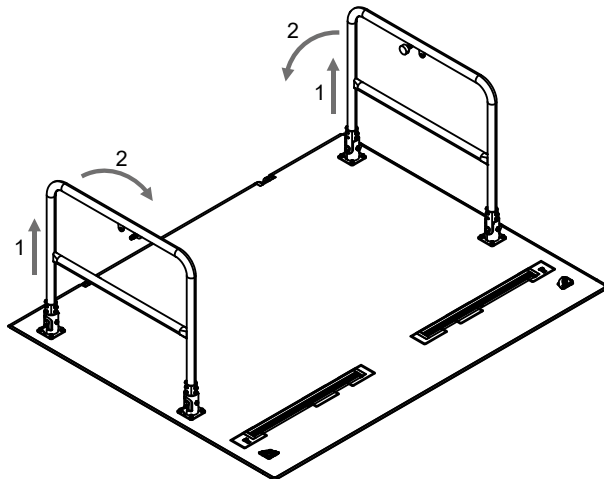

7.7. Roll stop

There are optional roll stops on the outside of the platforms as roll bars. The roll stops are operated using a knurled wheel or a bolt. Self-erecting roll stops are operated using a lever.

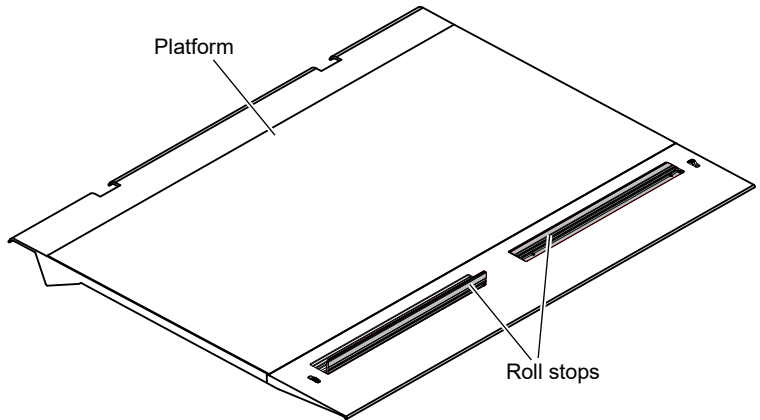

7.7.1. Operation via the knurled wheel

- ▶ Use your foot to actuate the knurled wheel next to the roll stop in order to fold the roll stop up.

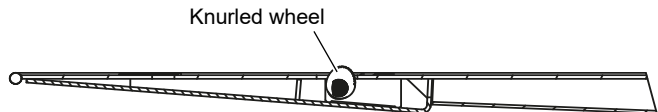

- ▶ Step on the roll stop to fold it down.

7.7.2. Operation via the bolt

- ▶ Use your foot to actuate the bolt next to the roll stop in order to fold the roll stop up.

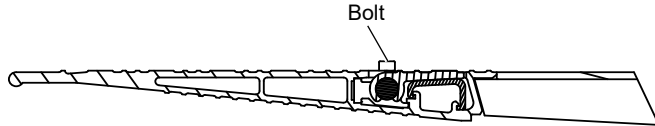

- ▶ Step on the roll stop to fold it down.

7.7.3. Operating a self-erecting roll stop

If a self-erecting roll stop is folded up, it can be driven over from the outside, e.g. using a lift truck. It folds down when doing so and then folds up again. The lift truck then runs against the roll stop that is folded up from the vehicle side.

To fold the roll stop up:

- ▶ Use your foot to move the lever next to the roll stop.

The roll stop folds up.

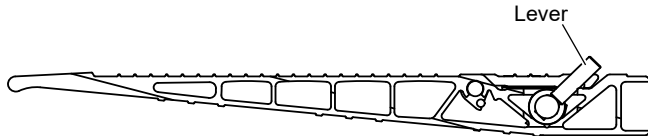

To fold the roll stop down:

- ▶ Use your foot to move the lever next to the roll stop back.
- ▶ Use your foot to press the roll stop down until it engages.

7.8. Loading or unloading the platform

WARNING!

Uncontrolled load movements due to vehicle movements!



If you load the tail lift with a heavy load from the freight space, the vehicle and the tail lift may tilt. The load on the tail lift may move out of control. Risk of injury and material damage are the consequence.

- ▶ Ensure that the vehicle's minimum front axle load is always met.
- ▶ Ensure that the maximum rear axle load is not exceeded.

WARNING!

Damage to the platform due to driving on it using a forklift!



The platform is not suitable to be driven on using a forklift. If you drive a forklift onto the platform, damage resulting in injuries and damage to property may occur.

- ▶ Never drive a forklift onto the platform.

CAUTION!

Damage to the tail lift due to incorrect loading!

The tail lift may get damaged if you load the platform excessively or unevenly.



- ▶ Do not load more than the weight specified in the "Load diagrams" chapter from page 174. Also consider the weight of people being carried along. The load table is also provided on the side control.
- ▶ Load the platform in the centre. The payload centre of gravity should be as close to the vehicle as possible. If you load the platform on one side, the payload weight must not exceed 50% of the permissible payload.
- ▶ Only load rolling containers without brakes if a roll bar (roll stops or roller bumps) is present. Always use this roll bar to secure rolling containers without brakes.

7.8.1. Loading or unloading the platform on the ground

- ▶ Roll or lift the payload onto the platform.
- ▶ Use attached braking devices or the roll bar to secure the rolling containers onto the platform.

7.8.2. Loading or unloading the platform on a ramp

CAUTION!

Risk of falling when unloading on a ramp!

If there is an edge between the ramp and platform when loading or unloading the vehicle on a ramp, people can fall.

- ▶ Lower the platform manually when unloading and the corresponding vehicle suspension.



You have two options for loading your vehicle on a ramp:

- You can use a separate loading ramp. Ensure that there is sufficient space for the tail lift under the ramp.

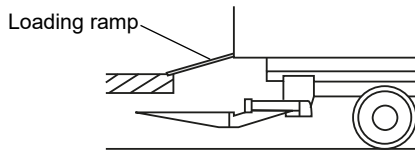

- You can use the tail lift itself as a loading ramp on a ramp. Ensure that the platform edge extends at least 150 mm over the ramp.

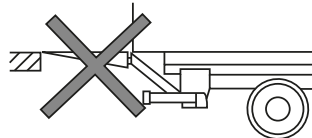
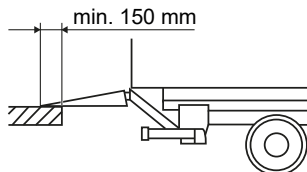

Note:

The maximum load must not be exceeded.

The tail lifts are equipped with a float position. The float position is a safety-related function. If the vehicle lowers during loading, this ensures that the platform subsides automatically.

The float position does not work when unloading. You must lower the platform yourself. This is how to prevent a trip hazard forming on the end of the platform.

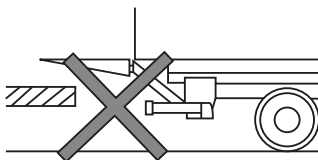

7.9. Switching the tail lift off

DANGER!

Dangers due to a platform that is not closed or folded in completely!



If the platform opens during the journey, is partially open or not folded in completely, it sticks out into flowing traffic. People may get seriously injured. Material damage may occur.

- ▶ Ensure that the platform is in the closed or folded in transport position.
- ▶ Ensure that the light in the rocker switch / the indicator lamp in the driver's cab is extinguished.
- ▶ Only start driving once this is the case.

WARNING!

Risk of injury or damage to property due to unauthorised use!



If unauthorised people operate the tail lift, this results in a risk of injuries and damage to property.

- ▶ Switch the tail lift off.
- ▶ Only leave the vehicle once this has been done.

Note:

The light in the rocker switch / the indicator lamp only extinguishes once the platform has been closed completely. Check the platform position of the light/indicator lamp does not extinguish when switching off.

Exception: When using the battery main switch to switch the tail lift off, the light/indicator lamp also extinguishes.

There are various options for switching the tail lift off depending on the model:

- Control unit with rocker switch in the driver's cab
- Key switch on the side controller or the Slimpanel
- Button code on the Slimpanel
- Battery main switch

Control unit with rocker switch

To use the control unit to switch the tail lift off:

- ▶ Actuate the rocker switch on the control unit (see the illustration on page 34).

The tail lift is switched off. The light in the rocker switch extinguishes.

Key switch

To use the key switch on the side controller or the Slimpanel to switch the tail lift off:

- ▶ Insert the key into the keyhole on the key switch and turn anticlockwise.
- ▶ Remove the key.

The tail lift is switched off. The indicator lamp extinguishes (see the illustration on page 35).

Button code on the Slimpanel

To use the button code on the Slimpanel to switch the tail lift off:

- ▶ Use the auxiliary and function pushbuttons on the Slimpanel to enter the button code (see “Programming the button code on the Slimpanel” from page 32).

The tail lift is switched off. The indicator lamp extinguishes (see the illustration on page 35).

Battery main switch

To use the battery main switch to switch the tail lift off:

- ▶ Turn the battery main switch anticlockwise until the pin engages.

The tail lift is switched off. The indicator lamp extinguishes (see the illustration on page 35).

8. Operation

This chapter describes the controls for the various tail lift models. To identify your model, see “How to find your model”, page 22.

You have several options for operating the tail lift:

- Using the side control or the Slimpanel (depending on the model, see chapter 8.1),
- Using the foot control (optional, see chapter 8.2, page 119),
- Using the hand cable control or the radio remote control (optional, see chapter 8.3, page 121) or
- Using the special operating elements (optional, see page 127 to page 132).

Note:

This manual describes the standard program. Special programs deviate from this description or have further functions. Our customer service department will provide you with a comprehensive description of your type.

8.1. Side control

Depending on your tail lift model, information regarding operating the side controls is provided on:

A	Standard tail lifts	Page 53 to page 72
C	Standard tail lifts – van models	Page 55
F	Retractable tail lifts Single-folding platform	Page 73 to page 87
G	Retractable tail lifts Double-folding platform	Page 89 to page 104
K	Foldable tail lifts, four-cylinder models	Page 107 to page 111
L	Foldable tail lifts, two-cylinder models	Page 113 to page 117

A 8.1.1. Operation via the two hand control

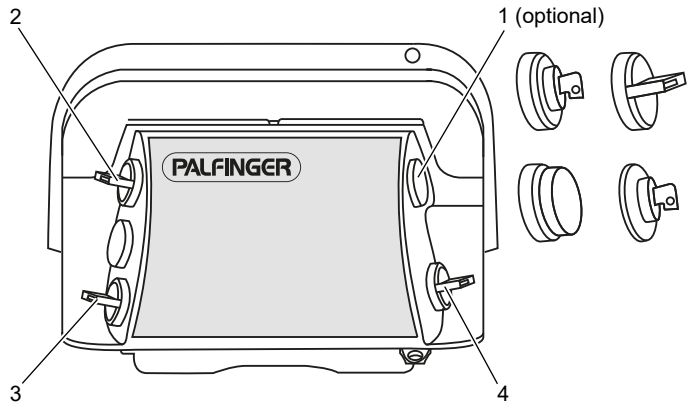

- 1 optional: Key switch, rotary switch, emergency stop button, E30 key
- 2 Rotary switch: Open/Close
- 3 Rotary switch: Lift/lower
- 4 Rotary switch: Additional switch

DANGER!

Risk of accidents and injuries!

When operating the tail lift, personal injury and damage to property may occur if you do not follow the instructions in the “General operation” chapter.

- ▶ First read the “General operation” chapter from page 33 before operating your tail lift.



Opening the platform



- ▶ Turn the rotary switches **(2)** and **(4)** downwards simultaneously and hold both until the platform is in the horizontal operating position.

If optional load securing is present, the platform first lowers slightly and then folds into the horizontal operating position.

Lowering the platform



- ▶ Turn the rotary switches **(3)** and **(4)** downwards simultaneously and hold both in this position until the platform has been set down on the ground.

After the platform has been set down on the ground, it tilts and aligns with the ground.

Lifting the platform



- ▶ Turn the rotary switches **(3)** and **(4)** upwards simultaneously and hold both in this position until the platform has reached the vehicle bed.

The platform first tilts into the horizontal or preset position before lifting.

Closing the platform



- ▶ Turn the rotary switches **(2)** and **(4)** upwards simultaneously and hold both in this position until the platform has closed.

If optional load securing is present, the platform first only closes to around 80° and lowers slightly. It then moves into the vertical transport position and lifts into the load securing device.

A C 8.1.2. Operation via the Slimpanel

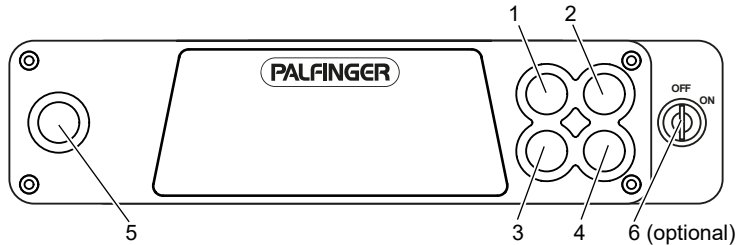

- 1 Function pushbutton 1
- 2 Function pushbutton 2
- 3 Function pushbutton 3
- 4 Function pushbutton 4
- 5 Additional pushbutton
- 6 optional: Key switch

DANGER!

Risk of accidents and injuries!



When operating the tail lift, personal injury and damage to property may occur if you do not follow the instructions in the “General operation” chapter.

- ▶ First read the “General operation” chapter from page 33 before operating your tail lift.

Opening the platform



- ▶ Press and hold the additional pushbutton **(5)** and the function pushbutton **(4)** until the platform is in the horizontal operating position.

If optional load securing is present, the platform first lowers slightly and then folds into the horizontal operating position.

Lowering the platform



- ▶ Press and hold the additional pushbutton **(5)** and the function pushbutton **(3)** until the platform aligns with the ground.

After the platform has been set down on the ground, it tilts and aligns with the ground.

Lifting the platform



- ▶ Press and hold the additional pushbutton **(5)** and the function pushbutton **(1)** until the platform has reached the vehicle bed.

The platform first tilts into the horizontal or preset position before lifting.

Closing the platform



- ▶ Press and hold the additional pushbutton **(5)** and the function pushbutton **(2)** until the platform is closed.

If optional load securing is present, the platform first only closes to around 80° and lowers slightly. It then moves into the vertical transport position and lifts into the load securing device.

A 8.1.3. Operation via the two hand control without automatic ground alignment

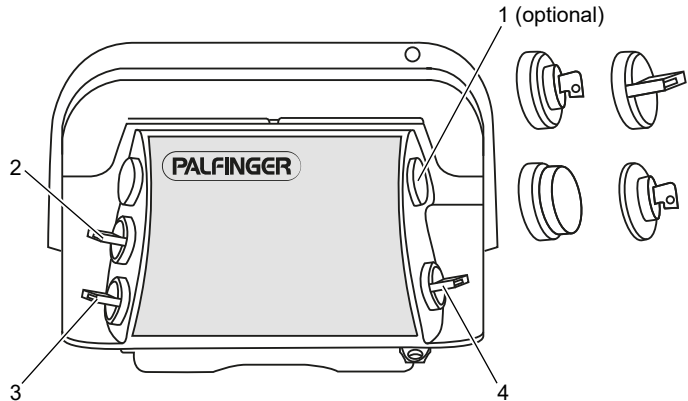

- 1 optional: Key switch, rotary switch, emergency stop button, E30 key
- 2 Rotary switch: Open/Close
- 3 Rotary switch: Lift/lower
- 4 Rotary switch: Additional switch



DANGER!

Risk of accidents and injuries!

When operating the tail lift, personal injury and damage to property may occur if you do not follow the instructions in the “General operation” chapter.

- ▶ First read the “General operation” chapter from page 33 before operating your tail lift.

Opening the platform



- ▶ Turn the rotary switches **(2)** and **(4)** downwards simultaneously and hold both until the platform is in the horizontal operating position.

Lowering the platform



- ▶ Turn the rotary switches **(3)** and **(4)** downwards simultaneously and hold both in this position until the platform has reached the ground.

Ground alignment



After the platform has been set down on the ground:

- ▶ Turn the rotary switches **(2)** and **(4)** downwards simultaneously.
The platform tilts and aligns with the ground.

Horizontal positioning



- ▶ Turn the rotary switches **(2)** and **(4)** upwards simultaneously and hold both until the platform is in the horizontal position.

Lifting the platform



- ▶ Turn the rotary switches **(3)** and **(4)** upwards simultaneously and hold both in this position until the platform has reached the vehicle bed.

Closing the platform



- ▶ Turn the rotary switches **(2)** and **(4)** upwards simultaneously and hold both in this position until the platform has closed.

The platform moves into the vertical transport position.

A 8.1.4. Operation via the two hand control and hydraulic stabilizer feet

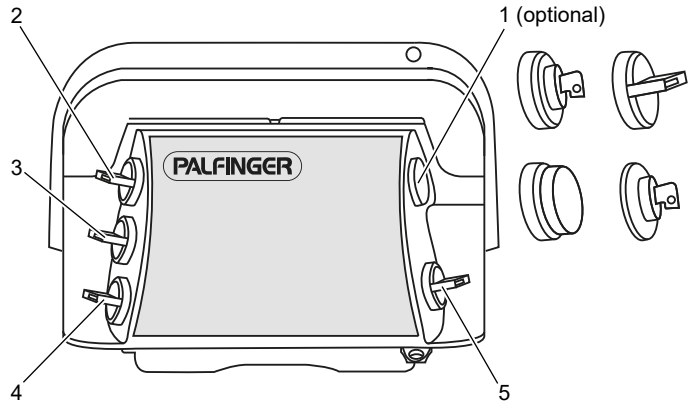

- 1 optional: Key switch, rotary switch, emergency stop button, E30 key
- 2 Rotary switch: Open/Close
- 3 Rotary switch: Retracting and extending
- 4 Rotary switch: Lift/lower
- 5 Rotary switch: Additional switch



DANGER!

Risk of accidents and injuries!

When operating the tail lift, personal injury and damage to property may occur if you do not follow the instructions in the “General operation” chapter.

- ▶ First read the “General operation” chapter from page 33 before operating your tail lift.

Extending the hydraulic stabilizer feet

- ▶ Turn the rotary switch (3) downwards until the stabilizer feet are extended and touching the ground gently.

Opening the platform



- ▶ Turn the rotary switches **(2)** and **(5)** downwards simultaneously and hold both until the platform is in the horizontal operating position.

If optional load securing is present, the platform first lowers and then folds into the horizontal operating position.

Lowering the platform



- ▶ Turn the rotary switches **(4)** and **(5)** downwards simultaneously and hold both until the platform has been set down on the ground.

After the platform has been set down on the ground, it tilts and aligns with the ground.

Lifting the platform



- ▶ Turn the rotary switches **(4)** and **(5)** upwards simultaneously and hold both until the platform has reached the vehicle bed.

The platform first tilts into the horizontal or preset position before lifting.

Closing the platform



- ▶ Turn the rotary switches **(2)** and **(5)** upwards simultaneously and hold both in this position until the platform has closed.

If optional load securing is present, the platform first only closes to around 80° and lowers slightly. It then moves into the vertical transport position and lifts into the load securing device.

Retracting the hydraulic stabilizer feet

- ▶ Turn the rotary switch **(3)** upwards until the hydraulic stabilizer feet are retracted completely.

A 8.1.5. Operation via the two hand control and hydraulic underride guard

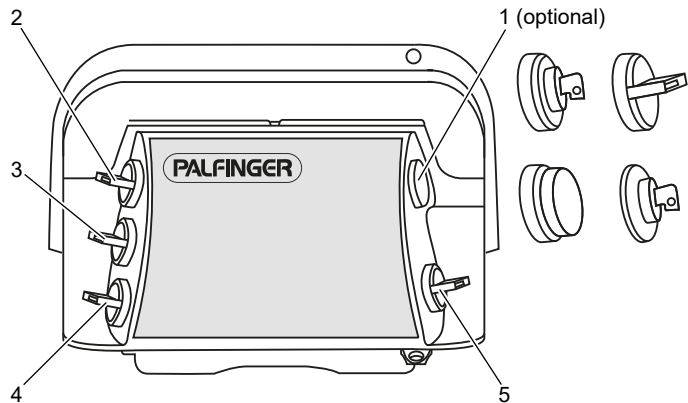

- 1 optional: Key switch, rotary switch, emergency stop button, E30 key
- 2 Rotary switch: Open/Close
- 3 Rotary switch: Lift/lower the underride guard
- 4 Rotary switch: Lift/lower
- 5 Rotary switch: Additional switch



DANGER!

Risk of accidents and injuries!

When operating the tail lift, personal injury and damage to property may occur if you do not follow the instructions in the “General operation” chapter.

- ▶ First read the “General operation” chapter from page 33 before operating your tail lift.

Lifting the hydraulic underride guard

- ▶ Turn the rotary switch (3) upwards until the underride guard has reached the upper limit position.

Opening the platform



- ▶ Turn the rotary switches **(2)** and **(5)** downwards simultaneously and hold both until the platform is in the horizontal operating position.

If optional load securing is present, the platform first lowers and then folds into the horizontal operating position.

Lowering the platform



- ▶ Turn the rotary switches **(4)** and **(5)** downwards simultaneously and hold both until the platform has been set down on the ground.

After the platform has been set down on the ground, it tilts and aligns with the ground.

Lifting the platform



- ▶ Turn the rotary switches **(4)** and **(5)** upwards simultaneously and hold both until the platform has reached the vehicle bed.

The platform first tilts into the horizontal or preset position before lifting.

Closing the platform



- ▶ Turn the rotary switches **(2)** and **(5)** upwards simultaneously and hold both in this position until the platform has closed.

If optional load securing is present, the platform first only closes to around 80° and lowers slightly. It then moves into the vertical transport position and lifts into the load securing device.

Lowering the hydraulic underride guard

- ▶ Turn the rotary switch **(3)** downwards until the underride guard has reached the lower limit position.

A 8.1.6. Operation via the Slimpanel and hydraulic underride guard

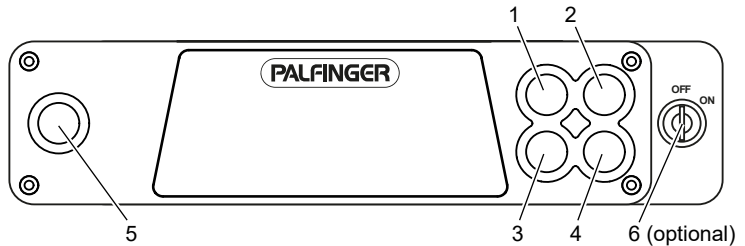

- 1 Function pushbutton 1
- 2 Function pushbutton 2
- 3 Function pushbutton 3
- 4 Function pushbutton 4
- 5 Additional pushbutton
- 6 optional: Key switch



DANGER!

Risk of accidents and injuries!

When operating the tail lift, personal injury and damage to property may occur if you do not follow the instructions in the “General operation” chapter.

- ▶ First read the “General operation” chapter from page 33 before operating your tail lift.

Lifting the hydraulic underride guard

- ▶ Press and hold the additional pushbutton **(5)** and the function pushbuttons **(1)** and **(3)** simultaneously until the underride guard has reached the upper limit position

Opening the platform



- ▶ Press and hold the additional pushbutton **(5)** and the function pushbutton **(4)** simultaneously until the platform aligns with the ground.

Lowering the platform



- ▶ Press and hold the additional pushbutton **(5)** and the function pushbutton **(3)** simultaneously until the platform aligns with the ground.

After the platform has been set down on the ground, it tilts and aligns with the ground.

Lifting the platform



- ▶ Press and hold the additional pushbutton **(5)** and the function pushbutton **(1)** simultaneously until the platform has reached the vehicle bed.

The platform first tilts into the horizontal or preset position before lifting.

Closing the platform



- ▶ Press and hold the additional pushbutton **(5)** and the function pushbutton **(2)** simultaneously until the platform is closed.

If optional load securing is present, the platform first only closes to around 80° and lowers slightly. It then moves into the vertical transport position and lifts into the load securing device.

Lowering the hydraulic underride guard

- ▶ Press and hold the additional pushbutton **(5)** and the function pushbuttons **(2)** and **(4)** simultaneously until the underride guard has reached the lower limit position.

A 8.1.7. Operation via the one hand control

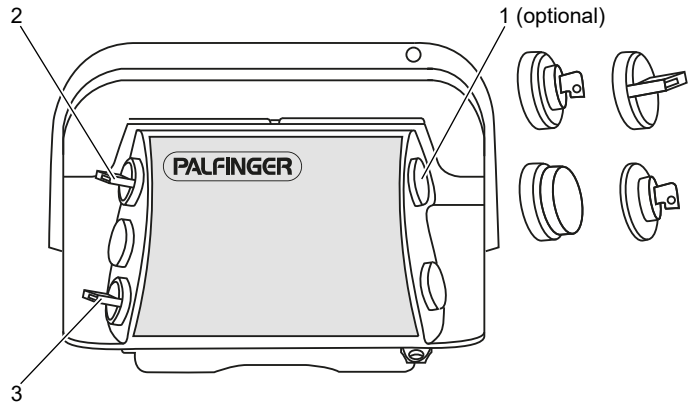

- 1 optional: Key switch, rotary switch, emergency stop button, E30 key
- 2 Rotary switch: Open/Close
- 3 Rotary switch: Lift/lower



DANGER!

Risk of accidents and injuries!

When operating the tail lift, personal injury and damage to property may occur if you do not follow the instructions in the “General operation” chapter.

- ▶ First read the “General operation” chapter from page 33 before operating your tail lift.

Opening the platform



- ▶ Turn the rotary switch (2) downwards and hold it until the platform is in the horizontal operating position.

If optional load securing is present, the platform first lowers and then folds into the horizontal operating position.

Lowering the platform



- ▶ Turn the rotary switch **(3)** downwards and hold it until the platform aligns with the ground.

After the platform has been set down on the ground, it tilts and aligns with the ground.

Lifting the platform



- ▶ Turn the rotary switch **(3)** upwards and hold it until the platform has reached the vehicle bed.

The platform first tilts into the horizontal or preset position before lifting.

Closing the platform



- ▶ Turn the rotary switch **(2)** upwards and hold it in this position until the platform has closed.

If optional load securing is present, the platform first only closes to around 80° and lowers slightly. It then moves into the vertical transport position and lifts into the load securing device.

A 8.1.8. Operation via the one hand control and hydraulic stabilizer feet

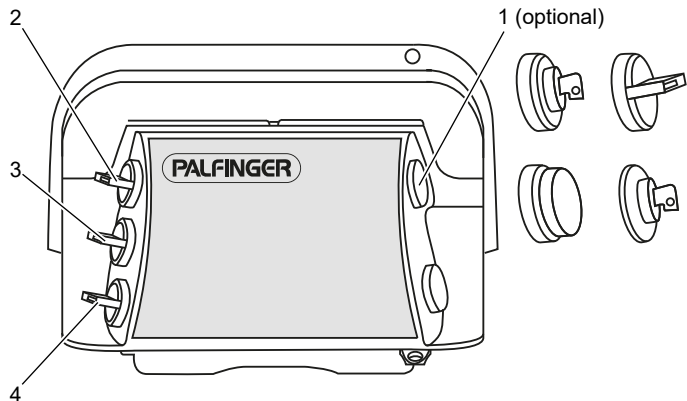

- 1 optional: Key switch, rotary switch, emergency stop button, E30 key
- 2 Rotary switch: Open/Close
- 3 Rotary switch: Retracting and extending
- 4 Rotary switch: Lift/lower



DANGER!

Risk of accidents and injuries!

When operating the tail lift, personal injury and damage to property may occur if you do not follow the instructions in the “General operation” chapter.

- ▶ First read the “General operation” chapter from page 33 before operating your tail lift.

Extending the hydraulic stabilizer feet

- ▶ Turn the rotary switch **(3)** downwards until the stabilizer feet are extended and touching the ground gently.

Opening the platform



- ▶ Turn the rotary switch **(2)** downwards and hold it until the platform is in the horizontal operating position.

If optional load securing is present, the platform first lowers and then folds into the horizontal operating position.

Lowering the platform



- ▶ Turn the rotary switch **(4)** downwards and hold it in this position until the platform aligns with the ground.

After the platform has been set down on the ground, it tilts and aligns with the ground.

Lifting the platform



- ▶ Turn the rotary switch **(4)** upwards and hold it in this position until the platform has reached the vehicle bed.

The platform first tilts into the horizontal or preset position before lifting.

Closing the platform



- ▶ Turn the rotary switch **(2)** upwards and hold it in this position until the platform has closed.

If optional load securing is present, the platform first only closes to around 80° and lowers slightly. It then moves into the vertical transport position and lifts into the load securing device.

Retracting the hydraulic stabilizer feet

- ▶ Turn the rotary switch **(3)** upwards until the stabilizer feet are retracted.

A 8.1.9. Operation via the Slimpanel and hydraulic stabilizer feet

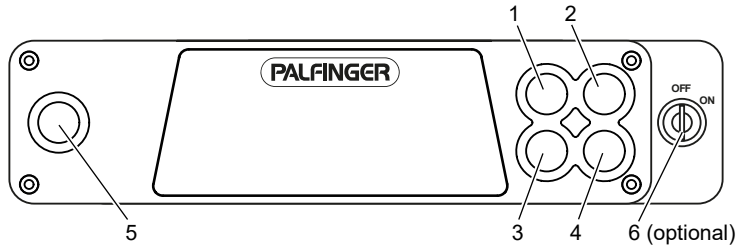

- 1 Function pushbutton 1
- 2 Function pushbutton 2
- 3 Function pushbutton 3
- 4 Function pushbutton 4
- 5 Additional pushbutton
- 6 optional: Key switch

DANGER!

Risk of accidents and injuries!

When operating the tail lift, personal injury and damage to property may occur if you do not follow the instructions in the “General operation” chapter.

- ▶ First read the “General operation” chapter from page 33 before operating your tail lift.



Extending the hydraulic stabilizer feet

- ▶ Press and hold the additional pushbutton **(5)** and the function pushbuttons **(1)** and **(3)** until the stabilizer feet are extended and touching the ground gently.

Opening the platform



- ▶ Press and hold the additional pushbutton **(5)** and the function pushbutton **(4)** until the platform is in the horizontal operating position.

If optional load securing is present, the platform first lowers and then folds into the horizontal operating position.

Lowering the platform



- ▶ Press and hold the additional pushbutton **(5)** and the function pushbutton **(3)** until the platform aligns with the ground.

After the platform has been set down on the ground, it tilts and aligns with the ground.

Lifting the platform



- ▶ Press and hold the additional pushbutton **(5)** and the function pushbutton **(1)** until the platform has reached the vehicle bed.

The platform first tilts into the horizontal or preset position before lifting.

Closing the platform



- ▶ Press and hold the additional pushbutton **(5)** and the function pushbutton **(2)** until the platform is closed.

If optional load securing is present, the platform first only closes to around 80° and lowers slightly. It then moves into the vertical transport position and lifts into the load securing device.

Retracting the hydraulic stabilizer feet

- ▶ Press and hold the additional pushbutton **(5)** and the function pushbuttons **(2)** and **(4)** until the stabilizer feet are retracted completely.

8.1.10. Optional: Quick down with two hand control

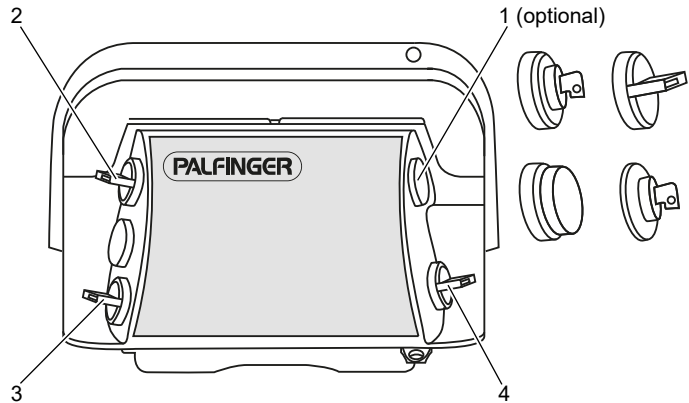

- 1 optional: Key switch, rotary switch, emergency stop button, E30 key
- 2 Rotary switch: Open/Close
- 3 Rotary switch: Lift/lower
- 4 Rotary switch: Additional switch

DANGER!

Risk of accidents and injuries!

When operating the tail lift, personal injury and damage to property may occur if you do not follow the instructions in the “General operation” chapter.

- First read the “General operation” chapter from page 33 before operating your tail lift.



Opening and lowering the platform

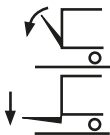

- Turn the rotary switches **(3)** and **(4)** downwards until the platform has aligned with the ground.

The platform opens and lowers simultaneously and aligns with the ground.

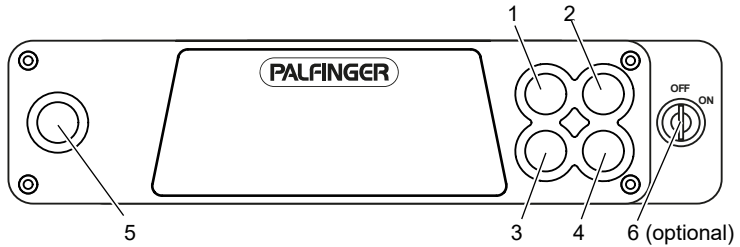
A 8.1.11. Optional: Quick down (with Slimpanel)

- 1 Function pushbutton 1
- 2 Function pushbutton 2
- 3 Function pushbutton 3
- 4 Function pushbutton 4
- 5 Additional pushbutton
- 6 optional: Key switch

DANGER!**Risk of accidents and injuries!**

When operating the tail lift, personal injury and damage to property may occur if you do not follow the instructions in the “General operation” chapter.

- ▶ First read the “General operation” chapter from page 33 before operating your tail lift.

Opening and lowering the platform

- ▶ Press and hold the additional pushbutton (5) and the function pushbutton (3) until the platform aligns with the ground.



The platform opens and lowers simultaneously and aligns with the ground.

F 8.1.12. Operation via the two hand control

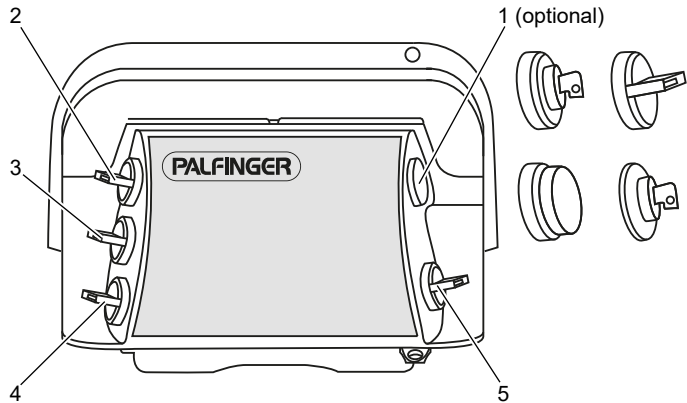

- 1 optional: Key switch, rotary switch, emergency stop button, E30 key
- 2 Rotary switch: Open/Close
- 3 Rotary switch: Retracting and extending
- 4 Rotary switch: Lift/lower
- 5 Rotary switch: Additional switch

DANGER!

Risk of accidents and injuries!

When operating the tail lift, personal injury and damage to property may occur if you do not follow the instructions in the “General operation” chapter.

- ▶ First read the “General operation” chapter from page 33 before operating your tail lift.



Extending and unfolding the platform

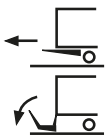

- ▶ Turn the rotary switches **(4)** and **(5)** downwards simultaneously and hold both in this position until the platform has lowered.

The platform lowers in order to be able to extend without hindrances.

- ▶ Turn the rotary switch **(3)** downwards and hold it until the platform is extended completely.

- ▶ Turn the rotary switches **(4)** and **(5)** downwards simultaneously and hold both until the folded platform has been set down on the ground.
- ▶ Wear gloves to protect your hands.
- ▶ Pull the handle with both hands to unfold the folding part of the platform.

Lowering the platform



- ▶ Turn the rotary switches **(4)** and **(5)** downwards simultaneously and hold both in this position until the platform is set down on the ground and has aligned with the ground.

After the platform has been set down on the ground, it tilts and aligns with the ground.

Lifting the platform



- ▶ Turn the rotary switches **(4)** and **(5)** upwards simultaneously and hold both in this position until the platform has reached the vehicle bed.

The platform tilts into the horizontal or preset position and then lifts.

Folding in and retracting the platform

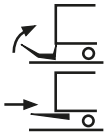

- ▶ Wear gloves to protect your hands.
- ▶ Pull the handle with both hands to fold the folding part of the platform in.
- ▶ Turn the rotary switches **(4)** and **(5)** upwards simultaneously and hold both until the platform has reached the retraction height.
- ▶ Turn the rotary switch **(3)** upwards and hold it until the platform is retracted completely. Ensure that the platform can retract without hindrances.

F 8.1.13. Operation via the Slimpanel

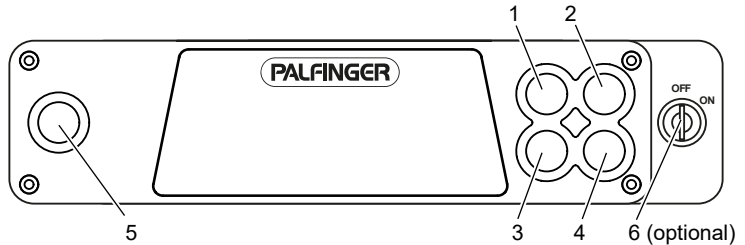

- 1 Function pushbutton 1
- 2 Function pushbutton 2
- 3 Function pushbutton 3
- 4 Function pushbutton 4
- 5 Additional pushbutton
- 6 optional: Key switch

DANGER!

Risk of accidents and injuries!



When operating the tail lift, personal injury and damage to property may occur if you do not follow the instructions in the “General operation” chapter.

- ▶ First read the “General operation” chapter from page 33 before operating your tail lift.

Extending and unfolding the platform

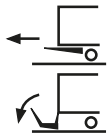

- ▶ Press and hold the additional pushbutton **(5)** and the function pushbutton **(3)** until the platform is lowered.

The platform lowers in order to be able to extend without hindrances.

- ▶ Press and hold the additional pushbutton **(5)** and the function pushbuttons **(1)** and **(2)** until the platform is extended completely.
- ▶ Press and hold the additional pushbutton **(5)** and the function pushbutton **(3)** until the folded platform is set down on the ground.
- ▶ Wear gloves to protect your hands.
- ▶ Pull the handle with both hands to unfold the folding part of the platform.

Lowering the platform



- ▶ Press and hold the additional pushbutton **(5)** and the function pushbutton **(3)** until the platform is set down on the ground and has aligned with the ground.

After the platform has been set down on the ground, it tilts and aligns with the ground.

Lifting the platform



- ▶ Press and hold the additional pushbutton **(5)** and the function pushbutton **(1)** until the platform has reached the vehicle bed.

The platform first tilts into the horizontal or preset position and then lifts.

Folding in and retracting the platform

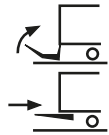

- ▶ Wear gloves to protect your hands.
- ▶ Pull the handle with both hands to fold the folding part of the platform in.
- ▶ Press and hold the additional pushbutton **(5)** and the function pushbutton **(1)** until the platform has reached the retraction height.
- ▶ Press and hold the additional pushbutton **(5)** and the function pushbuttons **(3)** and **(4)** until the platform is retracted completely. Ensure that the platform can retract without hindrances.
- ▶ Press and hold the additional pushbutton **(5)** and the function pushbutton **(1)** until the platform has reached the vibration safeguard.

Adjusting the platform tilt

- ▶ Press the additional pushbutton **(5)** and the function pushbutton **(2)** or **(4)** to adjust the platform tilt upwards or downwards.

F 8.1.14. Operation via the easy move® two hand control

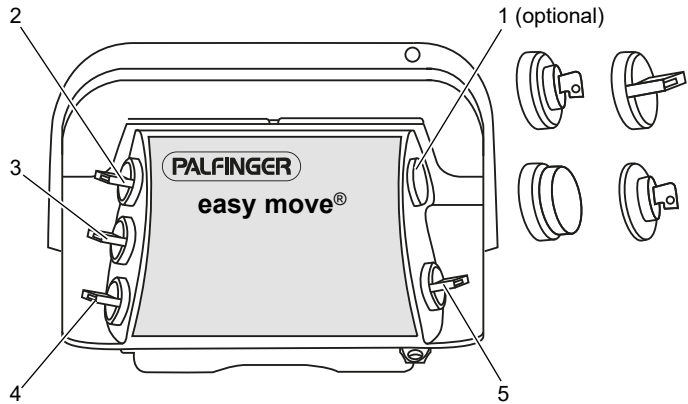

- 1 optional: Key switch, rotary switch, emergency stop button, E30 key
- 2 Rotary switch: Open/Close
- 3 Rotary switch: Retracting and extending
- 4 Rotary switch: Lift/lower
- 5 Rotary switch: Additional switch

DANGER!

Risk of accidents and injuries!

When operating the tail lift, personal injury and damage to property may occur if you do not follow the instructions in the “General operation” chapter.

- ▶ First read the “General operation” chapter from page 33 before operating your tail lift.



Extending and unfolding the platform

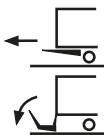

- ▶ Turn the rotary switch (3) downwards and hold it in this position until the platform is extended.

The platform lowers in order to be able to extend without hindrances and extends.

- ▶ Turn the rotary switches **(4)** and **(5)** downwards simultaneously and hold both until the folded platform has been set down on the ground.
- ▶ Wear gloves to protect your hands.
- ▶ Pull the handle with both hands to unfold the folding part of the platform.

Lowering the platform



- ▶ Turn the rotary switches **(4)** and **(5)** downwards simultaneously and hold both in this position until the platform is set down on the ground and has aligned with the ground.

After the platform has been set down on the ground, it tilts and aligns with the ground.

Lifting the platform



- ▶ Turn the rotary switches **(4)** and **(5)** upwards simultaneously and hold both in this position until the platform has reached the vehicle bed.

The platform tilts into the horizontal or preset position and then lifts.

Folding in and retracting the platform

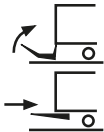

- ▶ Wear gloves to protect your hands.
- ▶ Pull the handle with both hands to fold the folding part of the platform in.
- ▶ Turn the rotary switch **(3)** upwards and hold it until the platform is retracted completely. Ensure that the platform can retract without hindrances.

The folded platform lifts or lowers automatically until the optimum retraction position is reached. The platform then retracts to the limit position and lifts against the vibration safeguard.

F 8.1.15. Operation via the easy move® one hand control

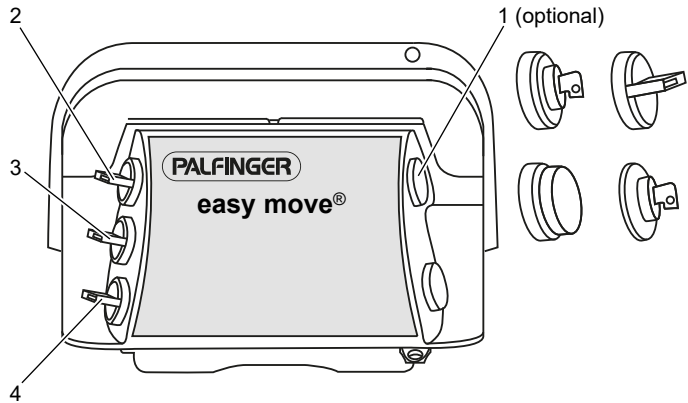

- 1 optional: Key switch, rotary switch, emergency stop button, E30 key
- 2 Rotary switch: Open/Close
- 3 Rotary switch: Retracting and extending
- 4 Rotary switch: Lift/lower

DANGER!

Risk of accidents and injuries!

When operating the tail lift, personal injury and damage to property may occur if you do not follow the instructions in the “General operation” chapter.

- ▶ First read the “General operation” chapter from page 33 before operating your tail lift.



Extending and unfolding the platform

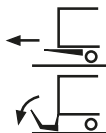

- ▶ Turn the rotary switch **(3)** downwards and hold it in this position until the platform is extended.

The platform lowers in order to be able to extend without hindrances and extends.

- ▶ Turn the rotary switch **(4)** downwards and hold it until the folded platform has been set down on the ground.
- ▶ Wear gloves to protect your hands.

- ▶ Pull the handle with both hands to unfold the folding part of the platform.

Lowering the platform



- ▶ Turn the rotary switch **(4)** downwards and hold it in this position until the platform is set down on the ground and has aligned with the ground.

After the platform has been set down on the ground, it tilts and aligns with the ground.

Lifting the platform



- ▶ Turn the rotary switch **(4)** upwards and hold it in this position until the platform has reached the vehicle bed.

The platform tilts into the horizontal or preset position and then lifts.

Folding in and retracting the platform

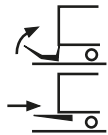

- ▶ Wear gloves to protect your hands.
- ▶ Pull the handle with both hands to fold the folding part of the platform in.
- ▶ Turn the rotary switch **(3)** upwards and hold it until the platform is retracted completely. Ensure that the platform can retract without hindrances.

The folded platform lifts or lowers automatically until the optimum retraction position is reached. The platform then retracts to the limit position and moves against the vibration safeguard.

F 8.1.16. Operation via the easy move® Slimpanel

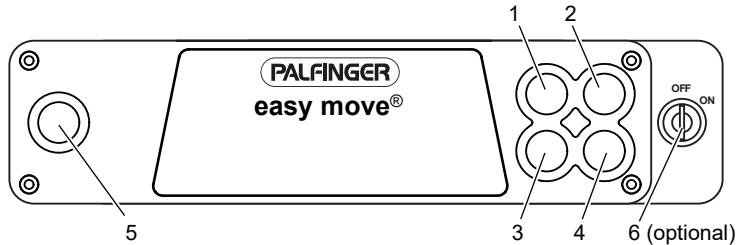

- 1 Function pushbutton 1
- 2 Function pushbutton 2
- 3 Function pushbutton 3
- 4 Function pushbutton 4
- 5 Additional pushbutton
- 6 optional: Key switch

DANGER!

Risk of accidents and injuries!

When operating the tail lift, personal injury and damage to property may occur if you do not follow the instructions in the “General operation” chapter.

- ▶ First read the “General operation” chapter from page 33 before operating your tail lift.



Extending and unfolding the platform

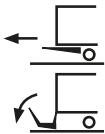

- ▶ Press and hold the additional pushbutton **(5)** and the function pushbuttons **(1)** and **(2)** until the platform is set down on the ground.

The platform lowers in order to be able to extend without hindrances, extends and lowers onto the ground.

- ▶ Wear gloves to protect your hands.
- ▶ Pull the handle with both hands to unfold the folding part of the platform.

Lowering the platform



- ▶ Press and hold the additional pushbutton **(5)** and the function pushbutton **(3)** until the platform is set down on the ground and has aligned with the ground.

After the platform has been set down on the ground, it tilts and aligns with the ground.

Lifting the platform



- ▶ Press and hold the additional pushbutton **(5)** and the function pushbutton **(1)** until the platform has reached the vehicle bed.

The platform first tilts into the horizontal or preset position and then lifts.

Folding in and retracting the platform

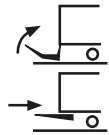

- ▶ Wear gloves to protect your hands.
- ▶ Pull the handle with both hands to fold the folding part of the platform in.
- ▶ Press and hold the additional pushbutton **(5)** and the function pushbuttons **(3)** and **(4)** until the platform is retracted completely. Ensure that the platform can retract without hindrances.

The folded platform lifts or lowers automatically until the optimum retraction position is reached. The platform then retracts to the limit position and lifts against the vibration safeguard.

Adjusting the platform tilt

- ▶ Press the additional pushbutton **(5)** and the function pushbutton **(2)** or **(4)** to adjust the platform tilt upwards or downwards.

F 8.1.17. Operation via the two hand control for R 1500 L FLAT

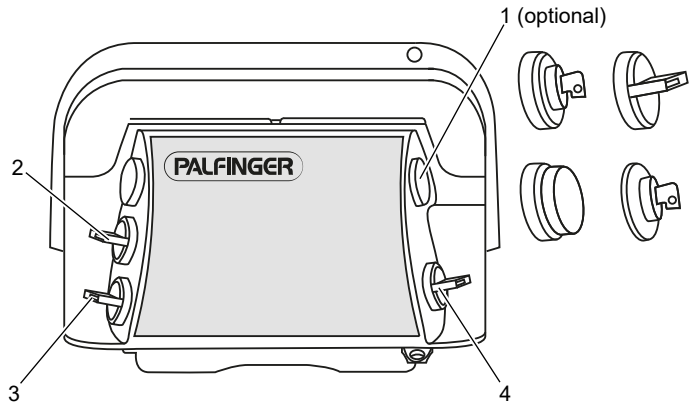

- 1 optional: Key switch, rotary switch, emergency stop button, E30 key
- 2 Rotary switch: Retracting and extending
- 3 Rotary switch: Lift/lower
- 4 Rotary switch: Additional switch

DANGER!

Risk of accidents and injuries!

When operating the tail lift, personal injury and damage to property may occur if you do not follow the instructions in the “General operation” chapter.

- ▶ First read the “General operation” chapter from page 33 before operating your tail lift.



Extending and unfolding the platform

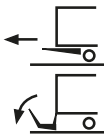

- ▶ Turn the rotary switches (3) and (4) downwards simultaneously and hold both in this position until the platform has lowered.
- The platform lowers in order to be able to extend without hindrances.
- ▶ Turn the rotary switch (2) downwards and hold it until the platform is extended completely.
 - ▶ Turn the rotary switches (3) and (4) downwards simultaneously and hold both until the folded platform has been set down on the ground.

- ▶ Wear gloves to protect your hands.
- ▶ Pull the handle with both hands to unfold the folding part of the platform.

Lowering the platform



- ▶ Turn the rotary switches **(3)** and **(4)** downwards simultaneously and hold both in this position until the platform is set down on the ground and has aligned with the ground.

Lifting the platform



- ▶ Turn the rotary switches **(3)** and **(4)** upwards simultaneously and hold both in this position until the platform has reached the vehicle bed.

Folding in and retracting the platform

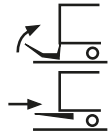

- ▶ Wear gloves to protect your hands.
- ▶ Pull the handle with both hands to fold the folding part of the platform in.
- ▶ Turn the rotary switches **(3)** and **(4)** upwards simultaneously and hold both until the platform has reached the retraction height.
- ▶ Turn the rotary switch **(2)** upwards and hold it until the platform is retracted completely. Ensure that the platform can retract without hindrances.
- ▶ Turn the rotary switches **(3)** and **(4)** upwards simultaneously and hold both until the platform has reached the vibration safeguard.

F 8.1.18. Operation via the one hand control for R 1500 L FLAT

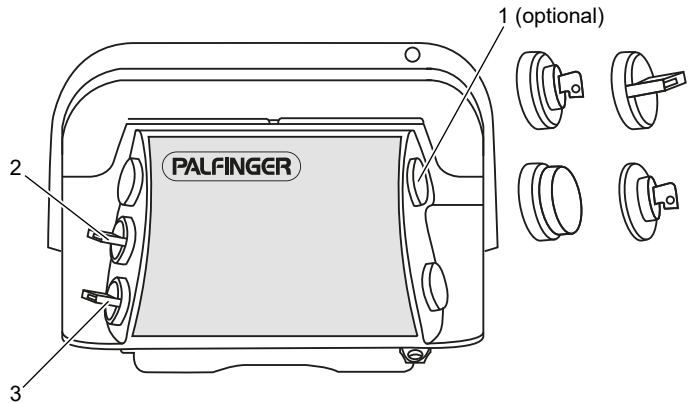

- 1 optional: Key switch, rotary switch, emergency stop button, E30 key
- 2 Rotary switch: Retracting and extending
- 3 Rotary switch: Lift/lower

DANGER!

Risk of accidents and injuries!



When operating the tail lift, personal injury and damage to property may occur if you do not follow the instructions in the “General operation” chapter.

- ▶ First read the “General operation” chapter from page 33 before operating your tail lift.

Extending and unfolding the platform

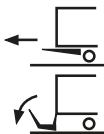

- ▶ Turn the rotary switch **(3)** downwards and hold it in this position until the platform has lowered.

The platform lowers in order to be able to extend without hindrances.

- ▶ Turn the rotary switch **(2)** downwards and hold it until the platform is extended completely.
- ▶ Turn the rotary switch **(3)** downwards and hold it until the folded platform has been set down on the ground.
- ▶ Wear gloves to protect your hands.

- ▶ Pull the handle with both hands to unfold the folding part of the platform.

Lowering the platform



- ▶ Turn the rotary switch **(3)** downwards and hold it in this position until the platform is set down on the ground and has aligned with the ground.

Lifting the platform



- ▶ Turn the rotary switch **(3)** upwards and hold it in this position until the platform has reached the vehicle bed.

Folding in and retracting the platform

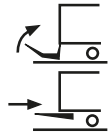

- ▶ Wear gloves to protect your hands.
- ▶ Pull the handle with both hands to fold the folding part of the platform in.
- ▶ Turn the rotary switch **(3)** upwards and hold it until the platform has reached the retraction height.
- ▶ Turn the rotary switch **(2)** upwards and hold it until the platform is retracted completely. Ensure that the platform can retract without hindrances.
- ▶ Turn the rotary switch **(3)** upwards and hold it until the platform has reached the vibration safeguard.

F 8.1.19. Operation via the Slimpanel for R 1500 L FLAT

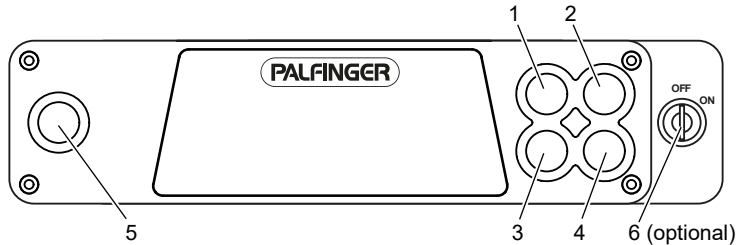

- 1 Function pushbutton 1
- 2 Function pushbutton 2
- 3 Function pushbutton 3
- 4 Function pushbutton 4
- 5 Additional pushbutton
- 6 optional: Key switch

DANGER!

Risk of accidents and injuries!



When operating the tail lift, personal injury and damage to property may occur if you do not follow the instructions in the “General operation” chapter.

- ▶ First read the “General operation” chapter from page 33 before operating your tail lift.

Extending and unfolding the platform

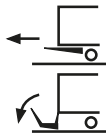

- ▶ Press and hold the additional pushbutton **(5)** and the function pushbuttons **(1)** and **(2)** until the platform has lowered and is extended.

The platform lowers slightly and then extends.

- ▶ Wear gloves to protect your hands.
- ▶ Pull the handle with both hands to unfold the folding part of the platform.

Lowering the platform



- ▶ Press and hold the additional pushbutton **(5)** and the function pushbutton **(3)** until the platform is set down on the ground and has aligned with the ground.

After the platform has been set down on the ground, it tilts and aligns with the ground.

Lifting the platform



- ▶ Press and hold the additional pushbutton **(5)** and the function pushbutton **(1)** until the platform has reached the vehicle bed.

The platform tilts into the horizontal or preset position and then lifts.

Folding in and retracting the platform

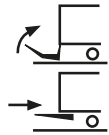

- ▶ Wear gloves to protect your hands.
- ▶ Pull the handle with both hands to fold the folding part of the platform in.
- ▶ Press and hold the additional pushbutton **(5)** and the function pushbutton **(1)** until the platform has reached the retraction height.
- ▶ Press and hold the additional pushbutton **(5)** and the function pushbuttons **(3)** and **(4)** until the platform is retracted and has reached the vibration safeguard. Ensure that the platform can retract without hindrances.

G 8.1.20. Operation via the two hand control for R 1500 SH – R 2000 LH (double-folding platform)

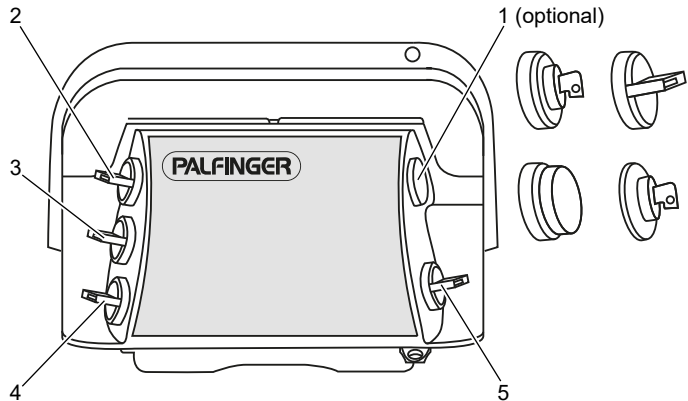

- 1 optional: Key switch, rotary switch, emergency stop button, E30 key
- 2 Rotary switch: Open/Close
- 3 Rotary switch: Retracting and extending
- 4 Rotary switch: Lift/lower
- 5 Rotary switch: Additional switch

DANGER!

Risk of accidents and injuries!



When operating the tail lift, personal injury and damage to property may occur if you do not follow the instructions in the “General operation” chapter.

- ▶ First read the “General operation” chapter from page 33 before operating your tail lift.

Extending and unfolding the platform

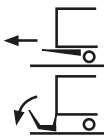

- ▶ Turn the rotary switch **(3)** downwards and hold it in this position until the platform is unfolded once.

The platform lowers slightly and then extends. It then lowers to the ground and unfolds once.

- ▶ Wear gloves to protect your hands.

- ▶ Pull the handle with both hands to unfold the folding part of the platform.

Lifting the platform



- ▶ Turn the rotary switches **(4)** and **(5)** upwards simultaneously and hold both until the platform has reached the vehicle bed.

The platform tilts into the horizontal or preset position and then lifts.

Lowering the platform



- ▶ Turn the rotary switches **(4)** and **(5)** downwards simultaneously and hold both until the platform is set down on the ground and has aligned with the ground.

After the platform has been set down on the ground, it tilts and aligns with the ground.

Adjusting the BDF position

- ▶ Turn the rotary switches **(4)** and **(5)** upwards simultaneously and hold both until the platform has reached the vehicle bed height.
- ▶ Turn the rotary switch **(3)** upwards and hold it until the platform touches the structure.
- ▶ Check the alignment to the bed and re-adjust if necessary.
- ▶ Move the contact plate on the movement rail until it is above the outer proximity switch (see chapter 6.6, page 30).

Approaching the BDF position

- ▶ Turn the rotary switches **(4)** and **(5)** upwards simultaneously and hold both until the torsion frame is above its horizontal position.
- ▶ Turn the rotary switch **(3)** upwards.

The platform moves into the set BDF position.

- ▶ Turn the rotary switches **(4)** and **(5)** upwards simultaneously and hold both until the platform is in the loading position.

Folding in and retracting the platform

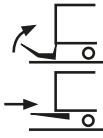

- ▶ Turn the rotary switches **(4)** and **(5)** downwards simultaneously and hold both in this position until the platform has reached the ground.
- ▶ Wear gloves to protect your hands.
- ▶ Pull the handle with both hands to fold the folding part of the platform in.
- ▶ Turn the rotary switch **(3)** upwards and hold it in this position until the platform has reached the vibration safeguard.

The platform folds over automatically and then lifts into the retraction position. It then retracts completely and lifts against the vibration safeguard.

G 8.1.21. Operation via the Slimpanel for R 1500 SH – R 2000 SH

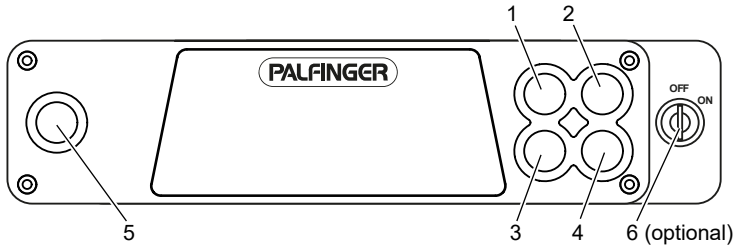

- 1 Function pushbutton 1
- 2 Function pushbutton 2
- 3 Function pushbutton 3
- 4 Function pushbutton 4
- 5 Additional pushbutton
- 6 optional: Key switch

DANGER!

Risk of accidents and injuries!



When operating the tail lift, personal injury and damage to property may occur if you do not follow the instructions in the “General operation” chapter.

- ▶ First read the “General operation” chapter from page 33 before operating your tail lift.

Extending and unfolding the platform

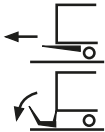

- ▶ Press and hold the additional pushbutton (5) and the function pushbuttons (1) and (2) until the platform is unfolded once.

The platform lowers slightly and then extends. It then lowers to the ground and unfolds once.

- ▶ Wear gloves to protect your hands.
- ▶ Pull the handle with both hands to unfold the folding part of the platform.

Lifting the platform



- ▶ Press and hold the additional pushbutton **(5)** and the function pushbutton **(1)** until the platform has reached the vehicle bed.

The platform tilts into the horizontal or preset position and then lifts.

Lowering the platform



- ▶ Press and hold the additional pushbutton **(5)** and the function pushbutton **(3)** until the platform is set down on the ground and has aligned with the ground.

After the platform has been set down on the ground, it tilts and aligns with the ground.

Adjusting the BDF position

- ▶ Press and hold the additional pushbutton **(5)** and the function pushbutton **(1)** until the platform has reached the vehicle bed height.
- ▶ Press and hold the additional pushbutton **(5)** and the function pushbuttons **(3)** and **(4)** until the platform touches the structure.
- ▶ Check the alignment to the bed and re-adjust if necessary.
- ▶ Move the contact plate on the movement rail until it is above the outer proximity switch (see chapter 6.6, page 30).

Approaching the BDF position

- ▶ Press and hold the additional pushbutton **(5)** and the function pushbutton **(1)** until the torsion frame is above its horizontal position.
- ▶ Press and hold the additional pushbutton **(5)** and the function pushbuttons **(3)** and **(4)**.

The platform moves into the set BDF position.

- ▶ Press and hold the additional pushbutton **(5)** and the function pushbutton **(1)** until the platform has reached the loading position.

Folding in and retracting the platform

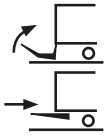

- ▶ Press and hold the additional pushbutton **(5)** and the function pushbutton **(3)** until the platform has reached the ground
- ▶ Wear gloves to protect your hands
- ▶ Pull the handle with both hands to fold the folding part of the platform in.
- ▶ Press and hold the additional pushbutton **(5)** and the function pushbuttons **(3)** and **(4)** until the platform has reached the vibration safeguard.

The platform folds over automatically and then lifts into the retraction position. It then retracts completely and lifts against the vibration safeguard.

**G 8.1.22. Operation via the two hand control for
R 750 SM – R 2000 LM (double-folding platform)**

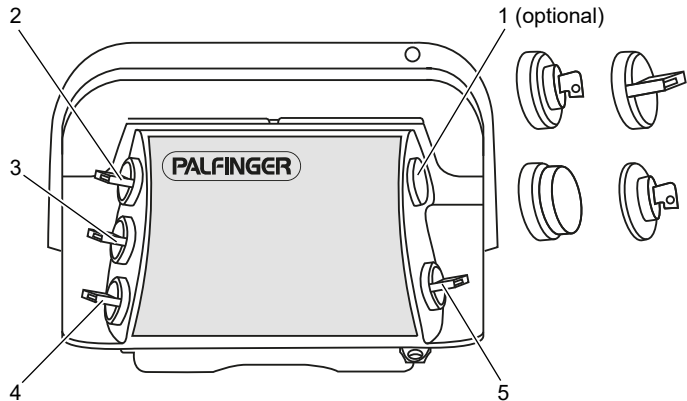

- 1 optional: Key switch, rotary switch, emergency stop button, E30 key
- 2 Rotary switch: Open/Close
- 3 Rotary switch: Retracting and extending
- 4 Rotary switch: Lift/lower
- 5 Rotary switch: Additional switch

DANGER!

Risk of accidents and injuries!

When operating the tail lift, personal injury and damage to property may occur if you do not follow the instructions in the “General operation” chapter.

- ▶ First read the “General operation” chapter from page 33 before operating your tail lift.



Extending and unfolding the platform

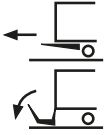

- ▶ Turn the rotary switches **(4)** and **(5)** downwards simultaneously and hold both in this position until the platform has lowered.

The platform lowers in order to be able to extend without hindrances.

- ▶ Turn the rotary switch **(3)** downwards and hold it until the platform is extended completely.
- ▶ Turn the rotary switches **(4)** and **(5)** downwards simultaneously and hold both until the folded platform has been set down on the ground.
- ▶ Wear gloves to protect your hands.
- ▶ Hold the platform edge with both hands to unfold the platform backwards.
- ▶ Pull the folding part of the platform with both hands to unfold it backwards.

Lowering the platform



- ▶ Turn the rotary switches **(4)** and **(5)** downwards simultaneously and hold both in this position until the platform is set down on the ground and has aligned with the ground.

After the platform has been set down on the ground, it tilts and aligns with the ground.

Lifting the platform



- ▶ Turn the rotary switches **(4)** and **(5)** upwards simultaneously and hold both in this position until the platform has reached the vehicle bed.

The platform tilts into the horizontal or preset position and then lifts.

Folding in and retracting the platform

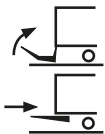

- ▶ Wear gloves to protect your hands.
- ▶ Pull the folding part of the platform with both hands to fold it in.
- ▶ Swing the platform to the roller on the stand tube.
- ▶ Turn the rotary switches **(4)** and **(5)** upwards simultaneously and hold both until the platform has reached the retraction height.

- ▶ Turn the rotary switch **(3)** upwards and hold it until the platform is retracted completely. Ensure that the platform can retract without hindrances.
- ▶ Turn the rotary switches **(4)** and **(5)** upwards simultaneously and hold both until the platform has reached the vibration safeguard.

G 8.1.23. Operation via the Slimpanel for R 750 SM – R 2000 LM (double-folding platform)

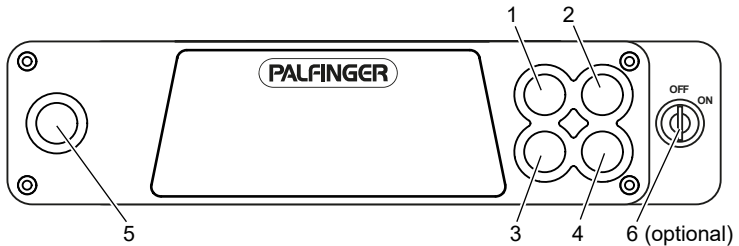

- 1 Function pushbutton 1
- 2 Function pushbutton 2
- 3 Function pushbutton 3
- 4 Function pushbutton 4
- 5 Additional pushbutton
- 6 optional: Key switch

DANGER!

Risk of accidents and injuries!



When operating the tail lift, personal injury and damage to property may occur if you do not follow the instructions in the “General operation” chapter.

- ▶ First read the “General operation” chapter from page 33 before operating your tail lift.

Extending and unfolding the platform

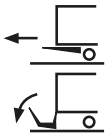

- ▶ Press and hold the additional pushbutton **(5)** and the function pushbutton **(3)** until the platform is lowered.

The platform lowers in order to be able to extend without hindrances.

- ▶ Press and hold the additional pushbutton **(5)** and the function pushbuttons **(1)** and **(2)** until the platform is extended completely.
- ▶ Press and hold the additional pushbutton **(5)** and the function pushbutton **(3)** until the folded platform is set down on the ground.
- ▶ Wear gloves to protect your hands.
- ▶ Hold the platform edge with both hands to unfold the platform backwards.

- ▶ Pull the folding part of the platform with both hands to unfold it backwards.

Lowering the platform



- ▶ Press and hold the additional pushbutton **(5)** and the function pushbutton **(3)** until the platform is set down on the ground and has aligned with the ground.

After the platform has been set down on the ground, it tilts and aligns with the ground.

Lifting the platform



- ▶ Press and hold the additional pushbutton **(5)** and the function pushbutton **(1)** until the platform has reached the vehicle bed.

The platform first tilts into the horizontal or preset position before lifting into the loading position.

Adjusting the BDF position

- ▶ Press and hold the additional pushbutton **(5)** and the function pushbutton **(1)** until the platform has reached the vehicle bed height.
- ▶ Press and hold the additional pushbutton **(5)** and the function pushbuttons **(3)** and **(4)** until the platform touches the structure.
- ▶ Check the alignment to the bed and re-adjust if necessary.
- ▶ Move the contact plate on the movement rail until it is above the outer proximity switch (see chapter 6.6, page 30).

Approaching the BDF position

- ▶ Press and hold the additional pushbutton **(5)** and the function pushbutton **(1)** until the torsion frame is above its horizontal position.
- ▶ Press and hold the additional pushbutton **(5)** and the function pushbuttons **(3)** and **(4)**.

The platform moves into the set BDF position.

- ▶ Press and hold the additional pushbutton **(5)** and the function pushbutton **(1)** until the platform has reached the loading position.

Folding in and retracting the platform

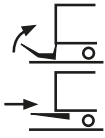

- ▶ Wear gloves to protect your hands.
- ▶ Pull the folding part of the platform with both hands to fold it in.
- ▶ Swing the platform to the roller on the stand tube.
- ▶ Press and hold the additional pushbutton **(5)** and the function pushbutton **(1)** until the platform has reached the retraction height.
- ▶ Press and hold the additional pushbutton **(5)** and the function pushbuttons **(3)** and **(4)** until the platform is retracted completely. Ensure that the platform can retract without hindrances.
- ▶ Press and hold the additional pushbutton **(5)** and the function pushbutton **(1)** until the platform has reached the vibration safeguard.

Adjusting the platform tilt

- ▶ Press the additional pushbutton **(5)** and the function pushbutton **(2)** or **(4)** to adjust the platform tilt upwards or downwards.

G 8.1.24. Operation via the easy move® two hand control for R 750 SM – R 2000 LM (double-folding platform)

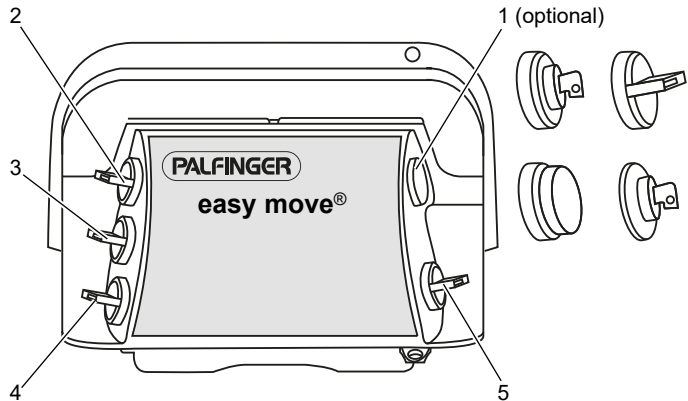

- 1 optional: Key switch, rotary switch, emergency stop button, E30 key
- 2 Rotary switch: Open/Close
- 3 Rotary switch: Retracting and extending
- 4 Rotary switch: Lift/lower
- 5 Rotary switch: Additional switch

DANGER!

Risk of accidents and injuries!



When operating the tail lift, personal injury and damage to property may occur if you do not follow the instructions in the “General operation” chapter.

- ▶ First read the “General operation” chapter from page 33 before operating your tail lift.

Extending and unfolding the platform

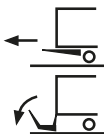

- ▶ Turn the rotary switch (3) downwards and hold it in this position until the platform is set down on the ground.

The platform lowers in order to be able to extend without hindrances, extends and lowers onto the ground.

- ▶ Wear gloves to protect your hands.

- ▶ Hold the platform edge with both hands to unfold the platform backwards.
- ▶ Pull the folding part of the platform with both hands to unfold it backwards.

Lifting the platform



- ▶ Turn the rotary switches **(4)** and **(5)** upwards simultaneously and hold both in this position until the platform has reached the vehicle bed.

The platform tilts into the horizontal or preset position and then lifts.

Lowering the platform



- ▶ Turn the rotary switches **(4)** and **(5)** downwards simultaneously and hold both in this position until the platform is set down on the ground and has aligned with the ground.

After the platform has been set down on the ground, it tilts and aligns with the ground.

Adjusting the BDF position

- ▶ Turn the rotary switches **(4)** and **(5)** upwards simultaneously and hold both until the platform has reached the vehicle bed height.
- ▶ Turn the rotary switch **(3)** upwards and hold it until the platform touches the structure.
- ▶ Check the alignment to the bed and re-adjust if necessary.
- ▶ Move the contact plate on the movement rail until it is above the outer proximity switch (see chapter 6.6, page 30).

Approaching the BDF position

- ▶ Turn the rotary switches **(4)** and **(5)** upwards simultaneously and hold both until the torsion frame is above its horizontal position.
- ▶ Turn the rotary switch **(3)** upwards.

The platform moves into the set BDF position.

- ▶ Turn the rotary switches **(4)** and **(5)** upwards simultaneously and hold both until the platform is in the loading position.

Folding in and retracting the platform

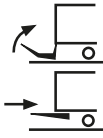

- ▶ Extend the system completely and lower it to the ground.
- ▶ Wear gloves to protect your hands.
- ▶ Pull the folding part of the platform with both hands to fold it in.
- ▶ Swing the platform to the roller on the stand tube.
- ▶ Turn the rotary switch **(3)** upwards and hold it in this position until the platform is retracted completely. Ensure that the platform can retract without hindrances.

The folded platform lifts or lowers automatically until the optimum retraction position is reached. The platform then retracts to the limit position and lifts against the vibration safeguard.

G 8.1.25. Operation via the easy move® Slimpanel for R 750 SM – R 2000 LM (double-folding platform)

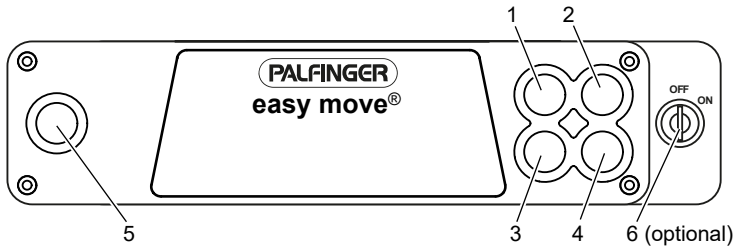

- 1 Function pushbutton 1
- 2 Function pushbutton 2
- 3 Function pushbutton 3
- 4 Function pushbutton 4
- 5 Additional pushbutton
- 6 optional: Key switch

DANGER!

Risk of accidents and injuries!



When operating the tail lift, personal injury and damage to property may occur if you do not follow the instructions in the “General operation” chapter.

- ▶ First read the “General operation” chapter from page 33 before operating your tail lift.

Extending and unfolding the platform

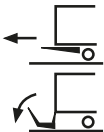

- ▶ Press and hold the additional pushbutton **(5)** and the function pushbuttons **(1)** and **(2)** until the platform is set down on the ground.

The platform lowers in order to be able to extend without hindrances, extends and lowers onto the ground.

- ▶ Wear gloves to protect your hands.
- ▶ Hold the platform edge with both hands to unfold the platform backwards.
- ▶ Pull the folding part of the platform with both hands to unfold it backwards.

Lowering the platform



- ▶ Press and hold the additional pushbutton **(5)** and the function pushbutton **(3)** until the platform aligns with the ground.

After the platform has been set down on the ground, it tilts and aligns with the ground.

Lifting the platform



- ▶ Press and hold the additional pushbutton **(5)** and the function pushbutton **(1)** until the platform has reached the vehicle bed.

The platform first tilts into the horizontal or preset position before lifting into the loading position.

Adjusting the BDF position

- ▶ Press and hold the additional pushbutton **(5)** and the function pushbutton **(1)** until the platform has reached the vehicle bed height.
- ▶ Press and hold the additional pushbutton **(5)** and the function pushbuttons **(3)** and **(4)** until the platform touches the structure.
- ▶ Check the alignment to the bed and re-adjust if necessary.
- ▶ Move the contact plate on the movement rail until it is above the outer proximity switch (see chapter 6.6, page 30).

Approaching the BDF position

- ▶ Press and hold the additional pushbutton **(5)** and the function pushbutton **(1)** until the torsion frame is above its horizontal position.
- ▶ Press and hold the additional pushbutton **(5)** and the function pushbuttons **(3)** and **(4)**.

The platform moves into the set BDF position.

- ▶ Press and hold the additional pushbutton **(5)** and the function pushbutton **(1)** until the platform has reached the loading position.

Folding in and retracting the platform

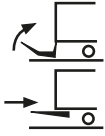

- ▶ Wear gloves to protect your hands.
- ▶ Pull the folding part of the platform with both hands to fold it in.
- ▶ Swing the platform to the roller on the stand tube.
- ▶ Press and hold the additional pushbutton **(5)** and the function pushbuttons **(3)** and **(4)** until the platform is retracted completely. Ensure that the platform can retract without hindrances.

The folded platform lifts or lowers automatically until the optimum retraction position is reached. The platform then retracts to the limit position and lifts against the vibration safeguard.

K 8.1.26. Operation via the two hand control

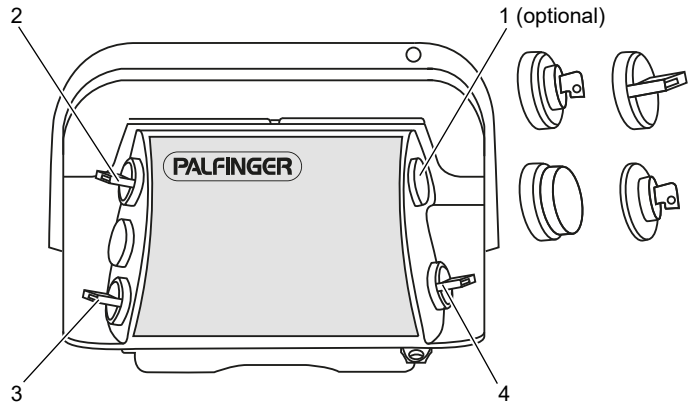

- 1 optional: Key switch, rotary switch, emergency stop button, E30 key
- 2 Rotary switch: Open/Close
- 3 Rotary switch: Lift/lower
- 4 Rotary switch: Additional switch



DANGER!

Risk of accidents and injuries!

When operating the tail lift, personal injury and damage to property may occur if you do not follow the instructions in the “General operation” chapter.

- ▶ First read the “General operation” chapter from page 33 before operating your tail lift.

Unfolding the platform



- ▶ Turn the rotary switches **(3)** and **(4)** downwards simultaneously and hold both in this position until the platform has reached the almost vertical position.

The platform lowers slightly and then swings over the deflection roller to almost the vertical position.

- ▶ Wear gloves to protect your hands.
- ▶ Pull the handle with both hands to unfold the platform backwards.

- ▶ Turn the rotary switches **(2)** and **(4)** downwards simultaneously and hold both in this position until the platform has reached the horizontal position.
- ▶ Use both hands to fold the folding part of the platform into the operating position.

Lowering the platform



- ▶ Turn the rotary switches **(3)** and **(4)** downwards simultaneously and hold both in this position until the platform has been set down on the ground.

After the platform has been set down on the ground, it tilts and aligns with the ground.

Lifting the platform



- ▶ Turn the rotary switches **(3)** and **(4)** upwards simultaneously and hold both in this position until the platform has reached the vehicle bed.

The platform tilts into the horizontal or preset position and then lifts.

Folding the platform in



- ▶ Ensure that the platform is in the horizontal position on the ground.
- ▶ Wear gloves to protect your hands.
- ▶ Use both hands to fold the folding part of the platform out of the operating position and onto the fixed part of the platform.
- ▶ Turn the rotary switches **(2)** and **(4)** upwards simultaneously and hold both in this position until the platform has reached the vertical position.
- ▶ Push the platform with both hands against the deflection roller.
- ▶ Turn the rotary switches **(3)** and **(4)** upwards simultaneously and hold both in this position until the platform has reached the transport position.

K 8.1.27. Operation via the one hand control

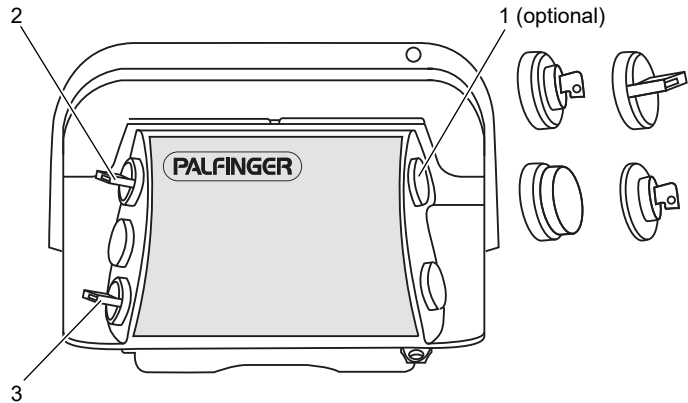

- 1 optional: Key switch, rotary switch, emergency stop button, E30 key
- 2 Rotary switch: Open/Close
- 3 Rotary switch: Lift/lower



DANGER!

Risk of accidents and injuries!

When operating the tail lift, personal injury and damage to property may occur if you do not follow the instructions in the “General operation” chapter.

- ▶ First read the “General operation” chapter from page 33 before operating your tail lift.

Unfolding the platform



- ▶ Turn the rotary switch **(3)** downwards and hold it in this position until the platform has reached the vertical position.

The platform lowers slightly and then swings over the deflection roller to almost the vertical position.

- ▶ Wear gloves to protect your hands.
- ▶ Pull the handle with both hands to unfold the platform backwards.
- ▶ Turn the rotary switch **(2)** downwards and hold it in this position until the platform has reached the horizontal position.

- ▶ Use both hands to fold the folding part of the platform into the operating position.

Lifting the platform



- ▶ Turn the rotary switch **(3)** upwards and hold it until the platform has reached the vehicle bed.

The platform tilts into the horizontal or preset position and then lifts.

Lowering the platform



- ▶ Turn the rotary switch **(3)** downwards and hold it until the platform aligns with the ground.

After the platform has been set down on the ground, it tilts and aligns with the ground.

Folding the platform in



- ▶ Ensure that the platform is in the horizontal position on the ground.
- ▶ Wear gloves to protect your hands.
- ▶ Use both hands to fold the folding part of the platform out of the operating position and onto the fixed part of the platform.
- ▶ Turn the rotary switch **(2)** upwards and hold it in this position until the platform has reached the vertical position.

The platform swings out of the horizontal position into the vertical position.

- ▶ Wear gloves to protect your hands.
- ▶ Push the platform with both hands against the deflection roller.
- ▶ Turn the rotary switch **(3)** upwards and hold it in this position until the platform has reached the transport position.

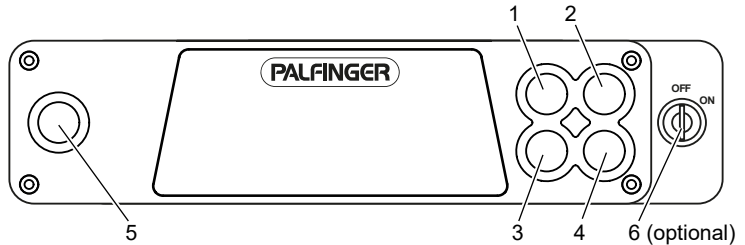
K 8.1.28. Operation via the Slimpanel

- 1 Function pushbutton 1
- 2 Function pushbutton 2
- 3 Function pushbutton 3
- 4 Function pushbutton 4
- 5 Additional pushbutton
- 6 optional: Key switch

DANGER!**Risk of accidents and injuries!**

When operating the tail lift, personal injury and damage to property may occur if you do not follow the instructions in the “General operation” chapter.

- ▶ First read the “General operation” chapter from page 33 before operating your tail lift.

Unfolding the platform

- ▶ Press and hold the additional pushbutton **(5)** and the function pushbutton **(3)** until the platform has reached the almost vertical position.

The platform lowers slightly and then swings over the deflection roller to almost the vertical position.

- ▶ Wear gloves to protect your hands.
- ▶ Pull the handle with both hands to unfold the platform backwards.
- ▶ Press and hold the additional pushbutton **(5)** and the function pushbutton **(4)** until the platform has reached the horizontal position.
- ▶ Use both hands to fold the folding part of the platform into the operating position.

Lowering the platform



- ▶ Press and hold the additional pushbutton **(5)** and the function pushbutton **(3)** until the platform aligns with the ground.

After the platform has been set down on the ground, it tilts and aligns with the ground.

Lifting the platform



- ▶ Press and hold the additional pushbutton **(5)** and the function pushbutton **(1)** until the platform has reached the loading position.

Folding the platform in



- ▶ Ensure that the platform is in the horizontal position on the ground.
- ▶ Wear gloves to protect your hands.
- ▶ Use both hands to fold the folding part of the platform out of the operating position and onto the fixed part of the platform.
- ▶ Press and hold the additional pushbutton **(5)** and the function pushbutton **(2)** until the platform has reached the vertical position.
- ▶ Push the platform with both hands against the deflection roller.
- ▶ Press and hold the additional pushbutton **(5)** and the function pushbutton **(1)** until the platform has reached the transport position.

L 8.1.29. Operation via the two hand control

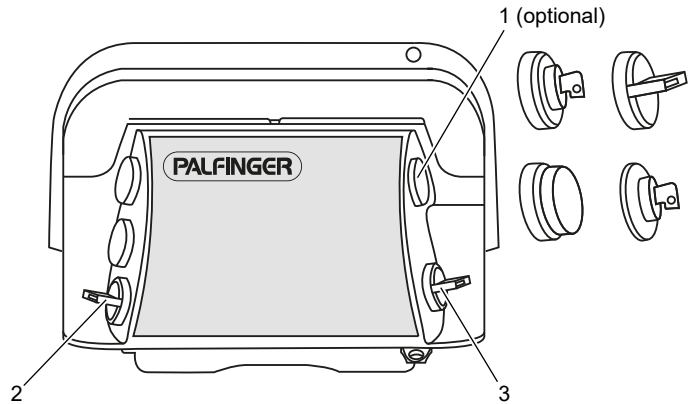

- 1 optional: Key switch, rotary switch, emergency stop button, E30 key
- 2 Rotary switch: Lift/lower
- 3 Rotary switch: Additional switch

DANGER!

Risk of accidents and injuries!

When operating the tail lift, personal injury and damage to property may occur if you do not follow the instructions in the "General operation" chapter.

- First read the "General operation" chapter from page 33 before operating your tail lift.



Note:

This manual describes the standard program. Special programs deviate from this description or have further functions. Our customer service department will provide you with a comprehensive description of your type.

Unfolding the platform



- ▶ Turn the rotary switches **(2)** and **(3)** downwards simultaneously and hold both until the platform has been set down on the ground.
- ▶ Wear gloves to protect your hands.
- ▶ Hold the platform edge with both hands to unfold the platform backwards.
- ▶ Pull the folding part of the platform with both hands to unfold it backwards.

Lifting the platform



- ▶ Turn the rotary switches **(2)** and **(3)** upwards simultaneously and hold both until the platform has reached the vehicle bed.

The platform tilts into the horizontal or preset position and then lifts.

Lowering the platform



- ▶ Turn the rotary switches **(2)** and **(3)** downwards simultaneously and hold both until the platform has been set down on the ground.

After the platform has been set down on the ground, it tilts and aligns with the ground.

Folding the platform in



- ▶ Ensure that the platform is in the horizontal position on the ground.
- ▶ Wear gloves to protect your hands.
- ▶ Use both hands to fold the folding part of the platform out of the operating position and onto the fixed part of the platform.
- ▶ Swing the platform to the roller on the stand tube.
- ▶ Turn the rotary switches **(2)** and **(3)** upwards simultaneously and hold both in this position until the platform is swung below the vehicle.

The platform raises and swings under the vehicle.

L 8.1.30. Operation via the one hand control

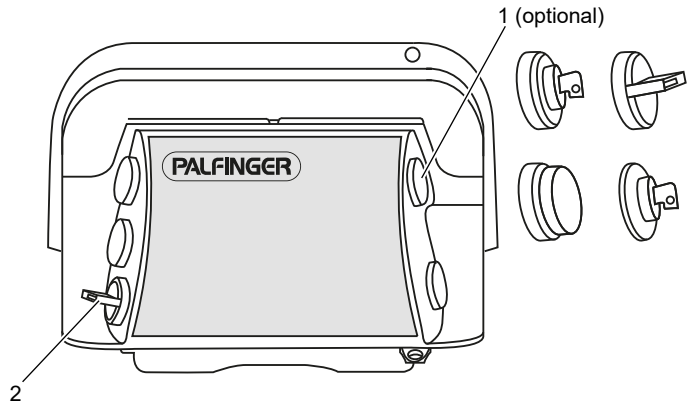

- 1 optional: Key switch, rotary switch, emergency stop button, E30 key
- 2 Rotary switch: Lift/lower



DANGER!

Risk of accidents and injuries!

When operating the tail lift, personal injury and damage to property may occur if you do not follow the instructions in the “General operation” chapter.

- ▶ First read the “General operation” chapter from page 33 before operating your tail lift.

Unfolding the platform



- ▶ Turn the rotary switch **(2)** downwards and hold it until the platform aligns with the ground.
- ▶ Wear gloves to protect your hands.
- ▶ Hold the platform edge with both hands to unfold the platform backwards.
- ▶ Pull the folding part of the platform with both hands to unfold it backwards.

Lifting the platform



- ▶ Turn the rotary switch **(2)** upwards and hold it until the platform has reached the vehicle bed.

The platform tilts into the horizontal or preset position and then lifts.

Lowering the platform



- ▶ Turn the rotary switch **(2)** downwards and hold it until the platform aligns with the ground.

After the platform has been set down on the ground, it tilts and aligns with the ground.

Folding the platform in



- ▶ Ensure that the platform is in the horizontal position on the ground.
- ▶ Wear gloves to protect your hands.
- ▶ Use both hands to fold the folding part of the platform out of the operating position and onto the fixed part of the platform.
- ▶ Swing the platform to the roller on the stand tube.
- ▶ Turn the rotary switch **(2)** upwards and hold it in this position until the platform is swung under the vehicle.

The platform raises and swings under the vehicle.

L 8.1.31. Operation via the Slimpanel

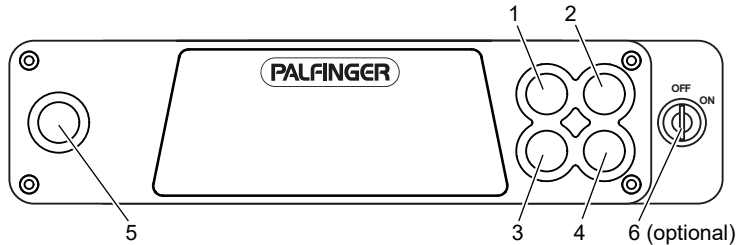

- 1 Function pushbutton 1
- 2 Function pushbutton 2
- 3 Function pushbutton 3
- 4 Function pushbutton 4
- 5 Additional pushbutton
- 6 optional: Key switch



DANGER!

Risk of accidents and injuries!

When operating the tail lift, personal injury and damage to property may occur if you do not follow the instructions in the “General operation” chapter.

- ▶ First read the “General operation” chapter from page 33 before operating your tail lift.

Unfolding the platform



- ▶ Press and hold the additional pushbutton **(5)** and the function pushbutton **(3)** until the torsion frame is touching the ground.
- ▶ Wear gloves to protect your hands.
- ▶ Hold the platform edge with both hands to unfold the platform backwards.
- ▶ Pull the folding part of the platform with both hands to unfold it backwards.

Lifting the platform



- ▶ Press and hold the additional pushbutton **(5)** and the function pushbutton **(1)** until the platform has reached the vehicle bed.

The platform tilts into the horizontal or preset position and then lifts.

Lowering the platform



- ▶ Press and hold the additional pushbutton **(5)** and the function pushbutton **(3)** until the platform aligns with the ground.

After the platform has been set down on the ground, it tilts and aligns with the ground.

Folding the platform in



- ▶ Ensure that the platform is in the horizontal position on the ground.
- ▶ Wear gloves to protect your hands.
- ▶ Pull the folding part of the platform with both hands to fold it in.
- ▶ Swing the platform to the roller on the stand tube.
- ▶ Press and hold the additional pushbutton **(5)** and the function pushbutton **(1)** until the platform is swung under the vehicle.

The platform raises and swings under the vehicle.

A C F G K L 8.2. Optional operating possibility: Foot control

Platform
with 2 foot controls
(standard)

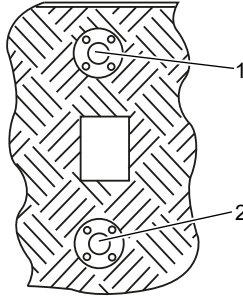

- 1 Foot control
(on the platform edge)
- 2 Foot control

Platform
with 3 foot controls
(controlled by the basic
board)

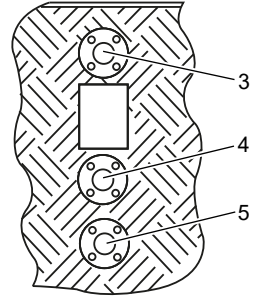

- 3 Additional foot control
(on the platform edge)
- 4 Foot control: lift
- 5 Foot control: lower

DANGER!

Risk of accidents and injuries!

When operating the tail lift, personal injury and damage to property may occur if you do not follow the instructions in the “General operation” chapter.

- ▶ First read the “General operation” chapter from page 33 before operating your tail lift.



8.2.1. Platform with 2 foot controls

Lowering the platform



- ▶ Step on the foot control (1) and hold it in this position.
- ▶ Step on the foot control (2) after one second at the earliest but no later than after three seconds and hold it in this position.

The platform lowers and aligns with the ground automatically.

Lifting the platform



- ▶ Step on the foot control **(2)** and hold it in this position.
- ▶ Step on the foot control **(1)** after one second at the earliest but no later than after three seconds and hold it in this position.

The platform first tilts into the horizontal position before lifting.

Note:

If you have not actuated both foot controls within three seconds, the foot controls are blocked for a short time. Wait a few seconds before repeating the process.

8.2.2. Platform with 3 foot controls

Lowering the platform



- ▶ Step on the foot control **(5)** and the additional foot control **(3)**.

The platform lowers and aligns with the ground automatically.

Lifting the platform



- ▶ Step on the foot control **(4)** and the additional foot control **(3)**.

The platform first tilts into the horizontal position before lifting.

8.3. Optional operating possibilities: Hand cable control and radio remote control



DANGER!

Danger due to platform tilting!

If the platform is tilted, there is a risk of the person on the platform falling due to slipping. The load can start to move and pose a risk of injuries. Damage to property is possible.

- ▶ Operating the tail lift from the platform is only permitted within the range of +/- 10 degrees from the platform horizontal.



WARNING!

Risk of crushing due to incorrect operating position!

When operating using the hand cable control or the radio remote control, if the operating person is standing in an incorrect location, this can cause injuries or damage to property if you do not follow the instructions below.

- ▶ Only operate the platform from the marked operating position (see the illustration below).
- ▶ If you are operating the platform from inside the vehicle structure, maintain a minimum distance of 250 mm to the loading edge.
- ▶ During operation, ensure that you never remain in the crushing edge area between the platform and the vehicle structure.
- ▶ Only stand on the area marked with footprints when operating on the platform.
- ▶ When operating the platform from the ground, maintain a minimum distance of 1 m to all platform edges.
- ▶ Ensure that you can view the entire working range clearly and that nobody remains close to the platform.

Operating position

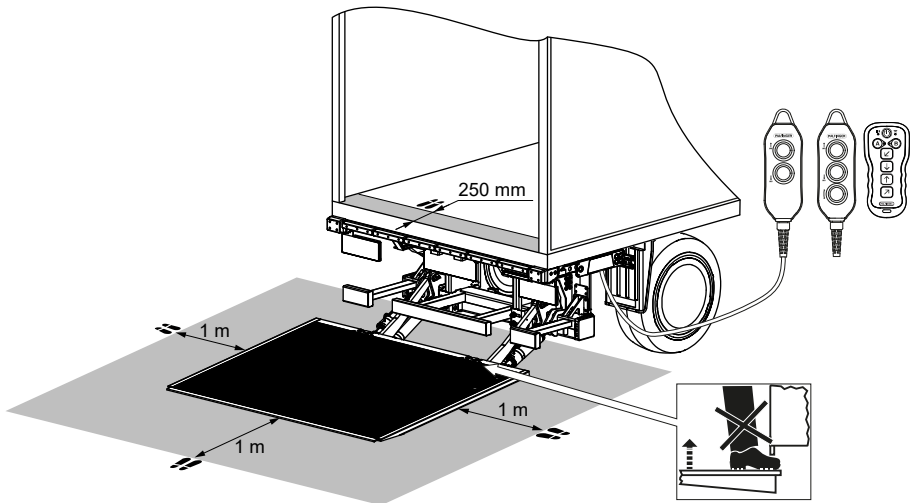

DANGER!

Risk of accidents and injuries!

When operating the tail lift, personal injury and damage to property may occur if you do not follow the instructions in the “General operation” chapter.

- ▶ First read the “General operation” chapter from page 33 before operating your tail lift.



A C F G K L

8.3.1. Hand cable control with two pushbuttons

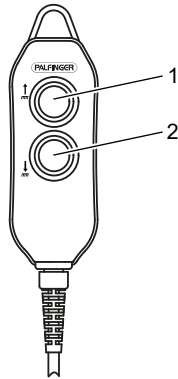

- 1 Pushbutton: Lift
- 2 Pushbutton: Lower

Note:

Observe installation instruction 89-558.00-00.00-01!

Lowering the platform

- ▶ Press the pushbutton **(2)** and hold it in this position until the platform aligns with the ground.

After the platform has been set down on the ground, it tilts and aligns with the ground.

Lifting the platform

- ▶ Press the pushbutton **(1)** and hold it in this position until the platform has reached the vehicle bed.

The platform tilts into the horizontal or preset position and then lifts.

8.3.2. Hand cable control with three pushbuttons

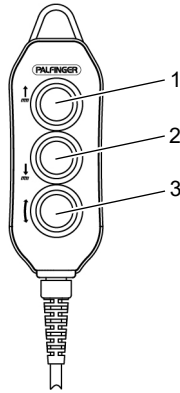

- 1 Pushbutton: Lift
- 2 Pushbutton: Lower
- 3 Pushbutton: Tilt

Note:

Observe installation instruction 89-558.00-00.00-01!

Lowering the platform



- ▶ Press the pushbutton **(2)** and hold it in this position until the platform aligns with the ground.

After the platform has been set down on the ground, it tilts and aligns with the ground.

Lifting the platform



- ▶ Press the pushbutton **(1)** and hold it in this position until the platform has reached the vehicle bed.

The platform tilts into the horizontal or preset position and then lifts.

Setting the platform to the horizontal position

- ▶ In order to set the platform tilt more steeply, press pushbuttons **(1)** and **(3)** simultaneously.
- ▶ In order to set the platform tilt flatter or to align the platform with the ground, press pushbuttons **(2)** and **(3)** simultaneously.

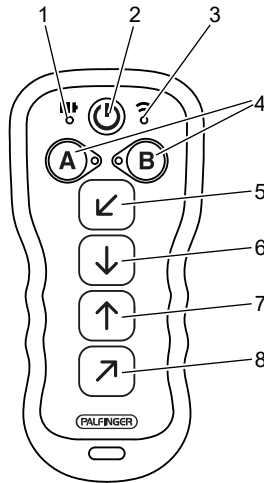
A C F G K L 8.3.3. Remote Control BT radio remote control

- 1 Battery LED
- 2 On/Off button
- 3 Status LED
- 4 Button: Special function
- 5 Button: Open
- 6 Button: Lower
- 7 Button: Lift
- 8 Button: Close

Note:

Observe installation instruction 07-500.99-09.01-99!

Note:

A comprehensive description of the radio remote control is provided in the manual in the packaging for the radio remote control.

Switching the radio remote control on/off

- ▶ Press the button **(2)** for two seconds to switch the radio remote control on.

After switching the radio remote control on successfully, the Battery LED **(1)** indicates the battery charge level (see the radio remote control manual).

- ▶ Press the button **(2)** to switch the radio remote control off.

The Battery LED **(1)** extinguishing indicates that the radio remote control is now switched off.

Opening the platform



- ▶ Press the button **(5)** and hold it in this position until the platform is open completely.

If optional load securing is present, the platform first lowers slightly and then folds into the horizontal operating position.

Lowering the platform



- ▶ Press the button **(6)** and hold it in this position until the platform aligns with the ground.

After the platform has been set down on the ground, it tilts and aligns with the ground.

Lifting the platform



- ▶ Press the button **(7)** and hold it in this position until the platform has reached the vehicle bed.

The platform tilts into the horizontal or preset position and then lifts.

Closing the platform



- ▶ Press the button **(8)** and hold it in this position until the platform is closed completely.

If optional load securing is present, the platform first only closes to around 80° and lowers slightly. It then moves into the vertical transport position and lifts into the load securing device.

Optional: Quick down



- ▶ Press the button **(6)** and hold it in this position until the platform aligns with the ground.



The platform opens and lowers simultaneously, and aligns with the ground.

ACKL 8.4. Special operating elements

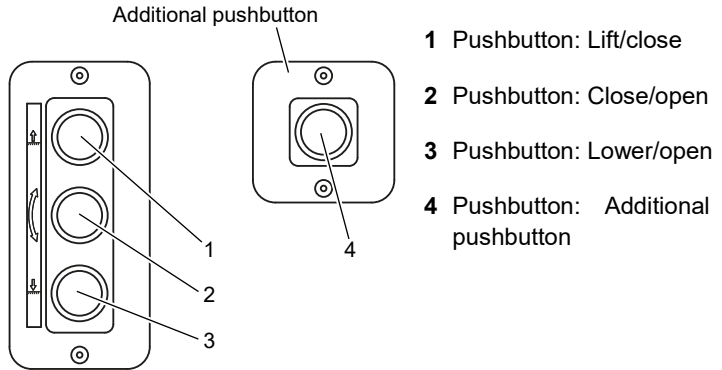

DANGER!

Risk of accidents and injuries!

When operating the tail lift, personal injury and damage to property may occur if you do not follow the instructions in the “General operation” chapter.

- ▶ First read the “General operation” chapter from page 33 before operating your tail lift.



Opening the platform



- ▶ Press the pushbuttons **(2)**, **(3)** and optionally **(4)** simultaneously until the platform is in the horizontal operating position.

Lowering the platform



- ▶ Press the pushbuttons **(3)** and optionally **(4)** simultaneously until the platform has aligned with the ground.

After the platform has been set down on the ground, it tilts and aligns with the ground.

Lifting the platform



- ▶ Press the pushbuttons **(1)** and optionally **(4)** simultaneously until the platform has reached the vehicle bed.

The platform first tilts into the horizontal or preset position before lifting.

Closing the platform



- ▶ Press the pushbuttons **(1)**, **(2)** and optionally **(4)** simultaneously until the platform has closed.

F G

8.5. Special operating elements

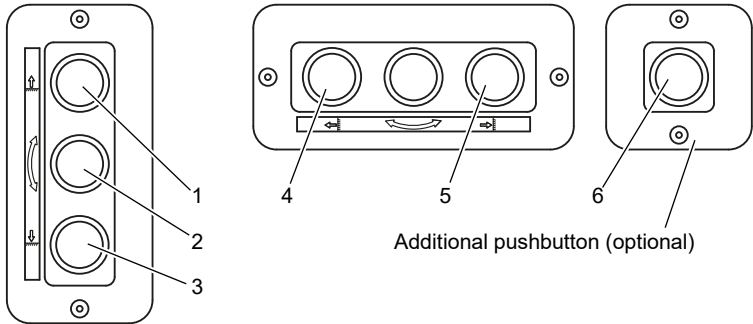

- 1** Pushbutton: Lift/close
- 2** Pushbutton: Close/open
- 3** Pushbutton: Lower/open

- 4** Pushbutton: Extend
- 5** Pushbutton: Retract
- 6** Pushbutton: Additional pushbutton

DANGER!

Risk of accidents and injuries!

When operating the tail lift, personal injury and damage to property may occur if you do not follow the instructions in the “General operation” chapter.

- ▶ First read the “General operation” chapter from page 33 before operating your tail lift.



Lowering the platform



- ▶ Press the pushbuttons **(3)** and optionally **(6)** simultaneously until the platform has aligned with the ground.

After the platform has been set down on the ground, it tilts and aligns with the ground.

Lifting the platform



- ▶ Press the pushbuttons **(1)** and optionally **(6)** simultaneously until the platform has reached the vehicle bed.

The platform first tilts into the horizontal or preset position before lifting.

Setting the platform to the horizontal position

- ▶ In order to set the platform tilt more steeply, press pushbuttons **(1)**, **(2)** and optionally **(6)** simultaneously until the platform has reached the required tilt.
- ▶ In order to set the platform tilt flatter, press the pushbuttons **(2)**, **(3)** and optionally **(6)** simultaneously until the platform has reached the required tilt.

Extending and unfolding the platform

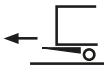

- ▶ Press the pushbuttons **(3)** and optionally **(6)** simultaneously until the platform has lowered.

The platform lowers in order to be able to extend without hindrances.



- ▶ Press the pushbutton **(4)** until the platform is extended completely.
- ▶ Press the pushbuttons **(3)** and optionally **(6)** simultaneously until the folded platform is set down on the ground.
- ▶ Wear gloves to protect your hands.
- ▶ Pull the handle with both hands to unfold the folding part of the platform.

Folding in and retracting the platform



- ▶ Wear gloves to protect your hands.
- ▶ Pull the handle with both hands to fold the folding part of the platform in.
- ▶ Press the pushbuttons **(1)** and optionally **(6)** simultaneously until the platform has reached the retraction height.
- ▶ Press the pushbutton **(5)** until the platform is retracted completely. Ensure that the platform can retract without hindrances.
- ▶ Press the pushbuttons **(1)** and optionally **(6)** simultaneously until the platform has reached the vibration safeguard.

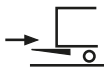

8.6. Special operating elements

A C K L

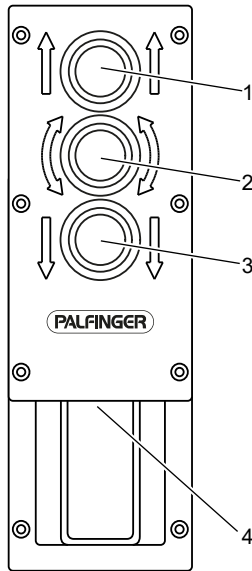

- 1 Pushbutton: Lift/close
- 2 Pushbutton: Close/open
- 3 Pushbutton: Lower/open
- 4 Pushbutton: Additional pushbutton

DANGER!

Risk of accidents and injuries!

When operating the tail lift, personal injury and damage to property may occur if you do not follow the instructions in the “General operation” chapter.

- ▶ First read the “General operation” chapter from page 33 before operating your tail lift.



Opening the platform



- ▶ Press the pushbuttons **(2)**, **(3)** and **(4)** simultaneously until the platform is in the horizontal operating position.

Lowering the platform



- ▶ Press the pushbuttons **(3)** and **(4)** simultaneously until the platform has aligned with the ground.

After the platform has been set down on the ground, it tilts and aligns with the ground.

Lifting the platform



- ▶ Press the pushbuttons **(1)** and **(4)** simultaneously until the platform has reached the vehicle bed.

The platform first tilts into the horizontal or preset position before lifting.

Closing the platform



- ▶ Press the pushbuttons **(1)**, **(2)** and **(4)** simultaneously until the platform has closed.

8.7. Special operating elements for hydraulic stabilizer feet

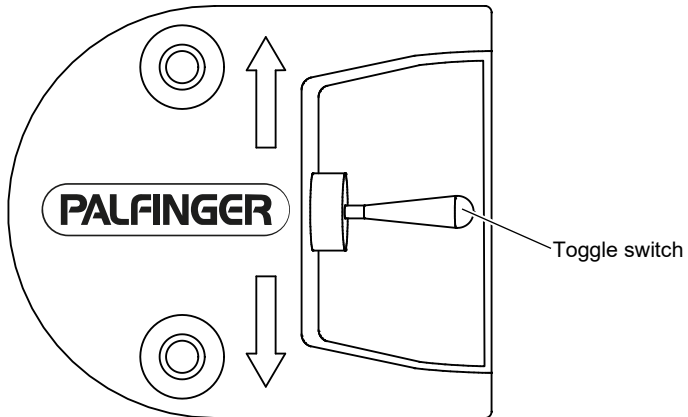

DANGER!

Risk of accidents and injuries!

When operating the tail lift, personal injury and damage to property may occur if you do not follow the instructions in the “General operation” chapter.

- ▶ First read the “General operation” chapter from page 33 before operating your tail lift.

Extending the hydraulic stabilizer feet

- ▶ Press the toggle switch downwards until the stabilizer feet are extended and touching the ground gently.

Retracting the hydraulic stabilizer feet

- ▶ Press the toggle switch upwards until the stabilizer feet are retracted completely.

Ambulance 8.8. Hand pump operation for C 1000 LX ambulance – C 1500 SX ambulance

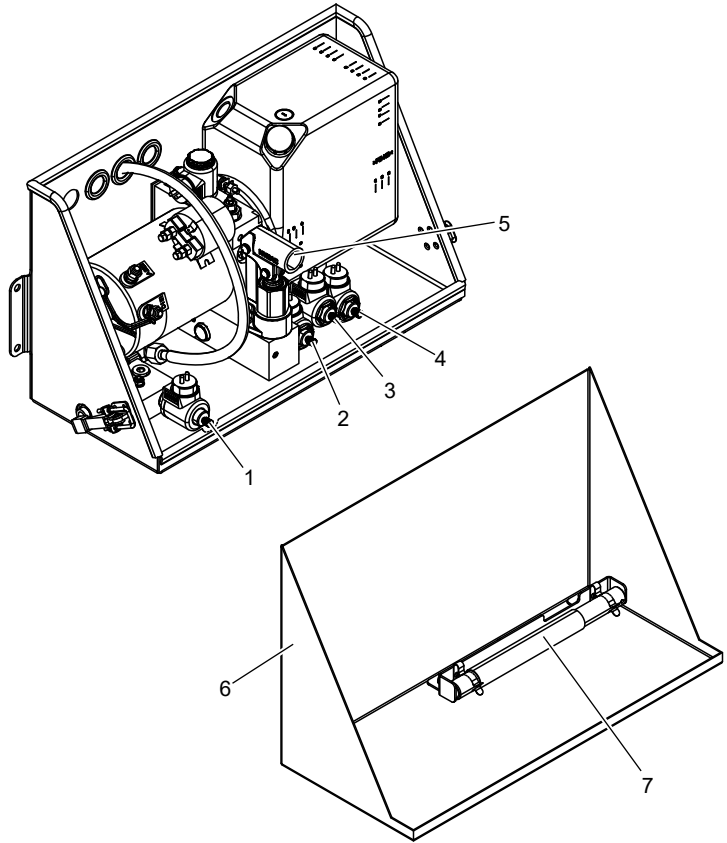

- | | |
|-----------------|---------------|
| 1 Valve S30 | 5 Pump device |
| 2 Valve S5 | 6 Unit cover |
| 3 Lifting valve | 7 Manual bar |
| 4 Tilt valve | |

Note:

All valves must be closed in order to operate in normal mode.

Opening the platform



- ▶ Loosen and remove the unit cover **(6)**.
- ▶ Open valve S30 **(1)** by turning the screw anticlockwise.
- ▶ Open the tilt valve **(4)** by turning the screw anticlockwise.
- ▶ Pull the platform out manually until it opens further due to gravity.
- ▶ Close the tilt valve **(4)** by turning the screw clockwise as soon as the platform has reached the required position.
- ▶ Close valve S30 **(1)** by turning the screw clockwise.

Lowering the platform



- ▶ Open valve S5 **(2)** by turning the screw anticlockwise.
- ▶ Open the lifting valve **(3)** by turning the screw anticlockwise.
- ▶ Close the lifting valve **(3)** by turning the screw clockwise to stop the lowering process.
- ▶ Close valve S5 **(2)** by turning the screw clockwise.

Lifting the platform



- ▶ Insert the hand bar **(7)** into the pump device **(5)**.
- ▶ Pump until the platform has reached the required position.

Closing the platform



- ▶ Open valve S5 **(2)** by turning the screw anticlockwise.
- ▶ Insert the hand bar **(7)** into the pump device **(5)**.
- ▶ Pump until the platform has reached the required position.
- ▶ Close valve S5 **(2)** by turning the screw clockwise.

9. Service and maintenance

DANGER!

Risk of injury and damage to property due to improperly performed maintenance work!

If maintenance work is performed improperly, numerous risks of injury and damage to property arise. These risks occur both during the maintenance work and as a result of improperly performed maintenance work.



- ▶ Maintenance work may only be performed by trained specialists.
- ▶ Never attempt to seal oil leaks with your hands.
- ▶ When performing maintenance work under the platform, secure the platform to prevent it lowering inadvertently.
- ▶ In the event of foldable and retractable platforms, there is a risk of injury due to tensioned screws moving suddenly. Relieve all springs.
- ▶ Only perform the maintenance work once this has been done.

CAUTION!

Risks of injury due to unexpected tail lift movements and due to short circuits!

If operating functions are triggered, the tail lift may move unexpectedly during maintenance work. Risks of injury due to impacts and crushing are the consequence.

The powerful batteries can cause burns in the event of short circuits.



- ▶ Use the battery main switch to disconnect the battery in advance or remove the earth strap from the battery.
- ▶ Only perform the maintenance work once this has been done.

9.1. Before maintenance

- ▶ Switch off the battery main switch or remove the earth strap.
- ▶ Secure or relieve springs before replacing.
- ▶ If hydraulic oil escapes, do not reach into the flow.
- ▶ When performing maintenance work under the platform, secure the platform to prevent it moving downwards.
- ▶ Use only original parts from **PALFINGER Tail Lifts** during maintenance work.
- ▶ Maintenance and repairs to the tail lift must be performed in a specialist service centre.

F G K L

9.2. Relieving springs

CAUTION!

Risks of injury due to tensioned springs!

One or several springs are installed in foldable platforms and the operator relieves these when operating the platform. When maintenance work is performed, these springs or parts of the platform may move unexpectedly. Risks of injury due to impacts and crushing may occur.



- ▶ Relieve any springs present.
- ▶ Only perform the maintenance work once this has been done.

To relieve the springs:

- ▶ Move the platform into a position in which the springs are relieved.
- ▶ Have a second person secure the platform or stabilizer feet in this position.

9.3. When disposing

- ▶ Dispose of oils and filters properly and in accordance with the applicable local regulations.

9.4. Maintenance intervals

Tasks	Daily	Depending on use	Monthly	Quarterly/ every six months	Annually	Every four years
Checking safety and warning equipment	X					
Checks during operation	X					
Cleaning the tail lift		X				
Checking the battery		X				
Checking/restoring platform markings		X				
When the vehicle is stopped: Checking the platform position			X			
Checking the bellows			X			
Checking the oil level			X			
Checking the screw connections and lines on the hydraulic system			X			
Checking that the bolts and nuts are tight			X			
Checking the weld seam on the head profile			X			
Moving the tail lift				X		
Lubricating the bearings on the tilt and lifting cylinders				X		
Lubricating the movement rails (only retractable tail lifts)					X	
Replacing the hydraulic oil					X	
Checking all weld seams					X	
Replacing all hydraulic hoses						X
Resetting the service counter (maintenance counter)		X				

9.5. Daily maintenance

9.5.1. Checking safety and warning equipment

The safety equipment on the tail lifts complies with the current version of the applicable regulations.

- ▶ Before starting your journey, ensure that all safety and warning equipment is functional.
- ▶ Replace or repair damaged or non-functioning safety and warning equipment.

Depending on the model, the safety and warning equipment comprises:

- Non-slip surface on the platform
- Roll bar on the platform (optional)
- Hand grip for the operator riding on the platform (not supplied as standard with the tail lift)
- Warning lights on the platform
- Warning flags behind the platform
- Platform lock on the platform (optional)
- Two-foot controller for “Lifting” and “Lowering” on the platform
- Key switch on the side controller or on the Slimpanel for trailers or semi-trailers
- Control unit with on and off switch in the lockable driver’s cab
- Visual signal in the driver’s cab when the tail lift is “ON” and the platform is open
- Shut-off valves on the lifting cylinders and tilt cylinders
- Flow valves to limit the lowering and opening speed

9.5.2. Checks during operation

- ▶ Pay attention to unusual noises and sudden tail lift movements during operation.

If unusual noises or sudden movements occur:

- ▶ Check whether there is a fault on the tail lift.
- ▶ Remedy any faults present immediately.

9.6. Maintenance depending on the usage frequency

9.6.1. Cleaning the tail lift



CAUTION!

Paint damage!

If you clean the tail lift with a pressure washer, paint damage can occur up to six weeks after painting.

- ▶ Only clean the tail lift with a pressure washer after at least six weeks following painting.

The following tail lift components are not permitted to be cleaned with a pressure washer:

- Piston rods and cylinder seals
- Controls
- Solenoid valves
- Foot control
- Warning lights and warning flags
- Bellows

Special procedure for cleaning galvanised and hot-dip galvanised surfaces

White discolourations can form on galvanised and hot-dip galvanised surfaces if they are cleaned improperly (white rust). Therefore:

- ▶ Only use a cold water jet (temperature below 50 °C) to clean galvanised or hot-dip galvanised surfaces during the first three months. Do not use any cleaning agents.
- ▶ After the first three months, use pH-neutral cleaning agents to clean galvanised or hot-dip galvanised surfaces.

Note:

White blooming on galvanised or hot-dip galvanised surfaces on new tail lifts during the winter months is normal. The do not affect the surface's quality and service life.

9.6.2. Checking the battery

- ▶ Maintain the battery in accordance with the vehicle manufacturer's specifications.

9.6.3. Checking the carbon brushes on the electric motor

CAUTION!

Risk of burns due to overheating electric motor!

Worn out carbon brushes can cause excessive power consumption. This can cause the electric motor to overheat.

- ▶ Check the carbon brushes on the electric motor in the hydraulic unit from time to time.
- ▶ Have worn out carbon brushes replaced.



9.6.4. Checking/restoring platform markings

The markings on the platform must always be clear. They indicate the payload centre of gravity and the operator's standing position when operating the tail lift using the hand cable control.

- ▶ Check that the markings are clear and use abrasion-resistant paint to restore them if required.

9.7. Monthly maintenance

9.7.1. When the vehicle is stopped: Checking the platform position

If the vehicle is not used for an extended period, the platform may lower due to design-related leakage rates on the shut-off valves.

- ▶ Check the platform position.
- ▶ Close the platform if it has lowered from the completely closed transport position.

9.7.2. Checking the bellows

- ▶ Ensure that both bellows are undamaged and that they are tight on the piston rod and the cylinder.
- ▶ Replace damaged bellows.

9.7.3. Checking the oil level

On a slide-in unit:

To check the oil level:

- ▶ Lower the tail lift so that it rests on the ground.
- ▶ If necessary, retract all stabilizer feet.
- ▶ Open the right cover of the stand tube.
- ▶ Loosen the fixing bolt of the hydraulic unit on the stand tube.
- ▶ Pull out the hydraulic unit until the control mark on the oil tank is visible.
- ▶ Check the indicator on the oil tank or dipstick to see whether the indicator is within the prescribed marked range.
- ▶ If necessary, top the oil level up to the marked area or to the max. marking.
- ▶ Slide the hydraulic unit back into the stand tube and fix it with the fixing screw.
- ▶ Close the right cover of the stand tube.

Note:

Retractable tail lifts must be retracted completely to check the oil level.

On a box, universal or reversible unit:

- ▶ Lower the tail lift so that it rests on the ground.
- ▶ If necessary, retract all stabilizer feet.
- ▶ Remove the unit cover.
- ▶ Check the indicator on the oil tank or dipstick to see whether the indicator is within the prescribed marked range.

- ▶ If necessary, fill the oil level up to the marked area.
- ▶ Re-attach the unit cover.

9.7.4. Checking the screw connections and lines on the hydraulic system

WARNING!

Risk of injury due to hydraulic oil escaping!

Oil can escape from damaged hoses and lines on the hydraulic system at high pressure and have a cutting effect. Injuries and poisoning are the consequence.



- ▶ Never attempt to seal oil leaks with your hands.
 - ▶ Take the tail lift out of service if there is a leak on the hydraulic system.
-
- ▶ Check that all screw connections on the hydraulic system are tight.
 - ▶ Check all hydraulic hoses for porosity and damage.
 - ▶ Check whether all hydraulic hoses are laid cleanly. There must not be any kinks or tears.
 - ▶ Re-tighten loose screw connections.
 - ▶ Replace damaged hydraulic hoses immediately.
 - ▶ Replace the hydraulic hoses after four years at the latest. The manufacturing date is embossed into the fittings.
-
- #### 9.7.5. Checking that the bolts and nuts are tight
- ▶ Check whether all bolts and nuts are tight.
 - ▶ Pay particular attention to all bearing pins and the corresponding bolts, and to all fasteners on the auxiliary frame and the tail lift fastening!
 - ▶ Re-tighten loose bolts and nuts.

9.7.6. Checking the weld seam on the head profile

- ▶ Check the top of the platform to see whether there is a crack on the weld seam on the head profile.

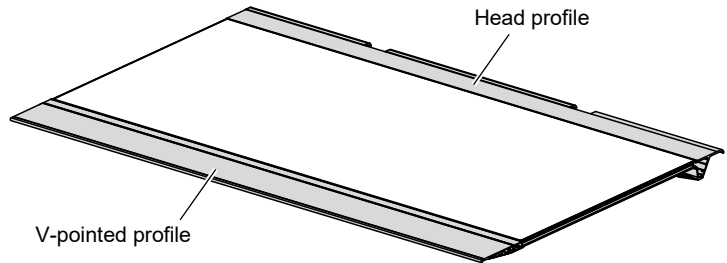

If there is a crack:

- ▶ Take the tail lift out of service.
- ▶ Have the damage rectified in an authorised workshop.

9.8. Quarterly maintenance or maintenance every six months

9.8.1. Moving the tail lift

In the event of downtimes of more than 3 months, you must move the tail lift several times.

- ▶ Open, lower, lift and close the tail lift.
- ▶ Repeat the procedure around 5 times.

9.8.2. Lubricating the bearings on the tilt and lifting cylinders

All bearings on the tilt and lifting cylinders must be lubricated once per quarter and following every cleaning procedure performed with a pressure washer.

For this purpose:

- ▶ Clean the tapered grease nipples on the bearings.
- ▶ Use a grease gun to press grease into the tapered grease nipples until the bearing points are filled (for the grease to be used, see chapter 15, page 194).

Note:

If you use the tail lift particularly frequently, you must lubricate the bearings more frequently.

F G**9.8.3. Lubricating the movement rails (only retractable tail lifts)**

The movement rails and the sliders on the movement rails must be lubricated every six months. The first lubrication should be performed one year after commissioning.

To lubricate the movement rails:

- ▶ Extend the platform completely.
- ▶ Use a spray lance to spray lubricating grease into the movement rails (for the grease to be used, see chapter 15, page 194).
- ▶ Retract the platform completely.
- ▶ Spray lubricating grease into the movement rails again.

Note:

If you use the tail lift particularly frequently, you must lubricate the movement rails more frequently.

9.9. Annual maintenance**9.9.1. Replacing the hydraulic oil****CAUTION!****Injuries or damage to property due to old oil!**

If you do not replace the oil in the hydraulic unit every year, condensation water can accumulate especially at temperatures below zero. This interrupts the tail lift's functions. People may get injured or property damaged.

- ▶ Replace the hydraulic oil once per year.
- ▶ Replace the oil shortly before the start of winter preferably.



Slide-in unit:

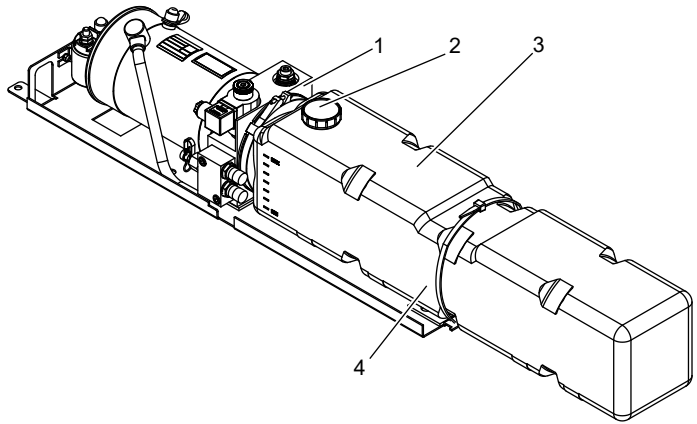

1 Valve block

2 Air filter

3 Hydraulic oil tank

4 Intake filter in the oil tank

Box-type unit:

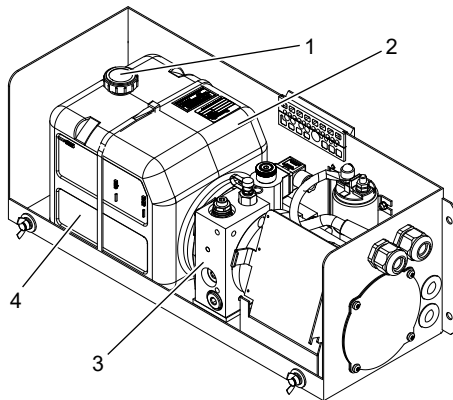

1 Air filter

2 Hydraulic oil tank

3 Valve block

4 Intake filter in the oil tank

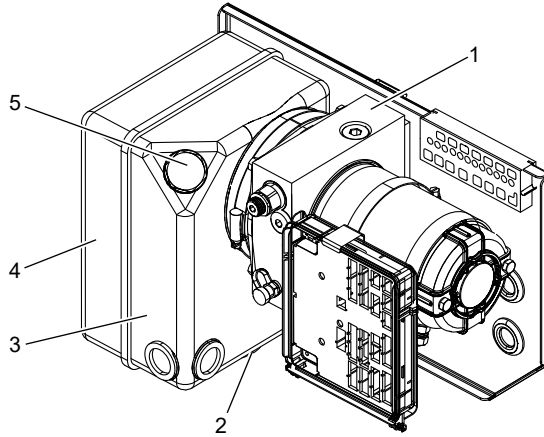
Universal unit:

1 Valve block

2 Oil drain screw

3 Intake filter in the oil tank

4 Hydraulic oil tank

5 Air filter

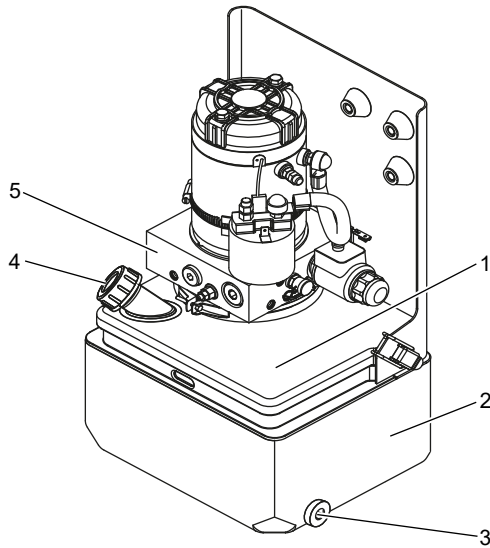
Reversible unit:

- | | |
|--|----------------------|
| 1 Intake filter in the oil tank | 4 Air filter |
| 2 Hydraulic oil tank | 5 Valve block |
| 3 Oil drain screw | |

To replace the hydraulic oil:

- ▶ Lower the tail lift so that the platform rests on the ground (see the “Operation” chapter from page 52).

On a slide-in unit:

- ▶ Pull the hydraulic unit out until the valve block protrudes completely (see the “Checking the oil level” chapter from page 141).

On a box, universal or reversible unit:

- ▶ Remove the unit cover.

If an oil drain screw is available:

- ▶ Place a sufficiently large container below the oil drain screw.
- ▶ Use a 6 mm Allen key to undo the oil drain screw and drain the oil into the container.

If no oil drain screw is available:

- ▶ Unscrew the air filter.

- ▶ Extract the hydraulic oil by suction.

If the hydraulic oil is heavily contaminated, you must clean the hydraulic oil tank:

- ▶ Loosen the clip between the hydraulic oil tank and the valve block.
- ▶ Pull the hydraulic oil tank out of the unit and clean it outside the hydraulic unit.
- ▶ Then replace the intake filter in the oil tank and the air filter.
- ▶ Slide the cleaned hydraulic tank back into the unit and re-insert the oil drain screw.
- ▶ Re-tighten the clip between the hydraulic oil tank and the valve block.
- ▶ Re-fill the oil to the marking on the oil tank or on the dipstick.

Note:

Only use oils that are listed in the “Lubricants and equipment” chapter from page 194.

- ▶ Run the system completely twice after filling the oil tank.
- ▶ Check the oil level (see the “Checking the oil level” chapter from page 141) and top up the oil or drain excess oil if necessary.

On a slide-in unit:

- ▶ Slide the hydraulic unit back into the stand tube and fasten it.

On a box, universal or reversible unit:

- ▶ Re-attach the unit cover.
- ▶ Dispose of the used oil properly and in accordance with the applicable local regulations.

9.9.2. Checking all weld seams

- ▶ Check all weld seams on the lifting mechanism and the platform for cracks and damage.

If cracks or other damage are present:

- ▶ Take the tail lift out of service.
- ▶ Have the damage rectified in an authorised workshop.

9.10. Maintenance every four years

9.10.1. Replacing all hydraulic hoses

- ▶ Drain the hydraulic oil.
- ▶ Replace all hydraulic hoses.
- ▶ Re-fill the oil to the marking on the oil tank or on the dipstick.

Note:

Only use oils that are listed in the “Lubricants and equipment” chapter from page 194.

- ▶ Run the system completely twice after filling the oil tank.

9.11. Resetting the service counter (maintenance counter)

Maintenance must be performed after lifting 5000 times. The control unit indicates that this limit has been reached by flashing at a high frequency for 2 seconds after switching on. Proceed as following to reset the service counter afterwards:

- ▶ Close the platform but leave the control unit switched on.
- ▶ Remove plug J 11.
- ▶ Remove plug J 30.
- ▶ Plug the service plug in.
- ▶ Plug in plug J 11.

The service counter has been reset.

- ▶ Remove the service plug again.
- ▶ Plug in plug J 30 again.
- ▶ Remove plug J 11 and plug it in again.

This switches the tail lift back into operating mode.

Note:

The service counter can also be reset using the diagnostic software.

10. Inspections

A control booklet is supplied with every tail lift. According to this control booklet, you must have the following inspections performed by a specialist at your authorised workshop:

- Inspection after assembly with a written confirmation of faultless commissioning in the control booklet.
- Regular subsequent inspections that must be performed at least once per year. The main scope of the inspections is described in the control booklet. The inspection must be confirmed in writing in the control booklet.
- Extraordinary inspection after significant repairs or changes to the design. The inspection must be confirmed in writing in the control booklet.

Note:

Structural modifications are only permitted with the manufacturer's approval. If modifications are made to the tail lift without our approval, all warranty claims are void. The manufacturer assumes no liability for damage, accidents, etc.

The same applies if using external spare parts if their use has not been approved explicitly by us.

11. Faults

Even a well cared for and maintained tail lift can experience faults.

The following description of possible faults that may occur provides you with the chance to detect faults quickly and to obtain time- and money-saving assistance.

A test lamp is preferable during troubleshooting. Use the earth connection provided on the board for troubleshooting.

11.1. Service partners

Troubleshooting and fault rectification should be performed by one of our service partners. The service partners are listed on our website at www.palfinger.com under "sales & service search".

11.2. Prior to troubleshooting

Check the following prior to troubleshooting:

- ▶ Ensure that the tail lift is switched on in the driver's cab.
- ▶ Check whether the battery main switch is switched on.
- ▶ Ensure that the main fuse for the power supply is OK.
- ▶ Check both control fuses on the hydraulic unit to ensure that they are functioning.
- ▶ Check the fuse for the control voltage on the vehicle's battery on 12-V systems to ensure that it is functioning.
- ▶ Ensure that the vehicle batteries work and are charged.
- ▶ Check whether the earth cable on the unit establishes a proper earth connection from the tail lift to the vehicle.
- ▶ Ensure that there is sufficient oil in the oil tank.
- ▶ Ensure that mechanical or electrical components such as cables are not damaged.



WARNING!

Risk of burns in the event of short circuits!

The powerful batteries can cause burns in the event of short circuits.

- ▶ Use the battery main switch to disconnect the battery prior to all work on the electrical system or remove the negative connection from the battery.

11.3. Troubleshooting

This function is only available for certain program versions. For more information, contact our customer service department. To perform troubleshooting:

- ▶ Switch the control unit on.
- ▶ Open the platform so that it is horizontal.
- ▶ Remove plug J 11.
- ▶ Remove plug J 30.
- ▶ Plug the service plug in.
- ▶ Plug in plug J 11.

The service plug must be plugged in for at least 12 seconds. "P" is then shown on the 7-segment display.

- ▶ Remove the service plug.
- ▶ Plug in plug J 30.

The Warnfix lights now illuminate each time a button or foot control is actuated. If your tail lift is not equipped with Warnfix, you must connect a test lamp to PIN 7, plug J3.

- ▶ Remove plug J 11 and plug it in again.

The tail lift switches back into operating mode.

Note:

Troubleshooting can also be performed using the diagnostic software.

11.4. Fault detection via the 7-segment display

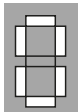
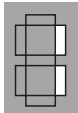

You can read the 7-segment display on the control board.

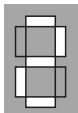
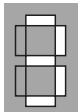
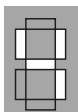
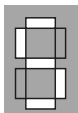
Status messages 7 segments, static, system LED flashes green (2 Hz)	
Status	Description, error reset by
	System switched on, system OK, control unit switched off
	System switched on, system OK, control unit switched on

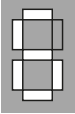
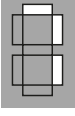
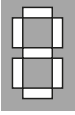
Error messages 7 segments, flashing (0.5 Hz), system LED flashes red (2 Hz)		
Status	Description	Error reset by
	Low voltage	Switch the control unit off/on
	On the control rod tilt switch (B13): On signal despite the platform being switched off -> Short circuit on B13	The error is reset automatically as soon as the correct values are reached again
	Control rod tilt sensor (B15): Incorrect sensor signal	
	Head tilt sensor (B15): Incorrect sensor signal	The error is reset automatically as soon as the correct values are reached again

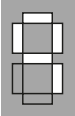
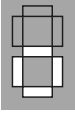
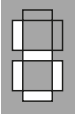
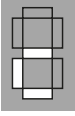
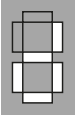
Error messages		
7 segments, flashing (0.5 Hz), system LED flashes red (2 Hz)		
Status	Description	Error reset by
	Warnfix: Short circuit detected	Switch the control unit off and back on or close the tail lift
	Case lighting/control unit LED: Short circuit detected	
	General short circuit error on the external system	Switch the control unit off/on or de-energise the board

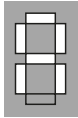
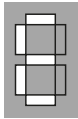
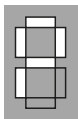
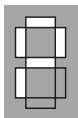
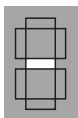
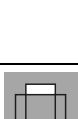
Valve coil monitor (not available on all models)		
Status	Description	Error reset by
	The “Motor relay coil resistance” error was detected when lifting	The error is reset automatically as soon as the correct values are reached again
	Not allocated or spare	
	When opening, the “Resistance, valve coil opening S3_S4” or “Motor relay resistance” error was detected	The error is reset automatically as soon as the correct values are reached again
	The “Motor relay resistance” or “S5” error was detected when lowering	
	When lowering, the “Resistance, valve coil lowering_S1_S2” error was detected	The error is reset automatically as soon as the correct values are reached again

Service functions (not available on all models)		
Status	Description	Deactivated by
	Voltage missing on J1/2 -> check the fuse.	The error is reset automatically as soon as voltage is present on J1/2.
	Emergency program, sensors are bypassed. Activate by pressing the "Open" and "Lower" buttons for more than 10 seconds.	Switch the control unit off/on
	Fault diagnostics on the inputs is active. Warnfix is activated each time a button is pressed.	
	Pairing mode is active for the radio remote control.	Automatic reset when connected or after one minute when not connected.
	The "Selflock" function is activated. The tail lift is blocked by radio receivers (e.g. ICP). Selflock = the control panel is locked automatically when leaving the vehicle	Resetting the "Selflock" function: Switch the control unit off and back on or place the radio transmitter close to the receiver again
	The interface is deactivated after a short circuit on plug JP (CAN).	De-energise the board for a few seconds
	Adjustment mode is activated. The platform angle can be changed.	Press a foot control 8 x or apply a positive pulse 8 x to plug J3, pin 6.

If the tail lift indicates further faults, do not rectify the faults yourself, but have them rectified by one of our service partners using the following tables.

11.5. Fault assistance tables

Before switching on		
Fault	Possible causes	Remedy
Visual indicator in the driver's cab flashes quickly	Tilt sensor B15 is faulty	Replace tilt sensor B15

Switching on (The LED on the board flashes in time with the indicator)		
Fault	Possible causes	Remedy
Visual indicator in the driver's cab flashes hectically	Tilt switch B13 is faulty (short circuit)	Replace tilt switch B13
	Control rod tilt sensor B15 is faulty	Replace tilt sensor B15
The LED on the board does not flash	The on switch in the driver's cab is faulty	Use a test lamp to test connection 2 and 4
	Fuses in unit e1 or e2 have tripped	Replace the fuses
The LED on the board does not flash	The board in the sealing cap is faulty	Replace the board

 Open (The platform opens to the horizontal operating position – this position is saved and moved to again when lifting after ground alignment)		
Fault	Possible causes	Remedy
The platform does not open with the motor	Output J 1/3 does not provide an output	Use a test lamp to test according to the circuit diagram
	The motor contactor is faulty	Check the motor contactor
The platform does not open	The rotary, pressure or toggle switch is faulty	Use a test lamp to test the contacts in the control according to the circuit diagram, use earth connection JK on the board

**Open**

(The platform opens to the horizontal operating position – this position is saved and moved to again when lifting after ground alignment)

Fault	Possible causes	Remedy
The platform does not open	The valve plug on S 3 or S 4 does not have any voltage, the cable is faulty	Use a test lamp to test
	Control valve S 5 or the pressure switch jams	Clean or replace
The warning lights on the platform do not flash when the platform is open	Tilt sensor B15 on the platform is misaligned or faulty	Adjust or replace
	The board is faulty	Replace
	The plugs are faulty	Replace
	The warning lights are faulty	Replace
	Proximity switch b25 is misaligned or faulty	Adjust or replace

**Extend**

Fault	Possible causes	Remedy
The platform does not extend, the motor is running	Solenoid valves S 7 and S 8 are leaking	Clean or replace
	Solenoid valve S 8 does not open	Clean or replace
The platform does not extend, the motor is running	Lowering brake valve S 11 does not open	Clean or replace
	The piston seal in the movement cylinder is faulty	Replace



Unfold

Model R 1500 SH – R 2000 LH

Fault	Possible causes	Remedy
The platform does not unfold, the motor is running	Solenoid valves S 7 and S 8 are leaking	Clean or replace
	Solenoid valve S 12 does not open	Clean or replace
	Valve S 10 does not open	Clean or replace
	The piston seal in the folding cylinder is faulty	Replace



Lower

Fault	Possible causes	Remedy
The platform does not lower or lowers too slowly but opening works	Flow valve R 1 or R 2 on the lifting cylinder is jammed or faulty	Clean or replace
	The bearing is too stiff	Lubricate the bearing points
	The hydraulic oil is too thick	Replace the oil. Use a recommended oil type
The platform does not lower when operating using the foot controls	You have pressed both foot controls too fast (less than 1 second) or too slowly (longer than 3 seconds) after each other	Release both foot controls, wait a few seconds, then repeat
The platform does not lower when operating using the foot controls	The foot control is faulty	Undo the plug connection on the platform. Use a continuity tester to test the foot control

 Lower		
Fault	Possible causes	Remedy
The platform does not lower when operating using the foot controls	Cable no. 2 to the platform is faulty	Press both foot controls and use the test lamp on plugs J 3/6 and J 3/5 on the board to test the voltage
The platform does not lower when operating using the side control	The rotary, pressure or toggle switch is faulty	Use a test lamp to test the contacts in the control according to the circuit diagram, use earth connection JK on the board
	The board does not provide an output at J 4/15	Remove plug J 4, use a test lamp to test terminal 12
	The board does not provide an output at J 1/12	Remove plug J 1, use a test lamp to test terminal 12
	The valve plug on S 1 or S 2 does not have any voltage (the cable is faulty)	Use a test lamp to test
	Valve S 5 in the unit does not switch on	Use a test lamp to test
The platform tilts down while lowering	Tilt switch B13 is misaligned	Adjust
The platform tilts down on its own	Solenoid valves S 3 and S 4 on the tilt cylinder are dirty or faulty	Clean or replace
	The piston seal in the tilt cylinder is faulty	Replace
The platform lowers automatically	Solenoid valves S 1 and S 2 on the lifting cylinder are dirty or faulty	Clean or replace



Ground alignment
(The platform tilts down)

Fault	Possible causes	Remedy
Emergency operation: see chapter 11.6, page 167		
The platform does not tilt down	Tilt switch B13 is misaligned or faulty	Move the platform to 250 mm above the ground, set the tilt switch to horizontal and secure
	Tilt switch B13 is faulty	Replace
	The board does not provide an output at J 4/14	Use a test lamp to test at connection bl (signal) on plug J 41 (tilt switch)
	The valve plug on S 3 or S 4 does not have any voltage (the cable is faulty)	Remove plug J 4, use a test lamp to test terminal 14
	Solenoid valves S 3 and S 4 on the tilt cylinder are dirty or faulty	Clean or replace
The platform does not tilt down	The board has saved an error	De-energise, use a test lamp to test
	Flow valve R 5 or the pressure switch is jammed or faulty	Clean or replace
	The board is faulty	Replace
The platform does not tilt down, the visual indicator in the driver's cab flashes quickly	Control rod tilt sensor B15 is faulty	Replace tilt sensor B15



Lifting the platform off the ground

(The platform tilts into the horizontal operating position that was saved when opening)

Fault	Possible causes	Remedy
The platform does not tilt into the horizontal operating position when operated using foot controls	You have pressed both foot controls too fast (less than 1 second) or too slowly (longer than 3 seconds) after each other	Release both foot controls, wait a few seconds, then repeat
	The foot control is faulty	Undo the plug connection on the platform. Use a continuity tester to test the foot control
	Cable no. 2 to the platform is faulty	Press both foot controls and use the test lamp on plugs J 3/6 and J 3/5 on the board to test the voltage
The platform does not tilt into the horizontal position when lifting	Directional valve S 5 is jammed or faulty	Clean or replace
	Tilt sensor B15 is faulty	Replace



Lifting the platform off the ground

(The platform tilts into the horizontal operating position that was saved when opening)

Fault	Possible causes	Remedy
The platform tilts beyond the pre-set position when lifting	Tilt sensor B15 is faulty	Replace
	Directional valve S 5 is jammed or faulty	Clean or replace
The platform does not tilt into the horizontal operating position, but lifts	The board does not provide an output at J 1/12	Use a test lamp to test terminal 12 on plug J 1, use earth connection JK on the board
	Valve S 5 in the unit does not switch on	Use a test lamp to test
The platform does not tilt into the horizontal operating position, but lifts, the visual indicator in the driver's cab flashes quickly	Platform tilt sensor B15 is faulty	Replace tilt sensor B15
The platform tilts beyond the pre-set position when you lift the platform	Tilt sensor B15 is faulty	Replace
	The directional valve is jammed or faulty	Clean or replace



Lift

(The platform lifts up to the loading edge)

Fault	Possible causes	Remedy
The platform does not lift	The rotary, pressure or toggle switch is faulty	Use a test lamp to test the contacts in the control according to the circuit diagram, use earth connection JK on the board

 Lift (The platform lifts up to the loading edge)		
Fault	Possible causes	Remedy
The platform does not lift	The board does not provide an output at J 1/3	Use a test lamp to test the board at plug J 1/3 according to the circuit diagram
	The motor contactor in the unit does not switch on or is faulty	Use a test lamp to test the motor contactor
The platform does not lift even though the hydraulic unit is running	Directional valve S 5 is jammed or faulty	Clean or replace
	Solenoid valves S 1 and S 2 on the lifting cylinder are dirty or faulty	Clean or replace
	The suction filter on the pump is contaminated	Clean or replace
	The platform is overloaded	Reduce the load in accordance with the load table
	The hydraulic pump is faulty	Replace
	The electric motor is faulty	Replace
	The pressure switch is contaminated or faulty	Clean or replace
	The pressure relief valve is misaligned or faulty	First re-adjust and then seal or replace

 Close (The platform closes)		
Fault	Possible causes	Remedy
The platform does not close	The rotary, pressure or toggle switch is faulty	Use a test lamp to test the contacts in the control according to the circuit diagram, use earth connection JK on the board
The platform does not close	The board does not provide an output at J 1/3 or J 1/12	Use a test lamp to test the board at plug J 1/3 or J 1/12 according to the circuit diagram
	The motor contactor or valve S 5 in the unit does not switch on	Use a test lamp to test
The platform is at the closed limit position but not at the vehicle bed height	The structure end was not reinforced sufficiently when installing	Reinforce the structure according to the specifications in the installation drawing
	The bearing is worn out (if used for a long time)	Replace the bearing pins and bearing bushes

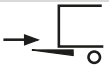
 Retract		
Fault	Possible causes	Remedy
The platform does not retract, the motor is running	Solenoid valves S 7 and S 8 are leaking	Clean or replace
	Solenoid valve S 7 does not open	Clean or replace
	Solenoid valve S 11 does not open	Clean or replace
	The piston seal in the movement cylinder is faulty	Replace

**Fold**

(on model R 1500 SH – R 2000 LH)

Fault	Possible causes	Remedy
The platform does not fold, the motor is running	Solenoid valves S 7 and S 8 are leaking	Clean or replace
The platform does not fold, the motor is running	Solenoid valve S 12 does not open	Clean or replace
	Solenoid valve S 9 does not open	Clean or replace
	The piston seal in the folding cylinder is faulty	Replace

Switching Warnfix on

(Warnfix is switched on automatically when opening or extending the platform, the left and right warning lights are switched in parallel)

Fault	Possible causes	Remedy
The warning lights do not flash	Short circuit on the warning light or cabling	Rectify the short circuit
	The warning light is faulty	Replace
	Proximity switch B25 is faulty	Replace

11.6. Emergency operation

If the tail lift can no longer be operated due to a faulty sensor, it can be switched into emergency operation. The sensors are not queried in emergency operation. Proceed as following to switch to emergency operation:

When operating using the one or two hand control:

- ▶ Actuate the “Open”, “Lower” and, if present, “Additional switch” rotary switches simultaneously for at least 10 seconds.

When operating via the Slimpanel:

- ▶ Press the additional pushbutton and any three function pushbuttons simultaneously for at least 10 seconds.

An “E” is displayed on the 7-segment display. Each tail lift movement must now be made manually. All automatic processes are deactivated.

CAUTION!

Risk of damage to property in emergency operation!

All tail lift sensors are deactivated in emergency operation. The tail lift can move beyond the set limit positions. The tail lift and the vehicle may get damaged.



- ▶ Monitor the tail lift movements precisely during emergency operation.
- ▶ Release the controls once the tail lift reaches an intended position.

11.7. Emergency operation: Closing the platform if all controls fail

If the tail lift cannot be controlled using the controls even in emergency operation, the platform can be closed by actuating the motor contactor and valve S5 directly on the hydraulic unit. This enables the vehicle's roadworthiness to be restored.

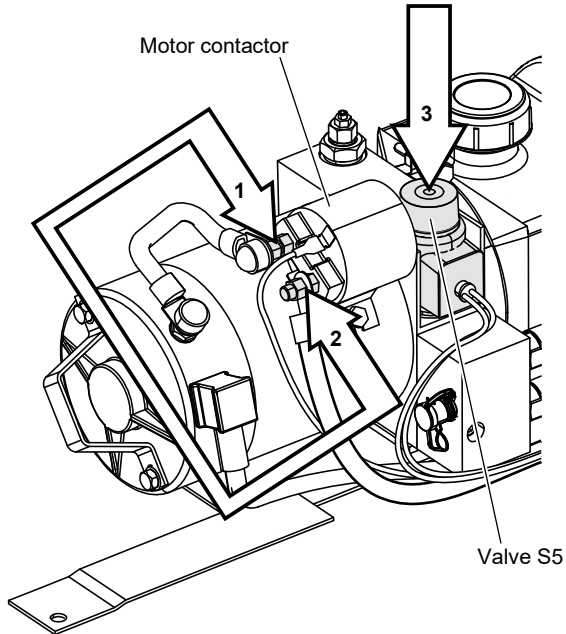

On a slide-in unit:

- ▶ Open the right cover of the stand tube.
- ▶ Loosen the fixing bolt of the hydraulic unit on the stand tube.
- ▶ Pull the hydraulic unit out until the motor contactor and valve S5 are accessible.

On a box, universal or reversible unit:

- ▶ Loosen and remove the unit cover.

Lifting the platform



- ▶ Bypass contacts **1** and **2** on the motor contactor until the platform has reached the vehicle bed height.

Closing the platform



- ▶ Bypass contacts **1** and **2** on the motor contactor. Actuate valve S5 at the same time by pressing it in (**3**), e.g. using a screwdriver.

On a slide-in unit:

- ▶ Slide the hydraulic unit back into the stand tube and fix it with the fixing screw.
- ▶ Close the right cover of the stand tube.

On a box, universal or reversible unit:

- ▶ Put the unit cover back on and secure it.

11.8. Emergency platform opening in the event of a fault

In an emergency, the platform can be opened by knocking the top tilt cylinder pin out if the controller fails completely.

DANGER!

Risk of serious to fatal injuries due to the platform tilting down!

If the hydraulic tilt cylinder bolts are knocked out, the platform tilts down if it is not secured. The platform can weigh significantly more than 100 kg and cause serious injuries when it tilts down. There is a danger of death! The platform can only be secured using a forklift or a suitable fire fighting appliance. Only perform emergency opening if it is available.

The hydraulic tilt cylinders also tilt down if the pins are knocked out and can cause injuries.

Damage to the platform and the tilting cylinders may occur.

- ▶ Only perform emergency opening in a serious emergency (e.g. a fire in the freight space).
- ▶ Secure the platform with a forklift or a suitable fire fighting appliance to prevent it tilting down.
- ▶ Secure the hydraulic tilt cylinders to prevent them tilting down.
- ▶ Only perform emergency platform opening once this has been done.



In order to perform emergency platform opening:

- ▶ Secure the platform with a forklift or a suitable fire fighting appliance to prevent it tilting down.
- ▶ Secure the hydraulic tilt cylinders to prevent them tilting down.

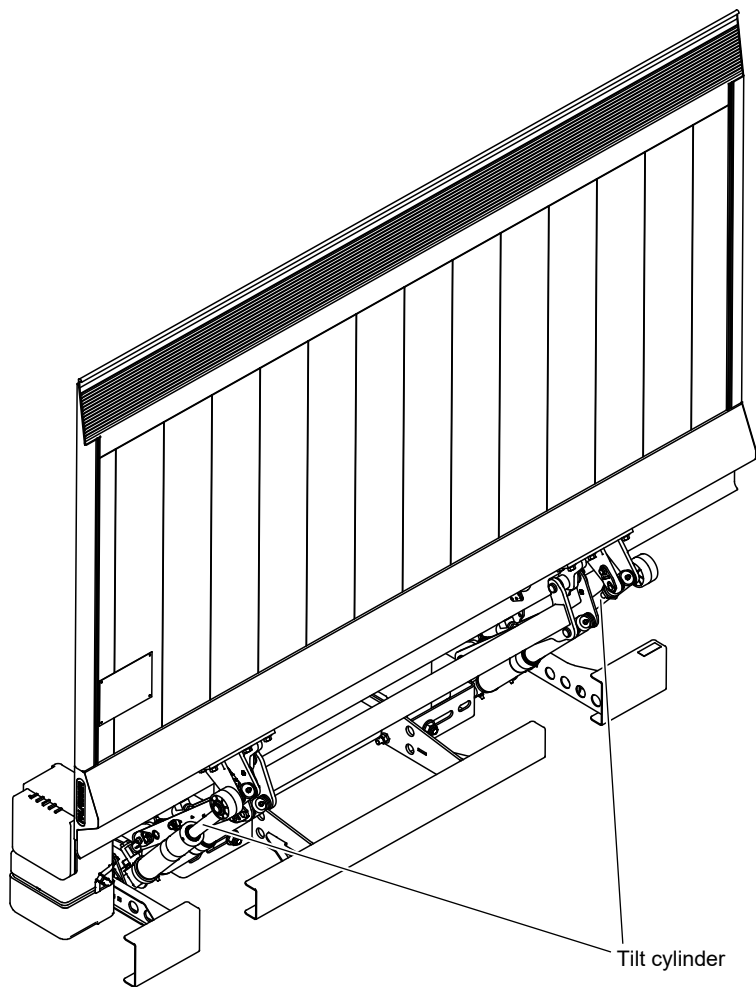

- ▶ Undo and remove the screws that are used to secure the locking straps to the top pin holders on both hydraulic tilt cylinders.

- ▶ Remove the locking straps.

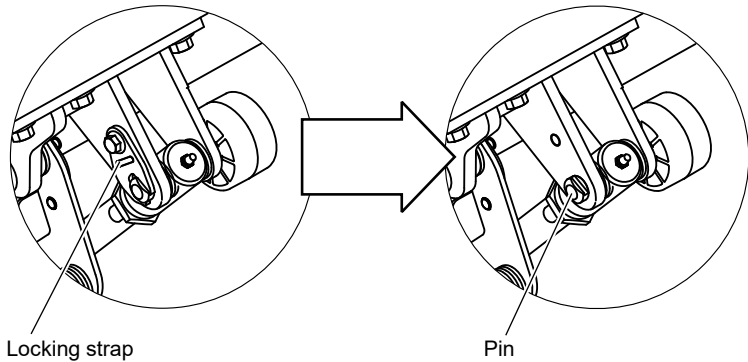

- ▶ Knock the pins out.
- ▶ Lower the hydraulic tilt cylinder.
- ▶ Use the forklift or suitable fire fighting appliance to tilt the platform down slowly.

Closing the platform after emergency opening

- ▶ Use the forklift or suitable fire fighting appliance to lift the platform into the closed, vertical position. Ensure that the platform cannot tilt down unexpectedly.
- ▶ Move the hydraulic tilt cylinders into their operating position.
- ▶ Pin the hydraulic tilt cylinders to the platform.
- ▶ Place the locking straps onto the pins and use a hammer to knock them in properly.
- ▶ Turn the locking straps to the screw-on position.
- ▶ Screw the locking straps on again. Use new screws with locking varnish. Tighten the screws to a torque of 75 Nm.

12. Technical data

12.1. Recommended battery capacity

Load weight [kg]	Recommended battery capacity
up to 1250	12 V = 1 x 143 Ah 24/12 V, 24 V = 2 x 12 V, 2 x 105 Ah
from 1250 to 1750	12 V = 1 x 180 Ah 24/12 V, 24 V = 2 x 12 V, 2 x 143 Ah
from 1750 to 4000	24/12 V, 24 V = 2 x 12 V, 2 x 180 Ah

Note:

If you only drive your vehicle for short distances, i.e. city traffic with frequent loading operations, select a battery with the next highest level. We also recommend that you use a stronger alternator.

12.2. Alternators to recharge the battery

Load weight [kg]	Recommended alternator [watt]
up to 1250	630
from 1250 to 1750	730
from 1750 to 4000	1000

12.3. Temperature range for using the tail lift

Standard	Special "cold" configuration
-20 °C to +60 °C	-40 °C to +60 °C

13. Load diagrams

The following tables show how heavy the payload (**Q**) is permitted to be. The load table that is valid for your tail lift is also provided on the side control.

The payload (**Q**) comprises everything that is on the platform, e.g. the goods being transported, the operator and any industrial trucks.

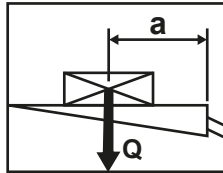

The maximum permissible payload (**Q**) depends on the load distance (**a**). The load distance (**a**) is the distance between the rear edge of the loading surface and the payload centre of gravity (**S**).

The maximum permissible payload (**Q**) for the corresponding maximum permissible load distance (**a**) is marked permanently by markings on the platform surface.

DANGER!**Risk of injuries and damage to property!**

If you exceed the maximum permissible payload (**Q**) or the maximum permissible load distance (**a**), the tail lift can fall down! This could cause people to be injured and serious damage to the tail lift. All warranty claims are invalid in this case!

If you position the payload (**Q**) in the middle between the left and right platform edge:

- ▶ Load the tail lift with no more than the payload (**Q**) specified in the table along with the corresponding load distance (**a**)!

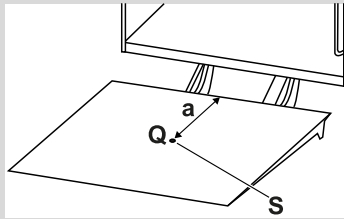

If you position the payload (**Q**) at the left or right platform edge:

- ▶ Load the tail lift with no more than half of the payload (**Q**) specified in the table along with the corresponding load distance (**a**).

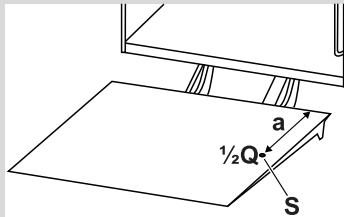

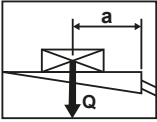
A 13.1. Standard tail lifts

	(a) mm	Q (kg)		(a) mm	Q (kg)
C 750 S	600	750	C 1750 LD	850	1750
C 750 L	700	650	C 1750 SZD	1000	1450
C 750 LX	820	550		1300	1150
C 750 SPL	1120	400		1650	900
C 750 SPR	1800	250		2400	600
PTC 750 L					
PTC 750 LLW					
C 1000 L	600	1000	C 2000 L	750	2000
C 1000 SPL	750	800	C 2000 LZ	900	1650
C 1000 SPR	950	600	C 2000 LK	1100	1300
C 1000 ML	1400	400	C 2000 LX	1600	950
C 1000 ML PRO	2400	230		2400	600
PTC 1000 LLW					
C 1000 S	700	1000	C 2000 S	1000	2000
	875	800	C 2000 SK	1200	1650
	1150	600		1500	1350
	1700	400		1800	1100
	2400	250		2100	950
C 1000 LD	900	1000	C 2500 L	750	2500
	1120	800		900	2050
	1500	600		1100	1700
	2250	400		1600	1150
	2400	375		2400	750
C 1500 L	600	1500	C 2500 S	1000	2500
C 1500 LX	720	1250	C 2500 SK	1400	1785
C 1500 ML	900	1000	C 2500 SZ	1600	1560
	1200	750		1800	1385
	2400	370		2400	1040

	(a) mm	Q (kg)		(a) mm	Q (kg)
C 1500 S	1000	1500	C 3000 S	1000	3000
C 1500 SZ	1200	1250		1200	2000
C 1500 SK	1500	1000		1500	1600
	1850	800		1800	1300
	2400	600		2400	1000

C 13.2. Standard tail lifts – van models

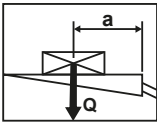

	(a) mm	Q (kg)		(a) mm	Q (kg)
C 350 VAN	850	350	C 500 VAN	600	500
	1000	300	C 500 VAN FLEX	700	430
	1200	250		820	360
	1500	200		1120	260
	1800	160		1800	160

	(a) mm	Q (kg)
C 600 VAN	600	600
	700	430
	820	360
	1120	260
	1600	160

**F 13.3. Retractable tail lifts
Single-folding platform**

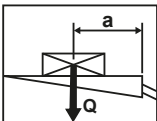

	(a) mm	Q (kg)		(a) mm	Q (kg)
R 750 L	600	750	R 1500 S	1000	1500
	700	650	R 1500 SK	1200	1250
	820	550	R 1500 S TRAIL	1500	1000
	1120	400	R 1500 S TRUCK	1850	800
	1800	250		2400	600

	(a) mm	Q (kg)		(a) mm	Q (kg)
R 1000 S	700	1000	R 2000 L	750	2000
R 1000 S TRUCK	875	800	R 2000 LK	900	1650
	1150	600	R 2000 L TRAIL	1100	1300
	1700	400	R 2000 L TRUCK	1600	950
	2400	250		2400	600
R 1000 S TRUCK LGD / CCK	800	1000	R 2000 S	1000	2000
	950	840		1200	1650
	1100	725		1500	1350
	1250	640		1800	1100
	1400	570		2100	950
R 1500 L	600	1500	R 2500 L	750	2500
R 1500 L FLAT	720	1250	R 2500 L TRAIL	900	2050
R 1500 LX FLAT	900	1000		100	1700
	1200	750		1600	1150
	2400	370		2400	750
R 1500 L TRUCK LGD / CCD	700	1500	R 2500 S	1000	2500
	850	1235		1400	1785
	1000	1050		1600	1560
	1150	900		1800	1385
	1300	800		2400	1040

G 13.4. Retractable tail lifts
Double-folding platform

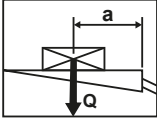

	(a) mm	Q (kg)		(a) mm	Q (kg)	
R 750 SM	600	750	R 1500 SM	1000	1500	
	700	650		R 1500 SH	1200	1250
	820	550			1500	1000
	1120	400			1850	800
	1800	250			2400	600
R 1000 LM	600	1000	R 2000 LM		750	2000
	750	800		R 2000 LH	900	1650
	950	600			1100	1300
	1400	400			1600	950
	2400	230			2400	600

K 13.5. Foldable tail lifts
Four-cylinder models

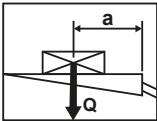

	(a) mm	Q (kg)		(a) mm	Q (kg)
F 1000 SH F 1000 SX	600	1000	F 2000 LH F 2000 LX	750	2000
	750	800		900	1650
	1000	600		1100	1300
	1500	400		1600	950
	2400	250		2400	600
F 1500 LH F 1500 LX	600	1500			
	720	1250			
	900	1000			
	1200	750			
	2400	370			

L 13.6. Foldable tail lifts
Two-cylinder models

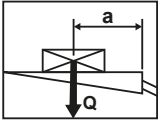

	(a) mm	Q (kg)
F 1000 L	600	750
	700	650
	820	550
	1120	400
	1800	250
F 1000 LD	650	1000
	850	800
	1150	600
	1700	400
	2400	250

	(a) mm	Q (kg)
F 1250 S	550	1250
	650	1000
	900	7500
	1350	500
	2400	250
F 1500 L	600	1500
	720	1250
	900	1000
	1200	750
	2400	370

14. Hydraulic circuit diagrams

A K 14.1. Standard tail lift with four cylinders

96-560.98-00.00-00

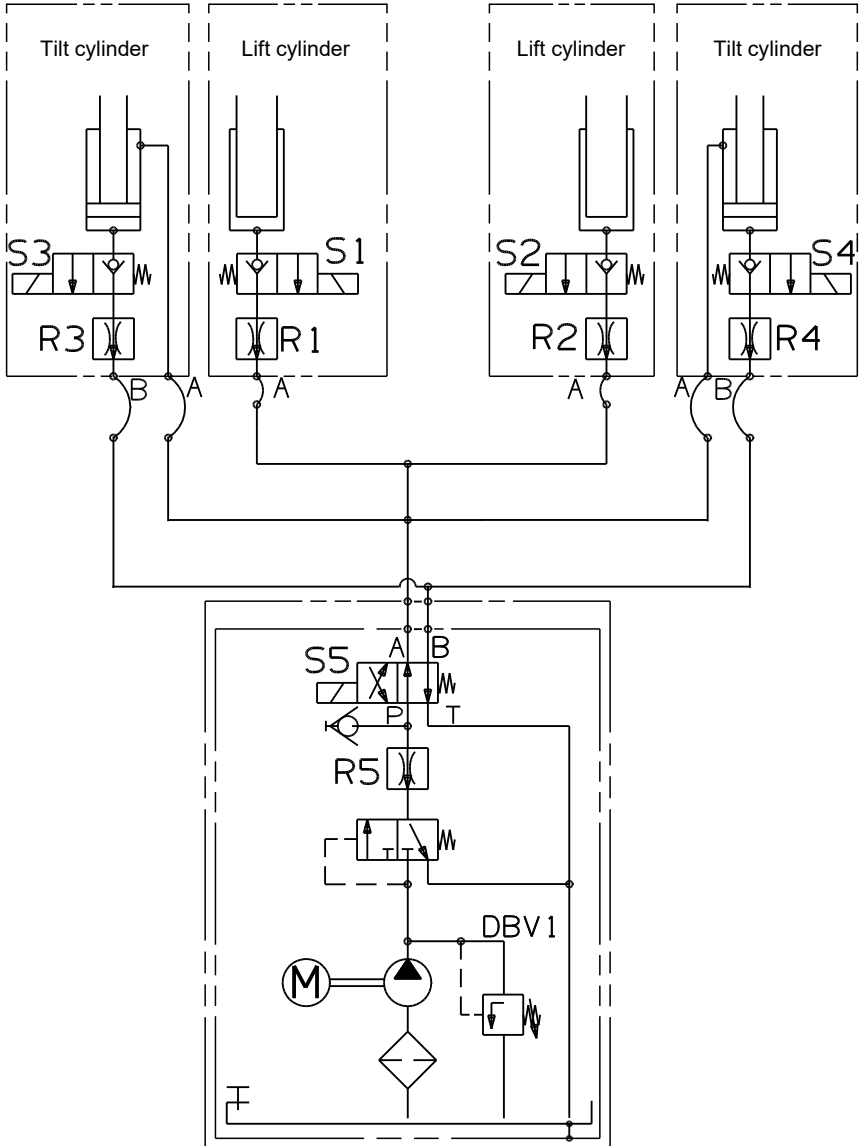

A 14.2. Standard tail lift with soft levelling

18-587.98-01.00-03

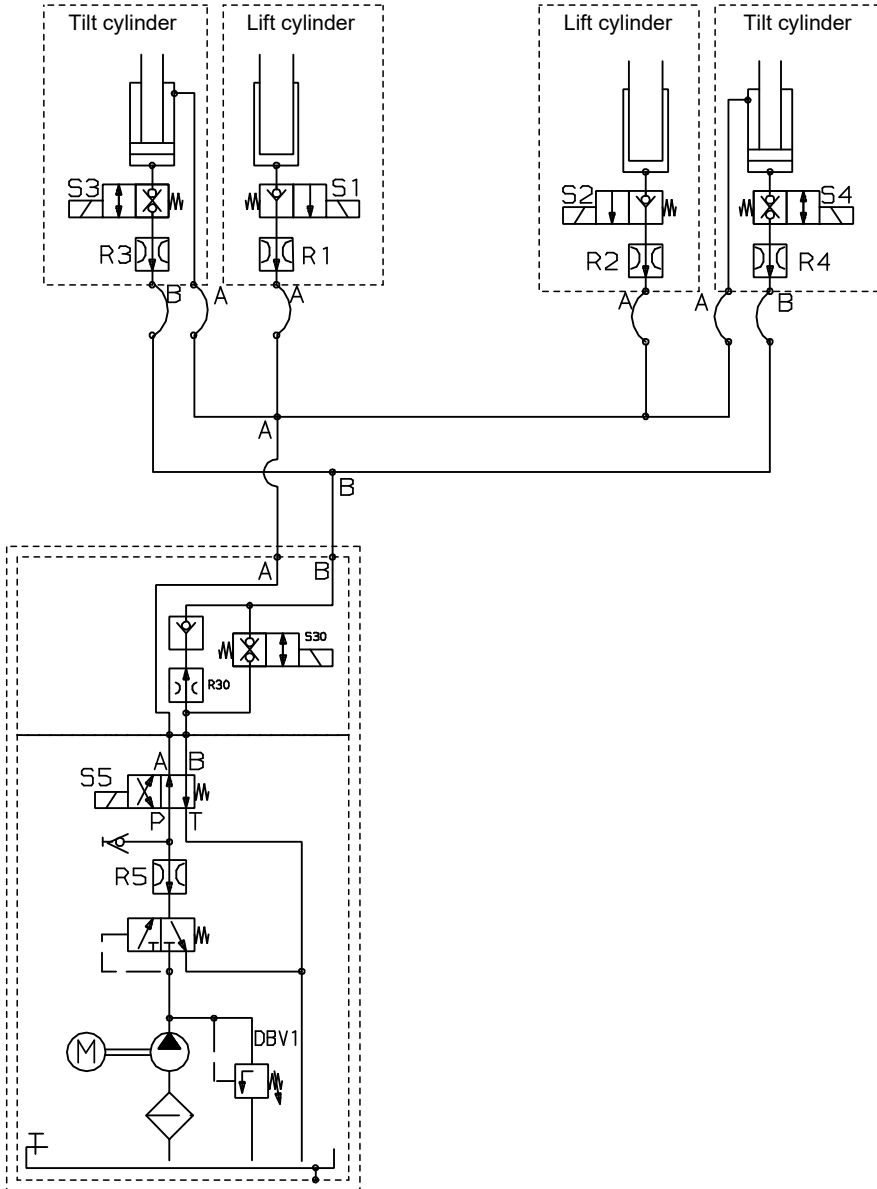

A C 14.3. Standard tail lift with two cylinders

97-510.98-00.00-00

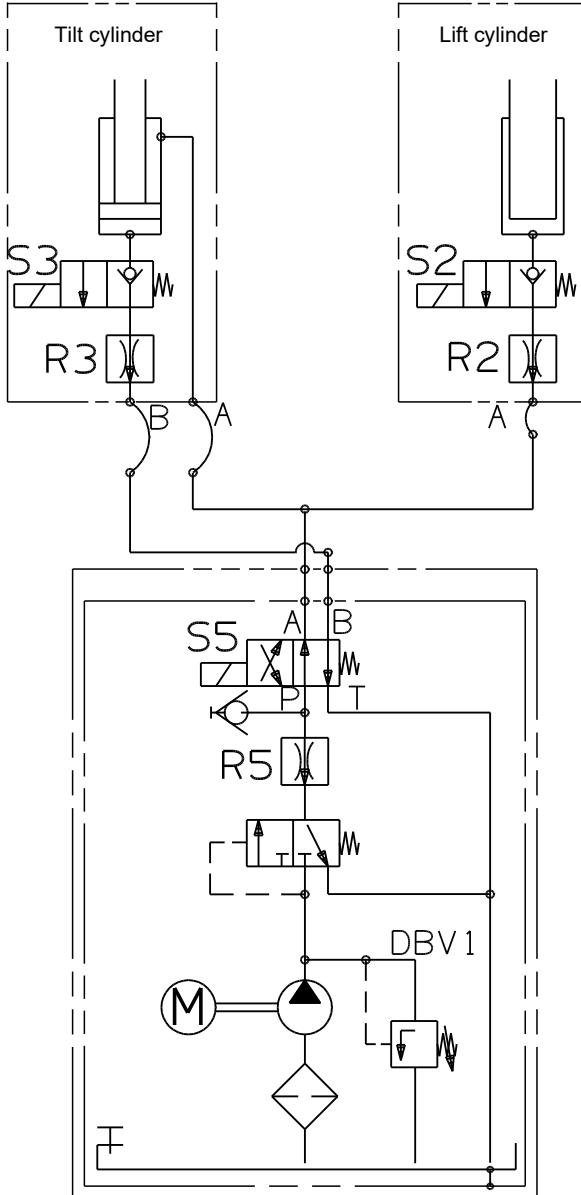

A 14.4. Standard tail lift with hydraulic stabilizer feet

96-524.98-01.00-00

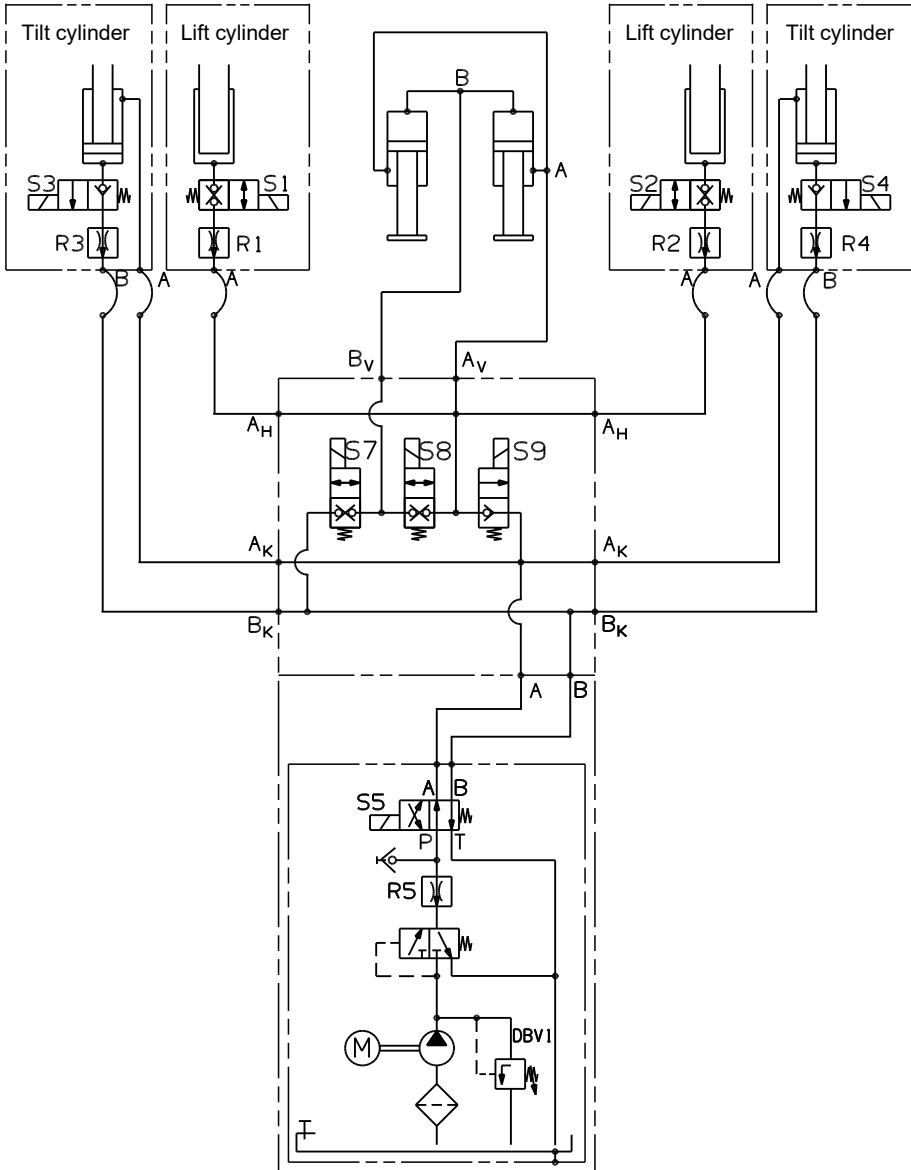

A 14.5. Tail lifts with hydraulic stabilizer feet C 750 L

12-530.98-01.00-00

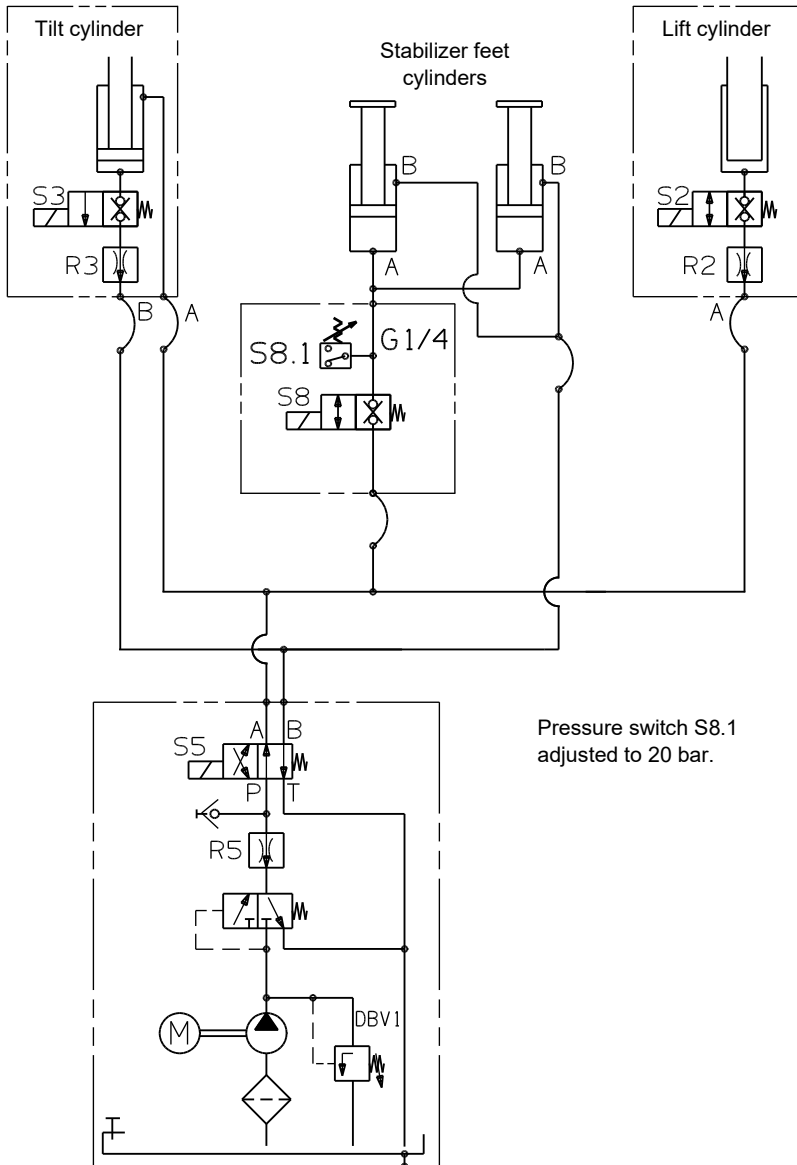

Pressure switch S8.1
adjusted to 20 bar.

A 14.6. Tail lifts with hydraulic stabilizer feet C 750 S

08-531.98-01.00-00

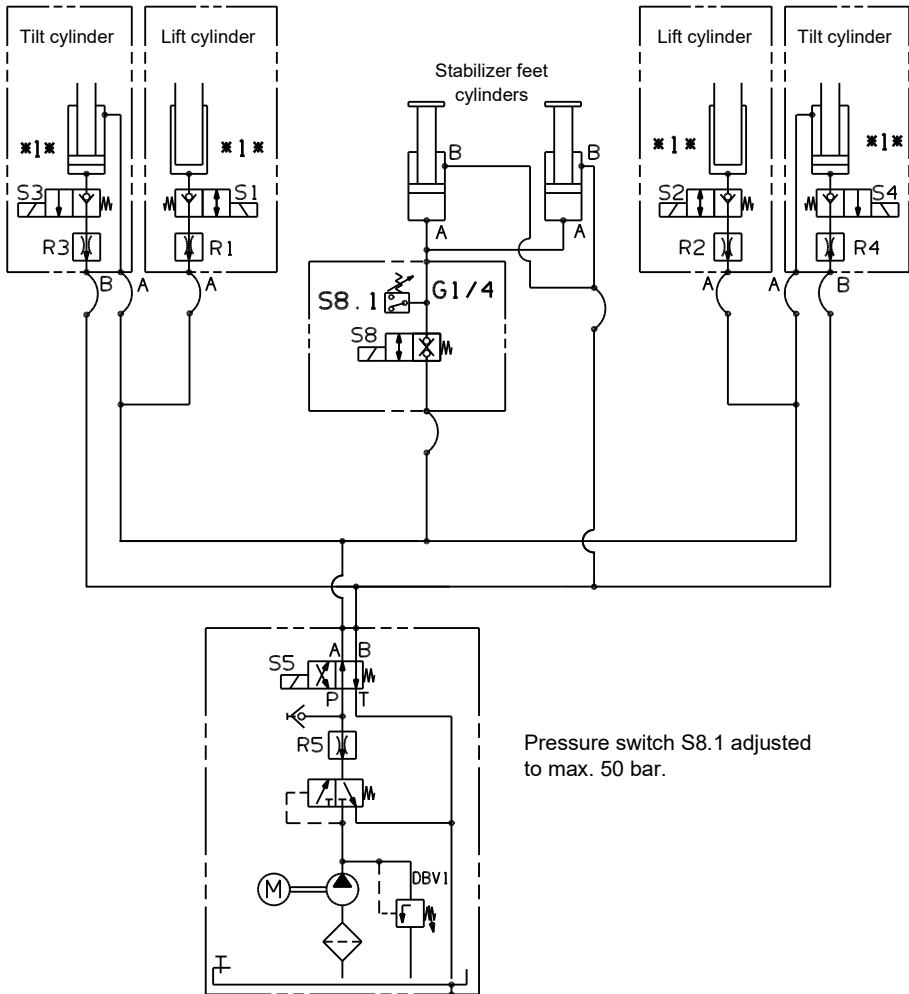

A 14.7. Standard tail lift with hydraulic override protection

99-514.98-01.00-00

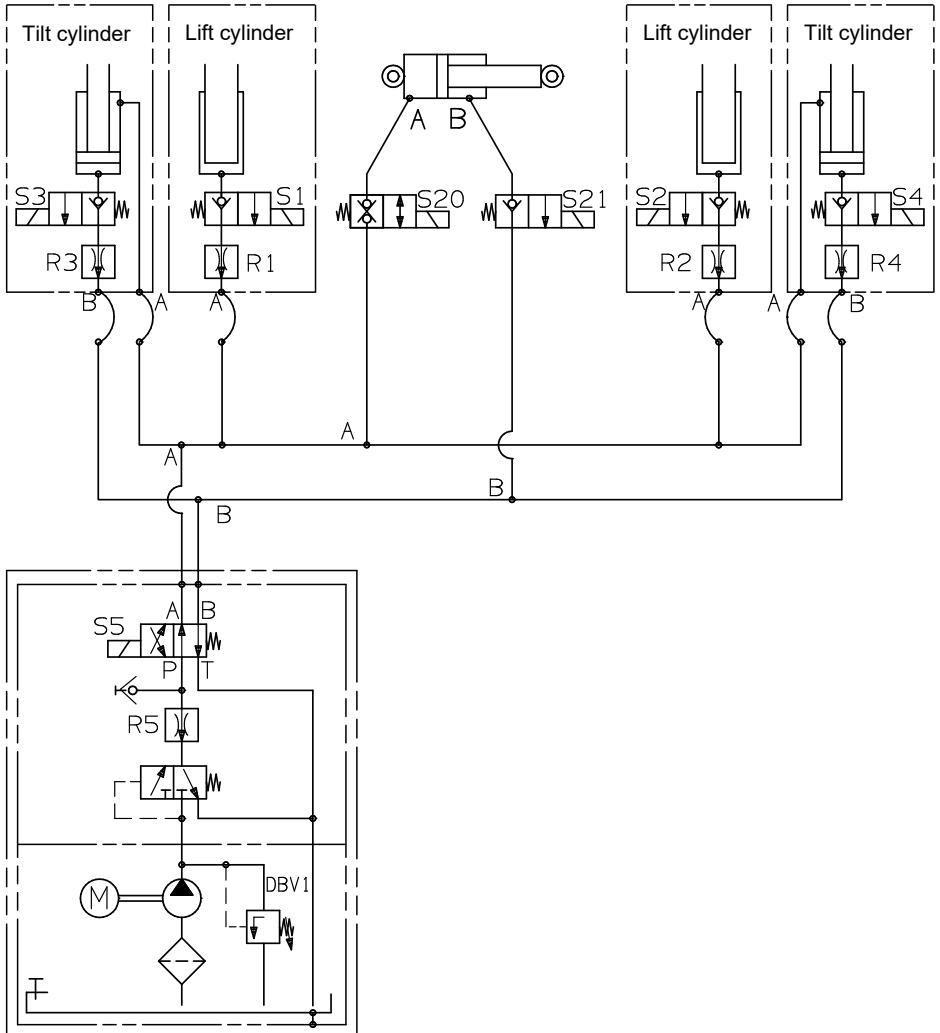

F G 14.8. Retractable tail lift

95-585.98-01.00-00

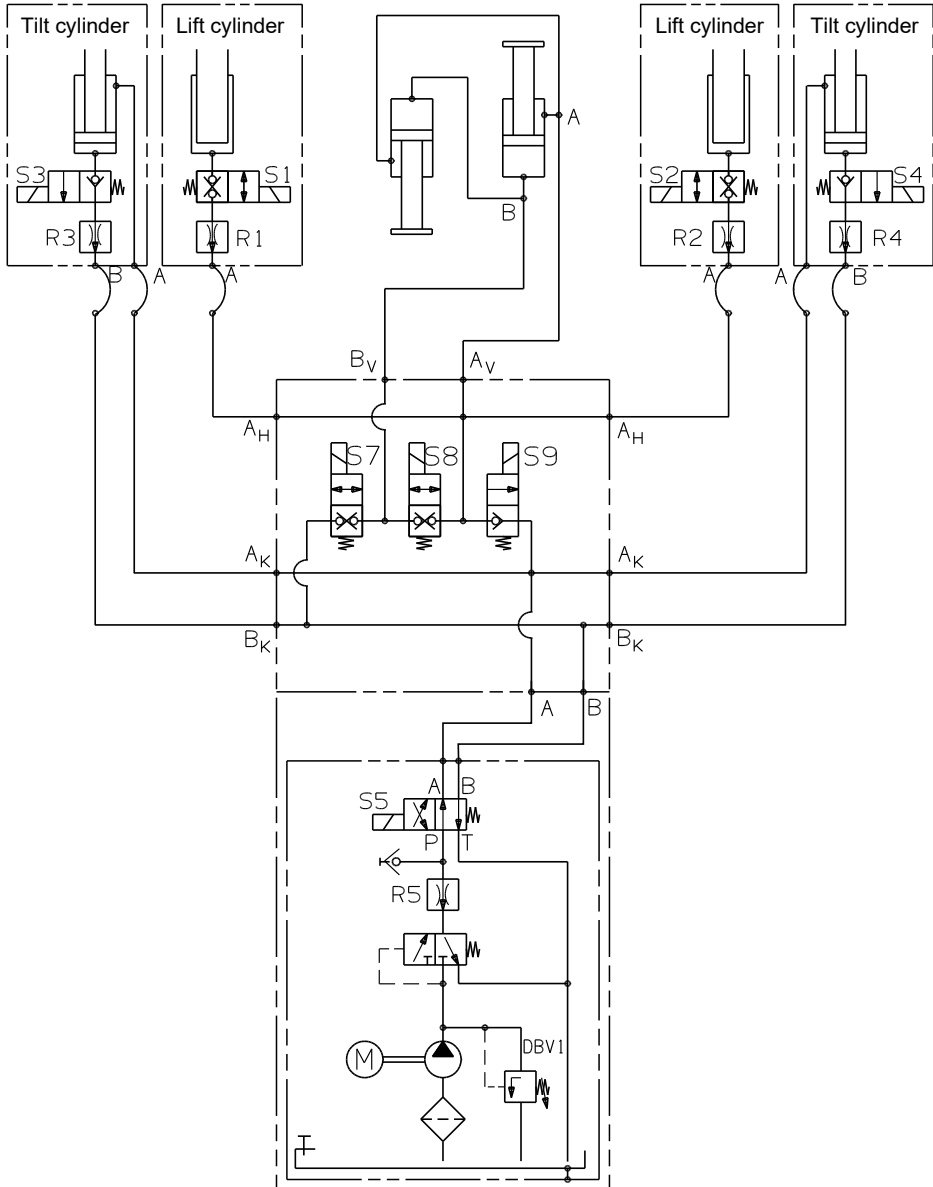

F 14.9. Retractable tail lift R 750 L, R 750 SM, R 1000 SM, R 1500 SK and R 2000 LK

00-538.01-98.01-00

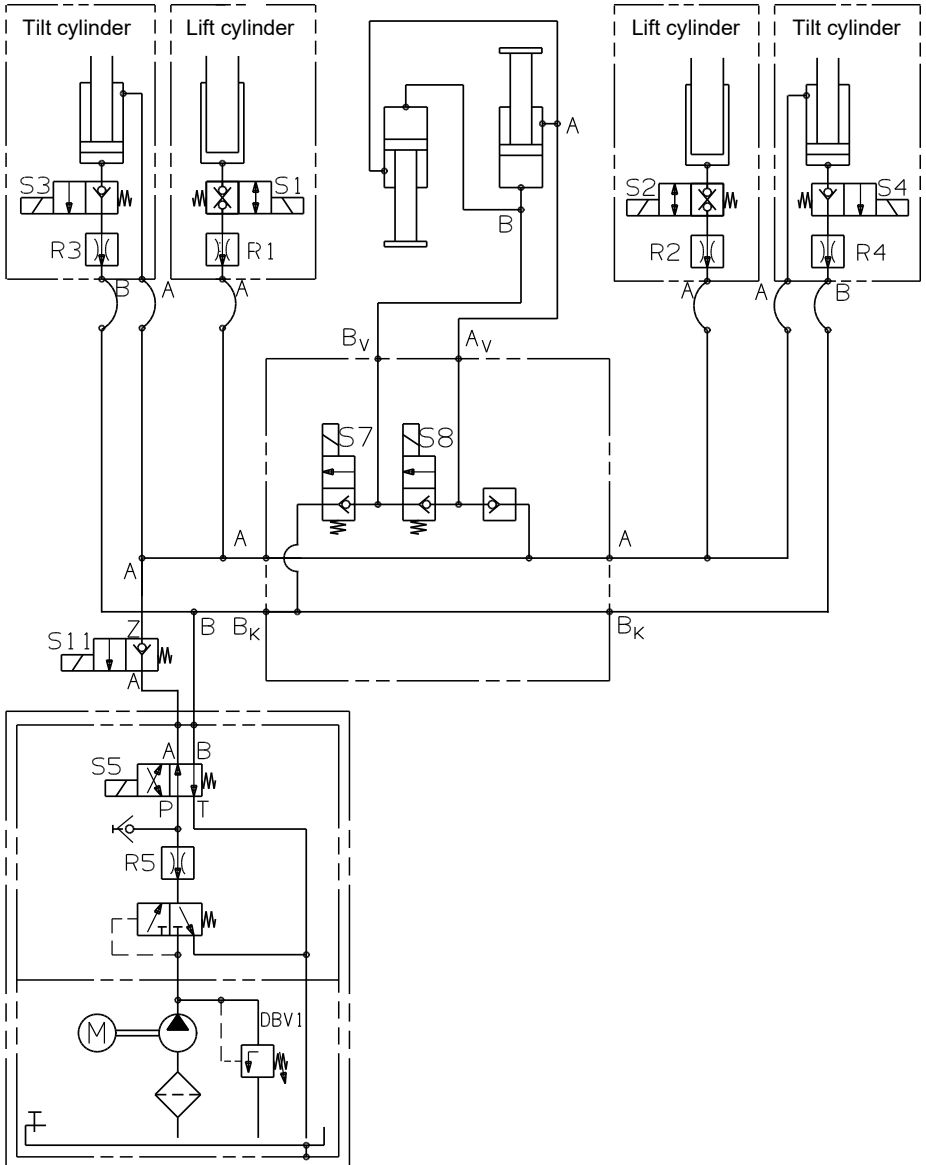

F 14.10. Retractable tail lift R 1500 L FLAT

99-553.98-01.00-00/3

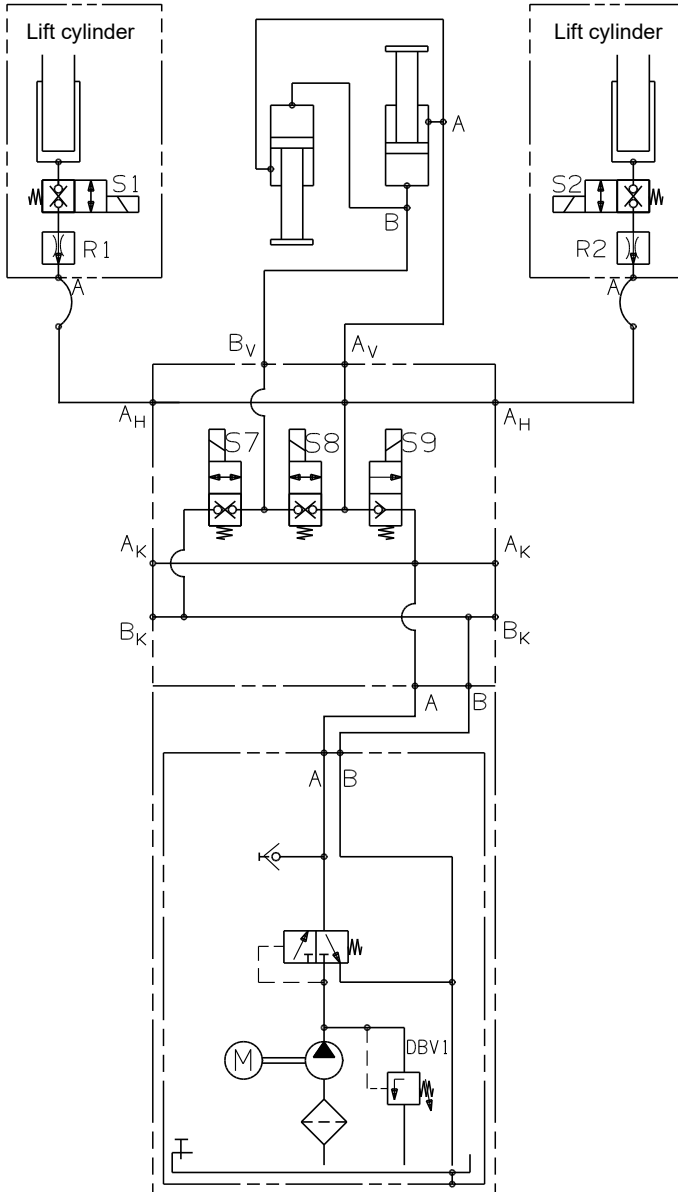

G 14.11. Retractable tail lift R 1500 SH and R 2000 LH

00-514.98-00.00-00

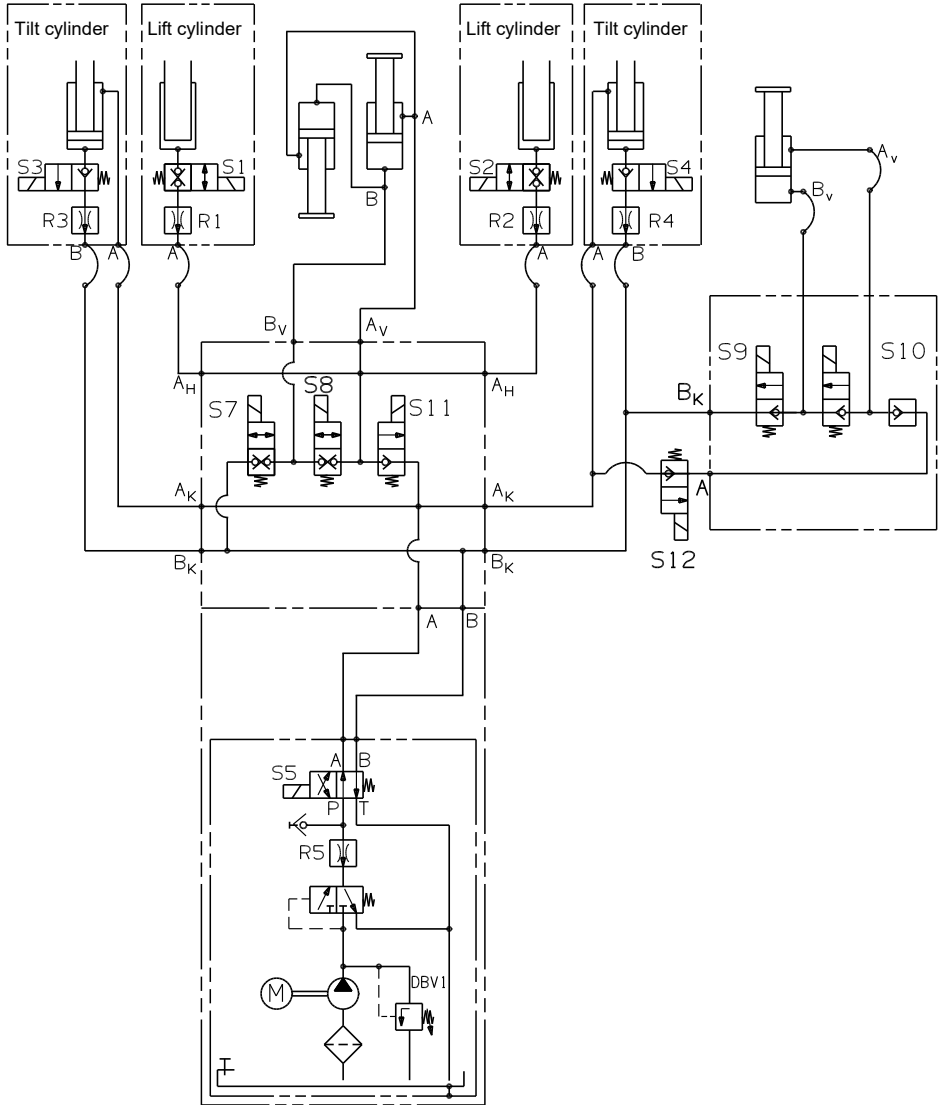

L 14.12. Foldable tail lift

93-505.60-08.00-00

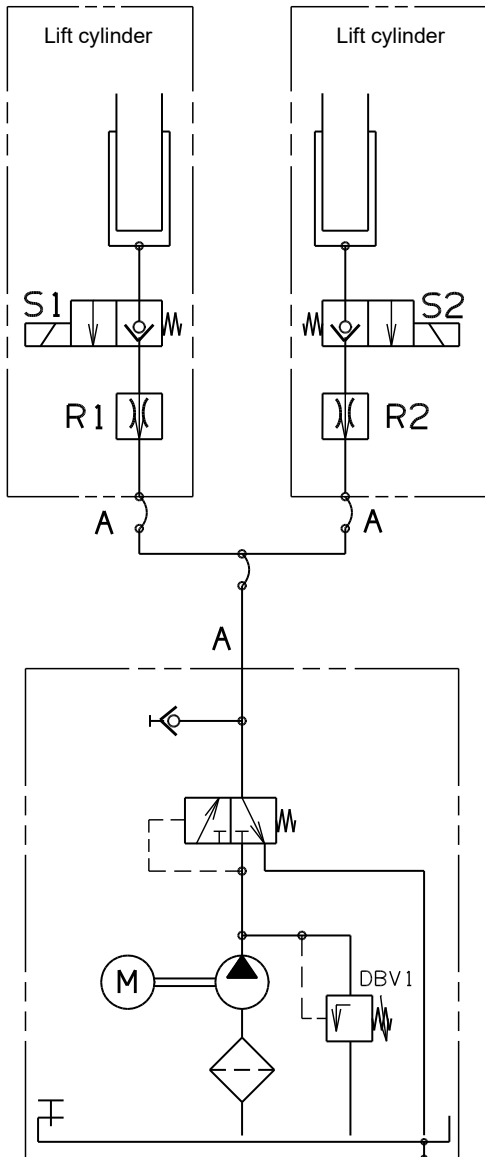

Ambulance 14.13. Ambulance models

15-551.98-01.00-00

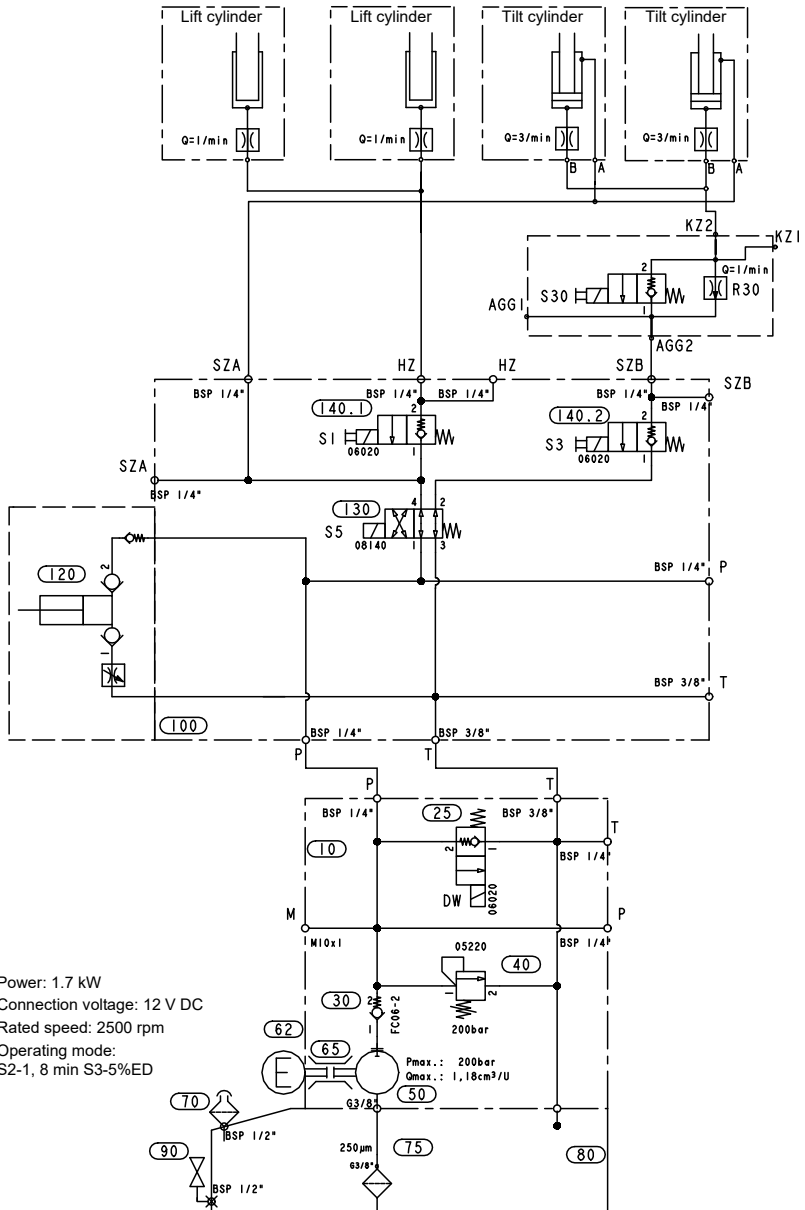

15. Lubricants and equipment

Recommended hydraulic oil

- Shell Tellus S2 V 15
Operating temperature: -20 °C to 60 °C

Special “cold” configuration

- Aero Shell Fluid 41
Operating temperature: -54 °C to 90 °C

Environmentally friendly oils

Biodegradable oils are more and more in demand for hydraulic units as environmental consciousness increases. We can supply you with an oil tested by us on request. The usage temperature for this oil is -20 °C to 60 °C. Please contact us.

If you use other oil types, cylinder seals may get damaged and cause disruptive noises.

Recommended lubricating oil/grease

For bearings on the tilt and lifting cylinders:

- Shell Gadus S2 (heavy-duty grease)
- Comparable grease

For movement rails on retractable tail lifts:

- Interflon Grease OG
- Comparable grease

For plastic bearings:

- Interflon LUBE EP+
- Comparable lubricating oil

16. Certificates in accordance with DIN EN 12642

TÜV NORD Mobilität GmbH & Co. KG

Certificate for securing a load with tail lifts Requirements specification and load prerequisites

8115029156-Z1-A1

The tails lifts described below fulfills the requirements according to
- DIN EN 12642 Code XL Annex A (2007-01) and (2017-03)

1 Tail lifts data / manufacturer

Manufacturer:	PALFINGER Tail Lifts GmbH Fockestraße 53 27777 Ganderkesee Tel.: +49 4221 853 326 E-Mail: v.walter@palfinger.com
Tail lifts type:	Standard - HLB with 1 tipping and 1 lifting cylinder with 2 tipping and 2 lifting cylinders
Platforms:	Aluminium and steel
Control arm length:	up to 1,100 mm

The tail lifts fulfill the requirements of DIN EN 12642 Code XL.

2 Tail lifts types and equipment data

	Permissible load masses Annex A	Proven max. test forces (DIN EN 12642 (2007-01) and (2017-03))
2.1. Tail Lift load capacity 500 kg to 750 kg - all pitches		
Platform dimensions:	Height: 1,200 - 2,000 mm Width: 1,750 - 2,600 mm Bearing bolt diameter Ø 25 mm	
Control arm length:	600 to 800 mm	
Nominal load:	500 kg to 750 kg	
Platform heights: up to 1,950 mm	3,000 kg	1,000 daN
Platform heights: up to 2,000 mm	5,000 kg	1,500 daN
2.2. Tail Lift load capacity 500 kg to 1000 kg - support tube ST180 and all pitches		
Platform dimensions:	Height: 1,200 - 2,000 mm Width: 1,750 - 2,600 mm Bearing bolt diameter Ø 25 mm	
Control arm length:	600 to 800 mm	
Nominal load:	500 kg to 1,000 kg	
Platform heights: up to 1,600 mm	8,000 kg	2,400 daN
Platform heights: up to 1,800 mm	7,500 kg	2,250 daN
Platform heights: up to 2,000 mm	7,000 kg	2,100 daN

This certificate is only valid in complete. It is based on the associated test report and gets void, with technical and/or legal changes

8115029156-Z1-A1
Page 1 of 3

TÜV NORD Mobilität GmbH & Co. KG

Permissible
load masses
Annex A

Proven max.
test forces
(DIN EN 12642
(2007-01) and
(2017-03))

2.3. Tail Lift load capacity 1000 kg to 1500 kg - all pitches

Platform dimensions: Height: 1,200 - 2,600 mm
Width: 1,750 - 2,600 mm
Bearing bolt diameter Ø 28 mm
Control arm length: 700 to 900 mm
Nominal load: 1,000 kg to 1,500 kg

Platform heights: up to 2,000 mm	12,000 kg	3,600 daN
Platform heights: up to 2,200 mm	11,000 kg	3,300 daN
Platform heights: up to 2,400 mm	10,000 kg	3,000 daN
Platform heights: up to 2,600 mm	9,000 kg	2,700 daN

2.4. Tail Lift load capacity 1500 kg to 2500 kg - all pitches

Platform dimensions: Height: 1,200 - 2,800 mm
Width: 1,750 - 2,600 mm
Bearing bolt diameter Ø 36 mm
Control arm length: 700 to 1,100 mm
Nominal load: 1,500 kg to 2,500 kg

Platform heights: up to 2,000 mm	16,000 kg	4,800 daN
Platform heights: up to 2,200 mm	14,500 kg	4,350 daN
Platform heights: up to 2,400 mm	13,000 kg	3,900 daN
Platform heights: up to 2,600 mm	11,500 kg	3,450 daN
Platform heights: up to 2,800 mm	10,000 kg	3,000 daN

2.5. Tail Lift load capacity 2000 kg to 3000 kg - all pitches

Platform dimensions: Height: 1,200 - 3,000 mm
Width: 1,750 - 2,600 mm
Bearing bolt diameter Ø 40 mm
Control arm length: 800 to 1,100 mm
Nominal load: 2,000 kg to 3,000 kg

Platform heights: up to 2,000 mm	21,000 kg	6,300 daN
Platform heights: up to 2,200 mm	19,000 kg	5,700 daN
Platform heights: up to 2,400 mm	17,000 kg	5,100 daN
Platform heights: up to 2,600 mm	15,000 kg	4,500 daN
Platform heights: up to 2,800 mm	13,000 kg	3,900 daN
Platform heights: up to 3,000 mm	11,000 kg	3,300 daN

3 Designations / conditions for loading

- Coefficient of friction $\mu_D \geq 0,3$
- Form fit of cargo in and against as well as transverse to direction of travel
- Cargo in contact to front wall
- Width of cargo min. 2,400 mm
- Distance cargo / rear doors ≤ 150 mm

This certificate is only valid in complete. It is based on the associated test report and gets void, with technical and/or legal changes

8115029156-Z1-A1
Page 2 of 3

TÜV NORD Mobilität GmbH & Co. KG

4 Designations for cargo (examples)

- Piece goods, stable in form and tip-resistant
- Palletised goods, stable in form and tip-resistant

5 Summary

When stipulations of par. 2 and 3 are fulfilled, the cargo securing for goods described at par. 4 is assumed by the stability of the tail lifts. Additional load securing methods like lashing down or direct lashing are not necessary.

When the conditions listed before are kept, the tail lifts are able to secure the described cargo items with regard to the requirements of the generally recognised rules of technology - like acceleration values according to EN 12195-1 (Road Traffic), German VDI guideline 2700 ff and the expert reports and certificates based on these generally recognised rules of technology. This confirmation of sufficient securing of the load also takes into account the legal requirements of safety of loads, which are listed in §§ 22 and 23 and also 30 of German StVZO.

For all cases of loading deviating from conditions listed before, additional cargo securing methods according to German VDI guideline 2700 ff are mandatory.

6 Basics

Test Report TÜV NORD Mobilität GmbH & Co. KG No.: LS 0108545

Following EN 12642, the condition of the vehicle body has to be examined and the result to be recorded according to manufacturer's specifications. Relevant national guidelines (e.g. Germany: VDI 2700 or similar / annually inspection by an educated expert) must be observed.

TÜV NORD Mobilität GmbH & Co. KG
 IFM - Institut für Fahrzeugtechnik und Mobilität
 Schönscheidtstr. 28, DE 45307 Essen
 Office Hannover
 Specialist group Load Securing
ladungssicherung@tuev-nord.de
 +49 511 998 61274

Hannover, 24.06.2021

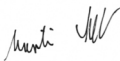

Martin Keller

PALFINGER Tail Lifts GmbH

By signing this certificate, PALFINGER Tail Lifts GmbH confirms, that the structural stability of the tail lifts delivered to the customer meets the requirements of the test sample certified by TÜV NORD.

27777 Ganderkesee (D), 25.06.2021



Volker Walter

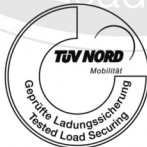

17. Index

7-segment display	154
Adjusting ground alignment	25
Adjusting the hydraulic stabilizer feet	27
Checking the oil level.....	141
easy move®	77, 79, 81, 101, 104
Emergency operation	168
Faults.....	152
Foot control.....	119
Hand cable control.....	123
Hand pump operation (ambulance models).....	133
Hydraulic units	145
Intended use.....	12
Loading ramp.....	48
Lubrication	143
Model overview.....	17
Operation.....	52
Platform emergency opening.....	170
Platform lock.....	42
Programming the button code on the Slimpanel.....	32
Quick down.....	71, 72, 126
Radio remote control	125
Railing	42
Resetting the service counter	150
Roll bar	45
Service and maintenance	135
Service partners	152
Switching off	50
Switching on	34
Tilt sensor B15S	27
Tilt switch B13	25

PALFINGER Tail Lifts GmbH

Fockestraße 53
D-27777 Ganderkesee/Hoykenkamp
Tel.: +49-4221 8530
Fax: +49-4221 87536
infombb@palfinger.com
www.palfinger.com

PALFINGER Hayons S.A.S.

Rue de l'Eglise
F-61310 Silly en Gouffern
Tel.: +33-2 33 12 44 00
Fax: +33-2 33 12 44 01
francembb@palfinger.com
www.palfinger.com

PALFINGER Tail Lifts s.r.o.

Gogolova 18
SK-85101 Bratislava
Tel.: +421-252 636 611
Fax: +421-252 636 612
mbbsk@palfinger.com
www.palfinger.com