

TRUCK-MOUNTED FORKLIFTS CENTER SEAT SERIES

BRICK AND BLOCK KEY FEATURES



FHC 55 STD
FHC 55 P

TRUCK-MOUNTED FORKLIFTS

FHC 55 STD
FHC 55 P

IMPROVED OVERALL VISIBILITY

- **PALFINGER's** panoramic visibility sets a new standard in operator visibility and safety. The fork carriage utilizes Class III fork boards with a wide Class IV opening. Lift cylinders positioned behind the mast uprights give way to an unprecedented forward field of vision. As a result, seeing the fork tips has never been easier.

SIDE MOUNT CONTROLS FOR MOUNTING AND DISMOUNTING OFF OF TRANSPORT TRUCK

- **The PALFINGER** Ground Control System comes standard on all models and allows operators to mount and dismount the forklift from a truck or trailer without climbing on board.
- Once the forklift is started, operators use three (3) ground-level electro-hydraulic switches on the side-mounting control panel to tilt, extend, and lower the machine through the dismount sequence.
- By eliminating operator slip and strain hazards from climbing on and off a truck-mounted forklift (especially in cold, wet, and icy conditions), **PALFINGER's** Ground Control System raises the standard of Operator Safety. Operators are no longer required to overextend themselves by trying to climb up on the forklift to dismount from the truck or trailer.
- Reduced strain on operator, therefore, reduction in the chance of workplace injury due to climbing up into the cab.

MOST SPACIOUS CABIN IN THE INDUSTRY

- Unobstructed, larger floor area.
- The largest and easiest operator compartment to work in.
- The pedal mechanism is under the floor space
- Motion and acceleration pedals ergonomically level with each other for optimum operator comfort.
- Comfortable angle of foot pedal.
- The steering column does not mount to the floor; therefore eliminating trip hazard.
- Floorboard features an anti-slip high-friction pattern.
- Room to accommodate the largest of work boots.

EASE OF ENTRY/EXIT INTO CAB

- Wide, ergonomically correct, and spaced steps for minimal effort of cab entry and exit.





GROUND LEVEL FUEL FILL

- Operators can easily fill with fuel from the ground level without having to climb up onto the machine.

QUICK AND EASY ACCESS TO SERVICE AND MAINTENANCE POINTS

- The quick-release, tilt-up hood, and hinged rear door provide service-friendly access to all engine components and service points. In addition, the hydrostatic pump and integrated differential lock are easily accessible from the front for service and maintenance.
- All **PALFINGER** systems meet the highest industry standards. Electrical connections are IP68-rated. Hydraulic hosing is minimized, and steel hydraulic lines are extensively used throughout to minimize leaks.

Reach Model:

- Our double reach system enables a full capacity of 5,500 lbs. clear off deck across the entire bed when properly positioned with the mast rest pads.
- Our patented reach system provides the operator with additional tilt and side shift at the fork carriage while the mast remains stationary.
 - This enables even more control of load and minimizes damage.

TECHNICAL SPECIFICATIONS

FHC 55

MODEL	FHC 55	FHC 55 P
TYPE	Standard	Reach
CAPACITY @ 24" LOAD CENTER	5,500 lbs.	
DIESEL ENGINE	56 hp	
ENGINE EMISSION COMPLIANCE EPA	TIER 4 Final	
MAXIMUM ENGINE RPM	2,700 rpm	
ELECTRICAL SYSTEM	12 Volt	
DRIVE WHEELS (ALL WITH BRAKES)	3	
STEERING	Hydrostatic	
TIRE TYPE FRONT : SKID STEER	31" x 15.5" - 15" 8 PLY	31" x 15.5" - 15" 8 PLY
TIRE TYPE REAR : TRACTOR GRIP	31" x 15.5" - 15" 8 PLY	
TIRE OUTSIDE DIAMETER (Front / Rear)	31" / 31"	
TIRE WIDTH (Front / Rear)	15 1/2" / 15 1/2"	15 1/2" / 15 1/2"
MAXIMUM SPEED	7 mph	
MAXIMUM GRADABILITY (4 Way Mode)	30%	30%
TURNING RADIUS	81"	87"
UNLADEN WEIGHT EXCLUDING FORKS	120" MAST 6,292 lbs 144" MAST 6,412 lbs	120" MAST 7,342 lbs 144" MAST 7,462 lbs
WORKING PRESSURE FOR ATTACHMENTS	3,000 psi	
TILT OF MAST (FORWARD / BACK)	10° / 8°	
TILT OF FORK CARRIAGE (FORWARD / BACK)		0° / 6°
SIDESHIFT	6"6"	5"
FORK SECTION : LUMBER (L x W x H)	48" x 4" x 1 3/4" 48" x 2" x 2" 48" x 6" x 2"	48" x 4" x 2" 48" x 2" x 2" 48" x 6" x 2"
MAST CARRIAGE TRAVEL	25 1/4"	31 1/4"
REACH ACROSS TRUCK BED		51"
COUNTERWEIGHTS	No	
HEIGHT TO TOP OF CANOPY	101"	
FORK CARRIAGE WIDTH	47 1/4" (CLASS IV 25" OPENING)	
FRAME OPENING	58"	
OVERALL WIDTH [4Way Mode]	101 1/2" 101"	
OVERHANG	72"	78"
WHEEL BASE	71 1/2"	77 1/2"
C. OF G. FROM FORK FACE	24"	25 1/2"
LIFT HEIGHT	120" 144"	
MAST HEIGHT COLLAPSED	88 3/4" 100 3/4"	
MAST HEIGHT RAISED	148 3/4" 172 3/4" 148 3/4" 172 3/4"	201" 225"
GROUND CLEARANCE	11"	
FACE OF FORK TO CENTER OF FRONT TIRE	9"	
ANSI STANDARD	B56.14	

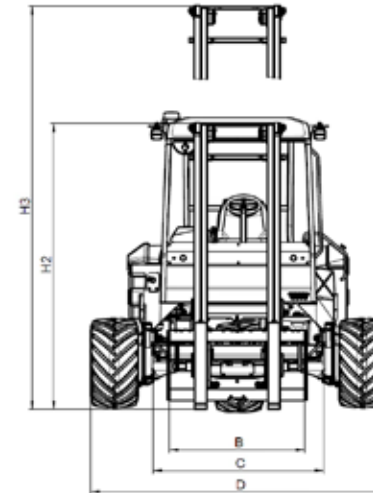
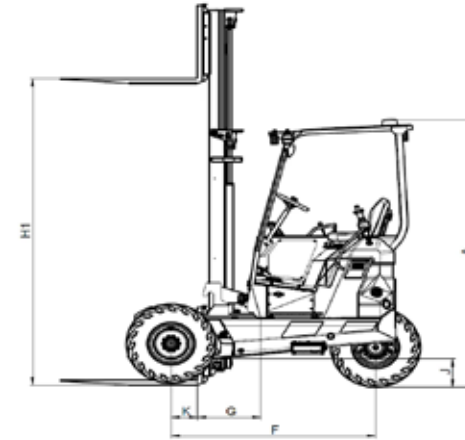

Forklifts shown in this brochure are partially optional equipped and do not always correspond to the standard version.

Country-specific regulations must be observed. Dimensions may vary. Subject to technical changes, errors and translation mistakes.

TMF_FHC_V1_202501

Palfinger North America, LLC
 2324 Palmer Dr.
 Schaumburg, IL 60173
 224-308-1754

PALFINGER.COM