

# HYDRAULIC SERVICE CRANE PSC 8029

LIGHTER | LONGER | STRONGER

LIFETIME EXCELLENCE



# BUILT TO LAST

Meeting or exceeding all ASME and OSHA standards, the PSC 8029 is a full hydraulic service crane with 8,000 lbs capacity. The PSC 8029 hydraulic service crane comes standard with simultaneous multi-function proportional radio remote controls, superior weight-to-lift ratios, and 29' of reach. The crane is exclusively E-coated by PALFINGER for the best rust protection in the industry.

## E-COAT PROTECTION

Most rust resistant telescopic crane on the market



- MEDIA BLAST**  
A high quality process that removes any surface imperfections and provides an optimized surface for E-coating.
- E-COAT**  
Automotive grade and environmentally friendly coating process is applied with precision over the entire product ensuring superior corrosion protection.
- TOP COAT**  
All E-coated steel components receive a top coat finish that ensures maximum durability.

**LIGHTER.**  
PALFINGER's service cranes are as much as **30% lighter** than the competition — without sacrificing strength or reach. Less weight means more payload for tools and supplies necessary on the job site.

**LONGER.**  
Up to **30% longer** than the competition, PALFINGER's service cranes have the longest reach in the industry. More reach means fewer setup adjustments on the job site and improved access for those challenging lifts. Standard boom lengths are 16', 25, and 29' depending on the size of the crane.

**STRONGER.**  
PALFINGER's service cranes are up to **20% stronger** than the competition, with a superior lifting moment rating and load chart to do more work in more places. With PALFINGER's safety systems, including the exclusive winch damage prevention system, lifting more is also safer than ever before.

# STANDARD FEATURES



- PLANETARY WINCH**  
Planetary winch provides speed and durability.
- HORSE HEAD**  
Low profile design. Optional boom tip hook and lights. No A2B components to interfere with operation.
- LOAD BLOCK STOWING BRACKET**  
Bracket and pads designed to keep load block from contacting the boom when stowed.



- HEXAGONAL BOOMS**  
Ultra-low maintenance high tensile strength self-centering single weld boom sections powered by internal extension cylinders.
- CYLINDERS**  
Internal extension cylinders for 29' of hydraulically powered outreach. All cylinders are E-coated and use a 5 stage marine grade seal system.
- CONTROL SYSTEM**  
Features a standard proportional wireless remote control unit, integrated E-stop button, warning horn and manual valve activation capability. Cranes are controlled with 12V DC power supply.

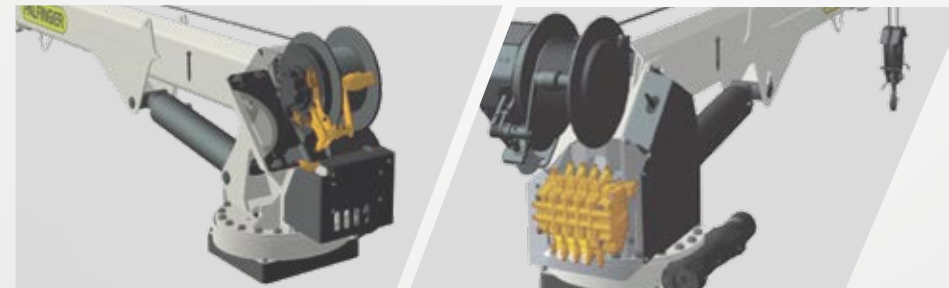

- 3RD WRAP LIMITING SYSTEM**  
Integrated system prevents wire rope spool off, ensuring three wraps remain on drum. Exceeds ASME B30.5.
- PROPORTIONAL CONTROL**  
Through the control valve, fully proportional control of all functions is standard.



**3-YEAR WARRANTY**  
PALFINGER service cranes come with an industry leading 3-year warranty on all structural components

# OPTIONS & ACCESSORIES

Many optional features are available for PALFINGER service cranes to meet your demands on the job. Contact your PALFINGER Representative to learn more!

## PERSONNEL BASKET CRANE ACCESSORY (PATENT PENDING)

Industry-first from PALFINGER designed specifically for service cranes with 5,000 lbs. capacity and above. Quickly set up and attach basket to crane for maximum efficiency on the job. Folds into a compact storage box and mounts onto the body for transport.

Personnel Basket Capacity	300 lbs.
Personnel Basket Weight	280 lbs.
Complete Installation (incl. boxes):	400 lbs.



# OPTIONS & ACCESSORIES



**BOOM TIP HOOK**  
PALFINGER exclusive 2.5 ton capacity boom tip hook. Horsehead has threaded weldment for mounting.



**ELS SYSTEM EASY LOWERING OF LOAD BLOCK**  
Unique solution to lower the hooking point for the load block. Winch is used to lift load block in its stowed position.



**BOOM TIP LIGHTING**  
With the addition of a retractable cord reel we bring power to the boom tip to light dual work lights that swing freely while raising and lowering the boom to illuminate your working area.



**BOOM REST**  
Non-marring boom rest that supports the crane while protecting the paint finish.



**OUTRIGGERS FOR ADDED STABILITY**  
Support your lifting application needs with manual and hydraulic outrigger options.



**P2 RADIO REMOTE CONTROL**  
Paddle-style controller offers the possibility to completely eliminate the radio signal when the cord is plugged into the receiver.



**PROTECTIVE CASE WITH BELT LOOP KEEPS REMOTE AT YOUR SIDE**  
Nylon case with clear plastic cover protects your remote control from harsh weather elements, while the belt loop allows you to attach the remote to your work belt for added convenience on the job.



**SILICONE COVER FOR REMOTE KEEPS REMOTE CLEAN**  
Flexible silicone cover helps keep dust, dirt, and grime off of your remote control – so you can focus on controlling your service crane and not cleaning the remote.



**REMOTE STORAGE BRACKET SECURELY STOWS REMOTE**  
Stow the remote control using the metal storage bracket and mount it in the cab or the crane compartment. Thanks to the remote magnet, the remote will be held securely in place during transport.





# TECHNICAL SPECIFICATIONS

## WINCH DAMAGE PREVENTION SYSTEM

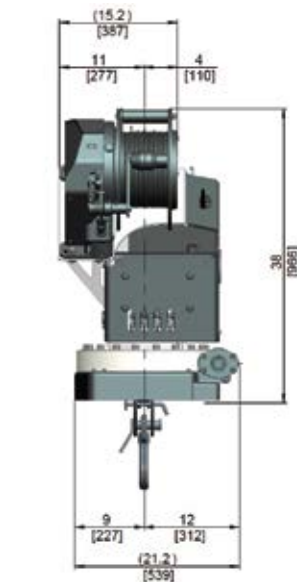
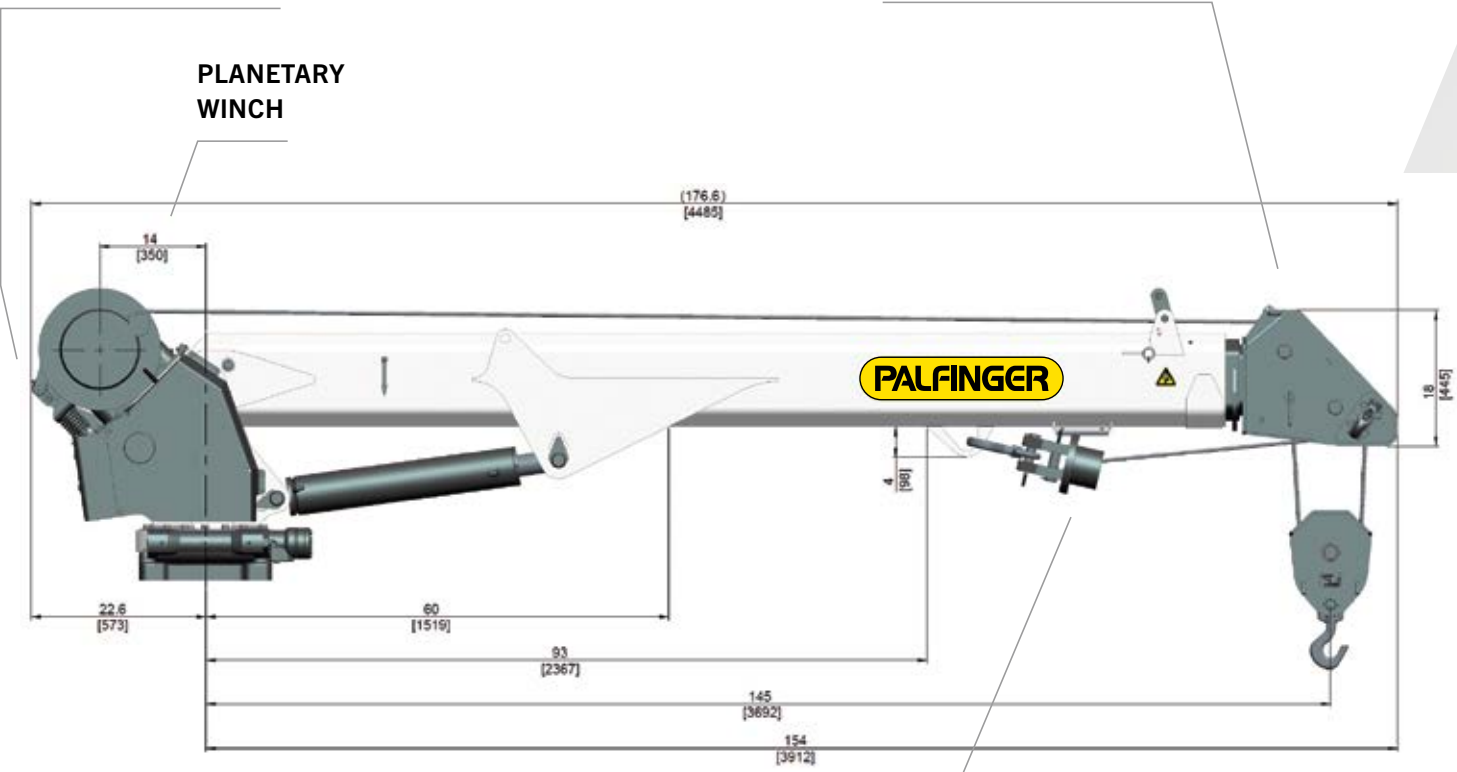

LOAD BLOCK STOWING BRACKET

## HORSE HEAD

## PLANETARY WINCH

## LOAD CHART

### CRANE RATING

Rated lifting moment	43,000 ft*lbs. (58.3 kNm (5.9 mt))
Maximum lifting moment	49,180 ft*lbs. (66.5 kNm (6.8 mt))
Boom extensions	29 ft. (8.9 m)
Crane weight	2,149 lbs. (975 kg)
Hydraulically powered extensions	2 hydraulic

### CONTROL SYSTEM

Wireless remote control unit	
Integrated E-stop button	
Manual emergency valve activation capability	
Integrated warning horn	
12V DC power supply	

### ROTATION SYSTEM

Slewing torque	4,920 ft*lbs. (6.8 kNm (0.7 mt))
Slewing angle	400 ° rotation
Worm gear drive with surface hardened gear teeth	

### STANDARDS (meets or exceeds)

Crane design	ASME B30.5	OSHA 1910.28
Calculation	EN 12999 H1,B6	

### PLANETARY GEAR WINCH

Max. winch force single line	4,000 lbs. (1,820 kg)
Max. winch force double line	8,000 lbs. (3,650 kg)
Max. line speed	60 ft./min (18.2 m/min)
Cable size and length	7/16" x 120' (11 mm x 36.5 m)
Two-block damage prevention system	
3rd wrap end stop system	

### HYDRAULIC SYSTEM

Operating pressure	3,045 psi (21 Mpa (210 bar))
Required oil flow	8-12 GPM (30-45 l/min)
Electronic overload protection system	
Five stage marine-grade seals on all cylinders	
Non integrated load-holding valves on all cylinders	

### CRANE | CHASSIS INTERFACE

Base plate dimension	17.75" x 17.75" (450 mm x 450 mm)
Hole pattern	14.75" x 14.75" (375 mm x 375 mm)
Mounting bolts	4 x 1 1/4" -12 UNF

### CHASSIS RECOMMENDATION

Chassis style	Conventional
Minimum GVWR	Class 5 (19,500 lbs. (8,845 kg))

Weights of load-handling devices are part of the load lifted and must be deducted from the capacity.

....lbs  
....kg  
Boxes denote two-part line required.

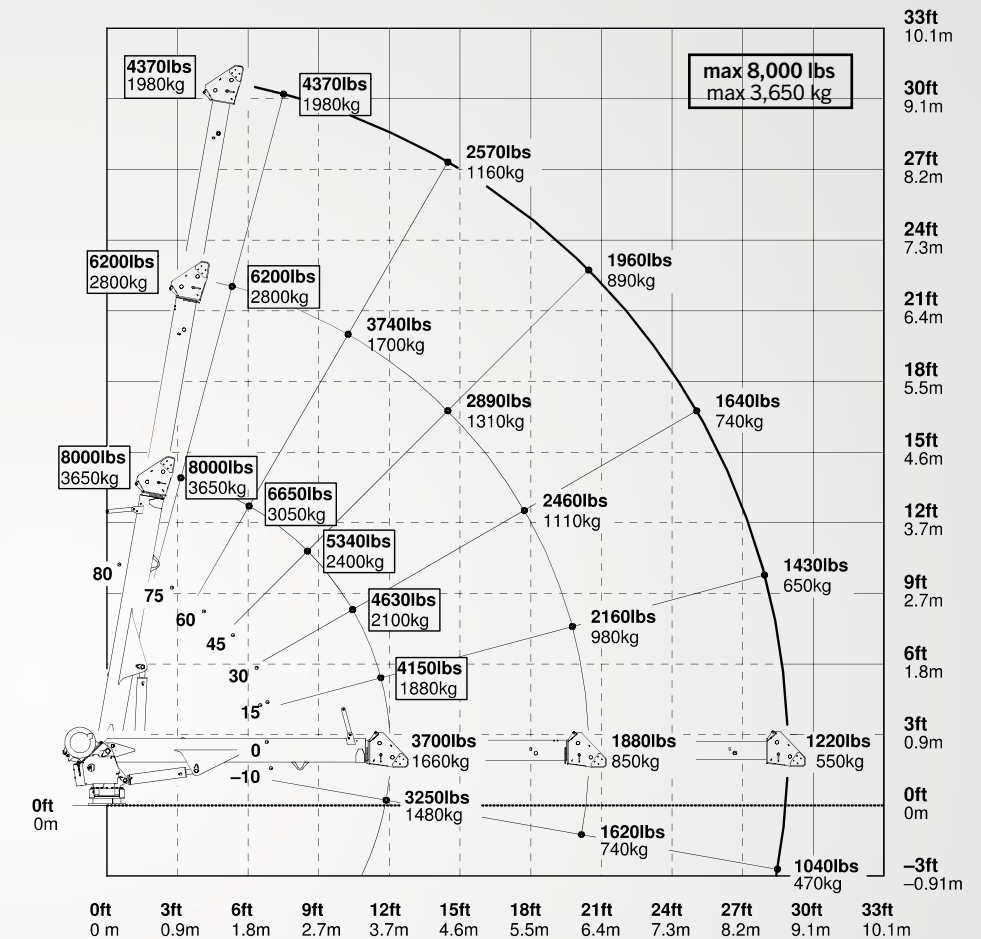

# PRODUCT RANGE

## TECHNICAL SPECIFICATIONS

MODEL	CAPACITY	RATED LIFTING MOMENT	MAX LIFTING MOMENT	BOOM EXTENSIONS	BOOM LENGTH	WINCH SPEED	STANDARD WEIGHT	CHASSIS SPECIFICATION
PSC 3216 E	4,000 lbs. (1,814 kg)	12,500 ft*lbs. (17 kNm (1.7 mt))	14,560 ft*lbs. (19.6 kNm (2 mt))	1 Hydraulic + 1 Manual (2 Hydraulic Option)	16 ft. (4.9 m)	21.2 ft./min (6.46 m/min)	650 lbs. (295 kg)	Class 3
PSC 3216 H	4,000 lbs. (1,814 kg)	12,500 ft*lbs. (17 kNm (1.7 mt))	14,560 ft*lbs. (19.6 kNm (2 mt))	1 Hydraulic + 1 Manual (2 Hydraulic Option)	16 ft. (4.9 m)	29.7 ft./min (9.05 m/min)	630 lbs. (286 kg)	Class 3
PSC 4016 E	4,000 lbs. (1,814 kg)	18,500 ft*lbs. (25.1 kNm (2.6 mt))	23,235 ft*lbs. (31.4 kNm (3.2 mt))	1 Hydraulic + 1 Manual (2 Hydraulic Option)	16 ft. (4.9 m)	21.2 ft./min (6.46 m/min)	650 lbs. (295 kg)	Class 3
PSC 4016 H	4,000 lbs. (1,814 kg)	18,500 ft*lbs. (25.1 kNm (2.6 mt))	23,235 ft*lbs. (31.4 kNm (3.2 mt))	1 Hydraulic + 1 Manual (2 Hydraulic Option)	16 ft. (4.9 m)	29.7 ft./min (9.05 m/min)	630 lbs. (286 kg)	Class 3
PSC 4025 E	4,000 lbs. (1,814 kg)	18,500 ft*lbs. (25.1 kNm (2.6 mt))	20,585 ft*lbs. (27.9 kNm (2.9 mt))	2 Hydraulic	25 ft. (7.6 m)	21.2 ft./min (6.46 m/min)	1,010 lbs. (458 kg)	Class 3
PSC 4025 H	4,000 lbs. (1,814 kg)	18,500 ft*lbs. (25.1 kNm (2.6 mt))	20,585 ft*lbs. (27.9 kNm (2.9 mt))	2 Hydraulic	25 ft. (7.6 m)	29.7 ft./min (9.05 m/min)	995 lbs. (451 kg)	Class 3
PSC 5025 E	5,000 lbs. (2,268 kg)	32,500 ft*lbs. (44.2 kNm (4.5 mt))	36,360 ft*lbs. (49.3 kNm (5 mt))	2 Hydraulic	25 ft. (7.6 m)	18.8 ft./min (5.73 m/min)	1,170 lbs. (530 kg)	Class 4
PSC 5025 H	5,000 lbs. (2,268 kg)	32,500 ft*lbs. (44.2 kNm (4.5 mt))	36,360 ft*lbs. (49.3 kNm (5 mt))	2 Hydraulic	25 ft. (7.6 m)	56 ft./min (17.07 m/min)	1,155 lbs. (525 kg)	Class 4
PSC 6025 E	6,000 lbs. (2,750 kg)	38,500 ft*lbs. (52.2 kNm (5.3 mt))	42,800 ft*lbs. (58.0 kNm (5.9 mt))	2 Hydraulic	25 ft. (7.6 m)	43.3 ft./min (13.20 m/min)	1,280 lbs. (580 kg)	Class 4
PSC 6025 H	6,000 lbs. (2,750 kg)	38,500 ft*lbs. (52.2 kNm (5.3 mt))	42,800 ft*lbs. (58.0 kNm (5.9 mt))	2 Hydraulic	25 ft. (7.6 m)	51 ft./min (15.54 m/min)	1,230 lbs. (560 kg)	Class 4
PSC 8029 H	8,000 lbs. (3,650 kg)	43,000 ft*lbs. (58.3 kNm (5.9 mt))	49,180 ft*lbs. (66.5 kNm (6.8 mt))	2 Hydraulic	29 ft. (8.9 m)	60 ft./min (18.28 m/min)	2,149 lbs. (975 kg)	Class 5
PSC 10829 H	10,800 lbs. (4,900 kg)	62,000 ft*lbs. (84.1 kNm (8.6 mt))	68,900 ft*lbs. (93.2 kNm (9.5 mt))	2 Hydraulic	29 ft. (8.9 m)	60 ft./min (18.28 m/min)	2,407 lbs. (1,092 kg)	Class 6
PSC 12529 H	12,500 lbs. (5,700 kg)	72,000 ft*lbs. (97.6 kNm (10 mt))	79,450 ft*lbs. (107.7 kNm (11 mt))	2 Hydraulic	29 ft. (8.9 m)	60 ft./min (18.28 m/min)	2,731 lbs. (1,239 kg)	Class 6
PSC 14029 H	14,000 lbs. (6,400 kg)	86,000 ft*lbs. (116.6 kNm (11.9 mt))	94,676 ft*lbs. (128.4 kNm (13 mt))	2 Hydraulic	29 ft. (8.9 m)	60 ft./min (18.28 m/min)	2,833 lbs. (1,285 kg)	Class 7



PROUDLY ASSEMBLED  
in the USA

OSP-PSC8029 | 06/20

Cranes shown in the leaflet are partially optional equipped and do not always correspond to the standard version. All PSC models are subject to change as PALFINGER updates, improves, and technologically advances their cranes and the industry.

OMAHA STANDARD PALFINGER  
3501 S. 11th Street | Council Bluffs, IA  
51501-0876 | USA  
T + 1 800 279 2201  
info@palfingerna.com

**PALFINGER.COM**