

PALFINGER



LIFTGATES

OWNER'S MANUAL

MiniFix, 1100 lbs. Capacity

MiniFix, 1320 lbs. Capacity

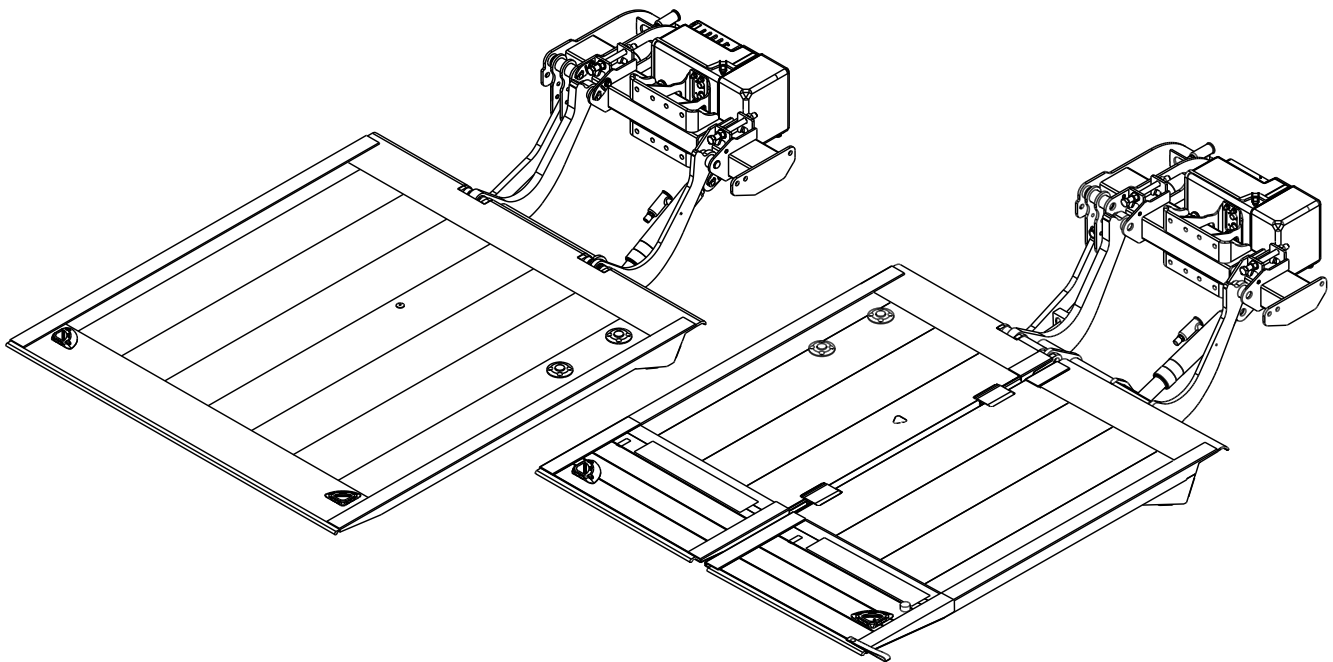

MiniFix 1100/1320 Owner's Manual
Document Part Number: 90-0913-100 / 13-689_90-00_01-00
ECN-M1621, Rev. 1.5, 02-02-22
Copyright © 2022 Palfinger Liftgates LLC.
All rights reserved.

Information in this document is subject to change without notice.
Visit www.palfinger.com for up to date information and notifications.

If you received this product with damaged or missing parts,
contact Palfinger Liftgates at (888) 774-5844



15939 Piuma Ave.
Cerritos, CA 90703
Tel: (888) 774-5844
Fax: (562) 924-8318



572 Whitehead Road.
Trenton, NJ 08619
Tel: (609) 587-4200
Fax: (609) 587-4201

Table of Contents

1	Manual Update	5
2	Safety Information	6
3	Important Notes	7
	3.1 Attention	7
	3.2 Important Notes	7
	3.3 General Information	8
	3.4 Improper Useage	9
4	Important Information	10
5	General View of Liftgate	12
	5.1 Standard Minifix Liftgate – Single Piece Platform	12
	5.2 Split Platform Minifix Liftgate – Two Piece Platform	13
6	Maximum Load and Placing of Load of Platform:	14
7	Operating Liftgate.....	15
	7.1.1 Control Panel Operation - Switch	15
	7.1.2 Operation by Foot Control	18
	7.1.3 Operation by Push Wireless Hand Held Remote	18
8	Cart Stops Opertation	19
	8.1.1 Single Piece Platform	19
	8.1.2 Two-Piece Platform (Split Platform).....	20
9	Preventive Maintenance and Quick Check	21
	9.1 Maintenance and Care.....	21
	9.2 Lubrication	22
	9.2.1 Lubrication Plan.....	22
	9.2.2 Lubrication Plan – Two-Piece Platform.....	23
	9.3 Checking and Changing Oil	24
	9.3.1 Recommended Hydraulic Fluids.....	24
	9.4 Quick Check List.....	25
10	Troubleshooting	27
	10.1 Basic Function Check	27
	10.1.1 Liftgate is Completely Dead (No Clicking or Movement at all)	27
	10.1.2 Activate Emergency Mode.....	29
	10.1.3 Cab Switch L.E.D.s are on but all functions are dead	29
	10.1.4 L.E.D.s continue to stay on, after switch is turned off	29
	10.1.5 Platform tilts down before it reaches the ground.....	30

10.2 Possible Cause & Remedy of Liftgate Malfunction 31

10.3 Electrical and Hydraulic Schematic 33

 10.3.1 Battery Wiring Diagram 33

 10.3.2 Electrical Schematic 34

 10.3.3 Connector Overview 35

 10.3.4 Hydrualic Schematic..... 36

11 Decal Placement..... 37

12 Required Information for Ordering Spare Parts and Repairs 39

 12.1 Ordering Spare Parts 39

 12.2 Repairs 39

13 Warranty..... 40

14 Contact Address..... 41

Company Information:

Company Name: _____

Advisor Name: _____

Vehicle Year/Make/Model: _____

Liftgate Information:

Liftgate Serial Number: _____

Liftgate Model Number: _____

Date of Purchase: _____

Date of Installation: _____

1 Manual Update

Revision	Description
v1.2	<ul style="list-style-type: none">• Reformatted manual.
v1.3	<ul style="list-style-type: none">• Updated pictorals throughout the manual to reflect current product.
v1.4	<ul style="list-style-type: none">• Added split platform information.
v1.5	<ul style="list-style-type: none">• Update operating instructions (Slim Control Panel)

2 Safety Information

This manual follows the Guidelines set forth in “ANSI Z535.4-2007” for alerting you to possible hazards and their potential severity.

DANGER

! **DANGER** indicates an imminently hazardous situation which, if not avoided, **will result** in death or serious injury.

WARNING

! **WARNING** indicates potentially hazardous situation which, if not avoided, **could result** in death or serious injury.

CAUTION

! **CAUTION** indicates a potentially hazardous situation which, if not avoided, **may result** in minor or moderate injury.

CAUTION

CAUTION without the safety alert symbol is used to address practices not related to personal injury.

(In this manual it is used to alert the user to potentially hazardous situation which, if not avoided, may result in property damage.)

NOTICE

NOTICE without the safety alert symbol is used to address practices not related to personal injury. *(In this manual it is to alert you to special instructions, steps, or procedures.)*

- Always be aware of your surroundings.
- Wear eye protection at all times during installation.
- Ear protection and gloves should be used when necessary.



The maximum loads must be observed and followed!



3 Important Notes

3.1 Attention

Before starting any operations of the liftgate, please read and understand this OWNER'S MANUAL. Its intention is to act as a guide for the operation personal as well as to give help with preventive maintenance but does not take place of unauthorized usage or repair by unqualified personnel.

Please contact your nearest PALFINGER Liftgates distributor or PALFINGER Liftgates in California or New Jersey for assistance if you have questions regarding installation, operation or maintenance.

This owner's manual applies to the following models: **Minifix 1100 / 1320**



This is the safety alert symbol. It is used to alert you to potential personal injury hazards. Obey all safety messages that follow this symbol to avoid possible injury.

3.2 Important Notes

Your PALFINGER Liftgates Minifix is a cargo van lift design, electro-hydraulically driven lift gate.

The Hydraulic Power Unit (HPU) is easily accessible for service and exchange and is placed in a box underneath the Truck.

Lifting actions are carried out by one hydraulic lift cylinder mounted to the lift arm.

The hydraulic tilt cylinder under the platform is controlling the tilting action. This enables the platform to maintain its position throughout the lift mode, regardless of the terrain.

The hydraulic cylinders are equipped with solenoid operated valves located at the port of each cylinder. This prevents the platform from moving unless the operator is activating the controls. This system also enables you to store the lift gate without a separate platform latch.

The piston rods are treated against corrosion and also protected with plastic or rubber boots to protect from road gravel and dirt. The Hydraulic Power Unit is equipped with a built-in pressure relief valve, which prevents overloading when lifting and tilting up.



The valves do not prevent overloading of the platform when lowering or tilting down.



The electric supply is taken from the vehicle battery. If the vehicle battery is not sufficient, an auxiliary battery kit needs to be installed. The electric control power is secured via a 20 Amp fuse and an on-off switch located inside the cab. The switch has L.E.D. lights indicating when the control power is on.

The liftgate is operated from a 3-button outside control which is located on the curbside of your truck. A standard 2-button hand held remote control is also supplied with the lift. A variety of different control options can be purchased with the PALFINGER Liftgates product.

3.3 General Information

REMEMBER!

It is the fleet manager's responsibility to educate the operator on the liftgate and its intended use. The operator's attention should be drawn to the permitted load limits and an understanding of the operation to ensure the safety throughout the operation.

ONE-MAN OPERATION!

Never let an "outsider" operate the liftgate while you are handling the cargo. A "misunderstanding" can result in serious personal injury.



In the interest of safety it is important that all operating personnel properly understand the functions of the liftgate, possible hazards and dangers and the load limits and load positioning for that specific unit.

IMPORTANT NOTICE!



Before the operator uses the liftgate, they should be thoroughly familiar with the lift's functions and usage according to the following:

1. Improper operation of this lift can result in serious personal injury. Do not operate unless you have been properly instructed, have read and are familiar with the operation instructions. If you do not have a copy of the instructions please obtain them from your employer, distributor or lessor, as appropriate, before you attempt to operate the lift.
2. Be certain the vehicle is properly and securely stopped before using the lift.
3. Always inspect this lift for maintenance or damage before using it. If there are signs of improper maintenance, damage to vital parts or slippery platform surface, do not use the lift. Do not attempt your own repairs unless you are specifically trained.
4. Do not overload. See the Rating Label on the unit for the rated load. Remember that this limit applies to both raising and lowering operations.
5. Each load should be placed in a stable position as near as possible to the body of the truck.
6. Never stand in, move through or allow anyone else to stand in or move through the area in which the lift operates, including that area in which a load might fall.
7. This is not a passenger lift. Do not ride the lift with unstable loads or in such a manner that a failure would endanger you. The lift is not equipped with a back-up system to prevent falling cargo in the event of a failure.

3.4 Improper Useage

Some examples of improper use of the liftgate may include, but are not limited to:

- Using the liftgate as an elevating work platform.
- Using the liftgate to push, pull, or low load or other objects.
- Using the liftgate to carry people (Only the operator may travel on the platform)
- Using the liftgate to clear snow
- Trying to use the liftgate as a “launching pad”
- Using force of the hydraulic system to bend, shear, or break objects.
- Driving a forklift over the liftgate.
- Driving the vehicle with the platform open.
- “Plowing” with the platform.

4 Important Information

Before Getting Started

“READ FIRST”

NOTICE

Before starting any operations of the liftgate, please read and understand this Owner's Manual. The intention of this manual is to provide the user a guide for the operation as well as preventive maintenance. Do not attempt to modify or repair the liftgate unless performed by qualified personnel. Please contact your nearest PALFINGER Liftgates distributor or PALFINGER Liftgates in California or New Jersey for assistance if you have any questions regarding installation, operation or maintenance at 888-774-5844.

This owner's manual applies to the following models: **Minifix 1100 / 1320**

Important notes

The electric supply is taken from the vehicle battery. If the vehicle battery is not sufficient, an auxiliary battery kit needs to be installed. The electric control power is secured via a 15-Amp fuse and an on-off switch located inside the cab.

Trailer applications have an on/off switch near the rear curb side corner post.

The liftgate is operated from a push buttons switch. A hand held remote control is standard with up and down functions. A variety of different control options can be purchased with the PALFINGER Liftgates product.



The valves do not prevent overloading of the platform when lowering or tilting down.

WARNING

Improper operation of this liftgate may result in severe personal injury or death. **DO NOT** operate unless you have been properly instructed, have read and are familiar with the procedures in this manual. This manual has been designed to illustrate the steps needed for the basic operation of the Minifix liftgate. It also provides safety information and simple preventive maintenance tips.

NOTICE

This manual is not intended for use as a repair or troubleshooting guide. Repairs should be performed by a PALFINGER Liftgates Authorized Service Center.

This Manual has been designed for use in conjunction with the Minifix series liftgate only which is designed for different capacities and features.

- 1) Refer to the serial number tag on the front of the liftgate mount frame.

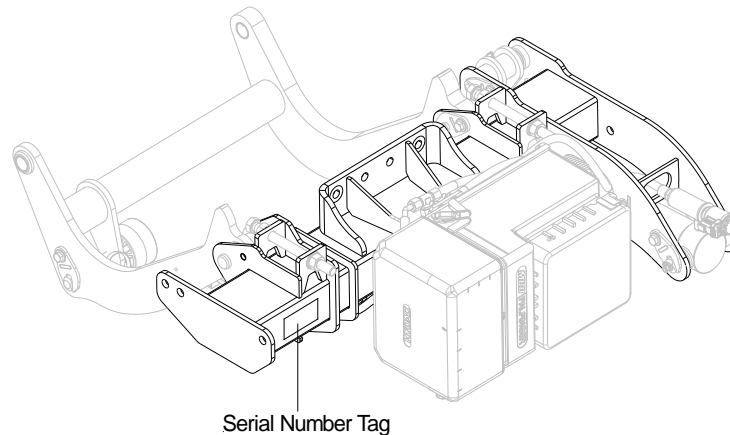

- 2) Ask your employer or lessor;
- 3) Call your Palfinger Liftgates Authorized Service Center for assistance.
- 4) Call Palfinger Liftgates for assistance in the USA at 888-774-5844. You can also contact Palfinger Liftgates by fax (562) 924-8318 or on the internet at www.palfinger.com For technical support, contact Palfinger Liftgates or an authorized Palfinger service center. www.palfinger.com

Please read through the operational and technical description of this PALFINGER Liftgate.

Thank you for choosing PALFINGER Liftgates.

5 General View of Liftgate

5.1 Standard Minifix Liftgate – Single Piece Platform

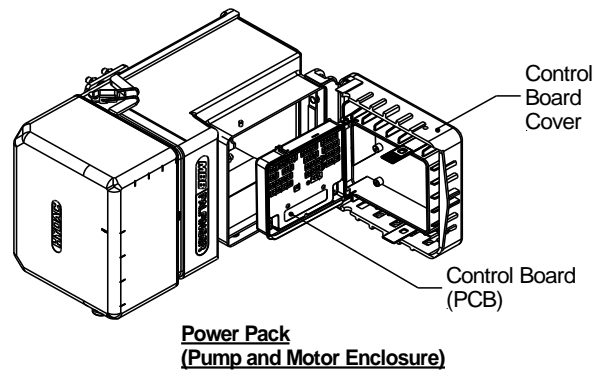
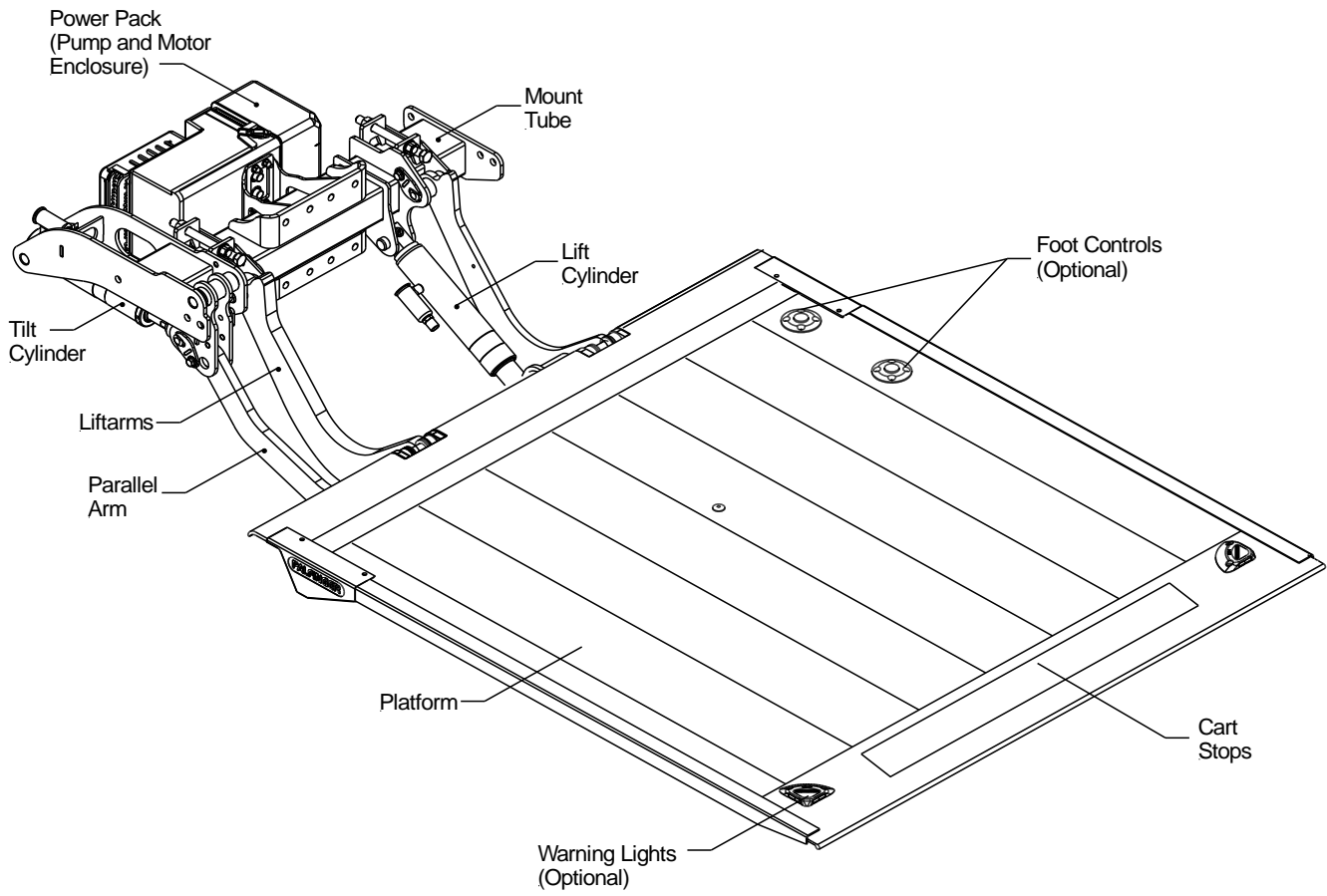

5.2 Split Platform Minifix Liftgate – Two Piece Platform

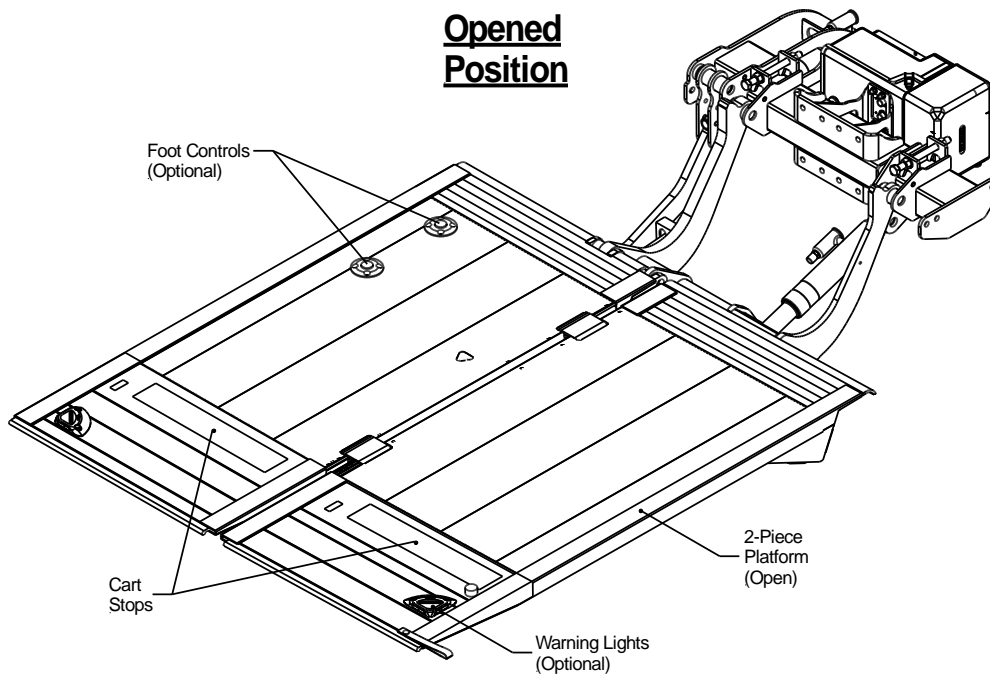
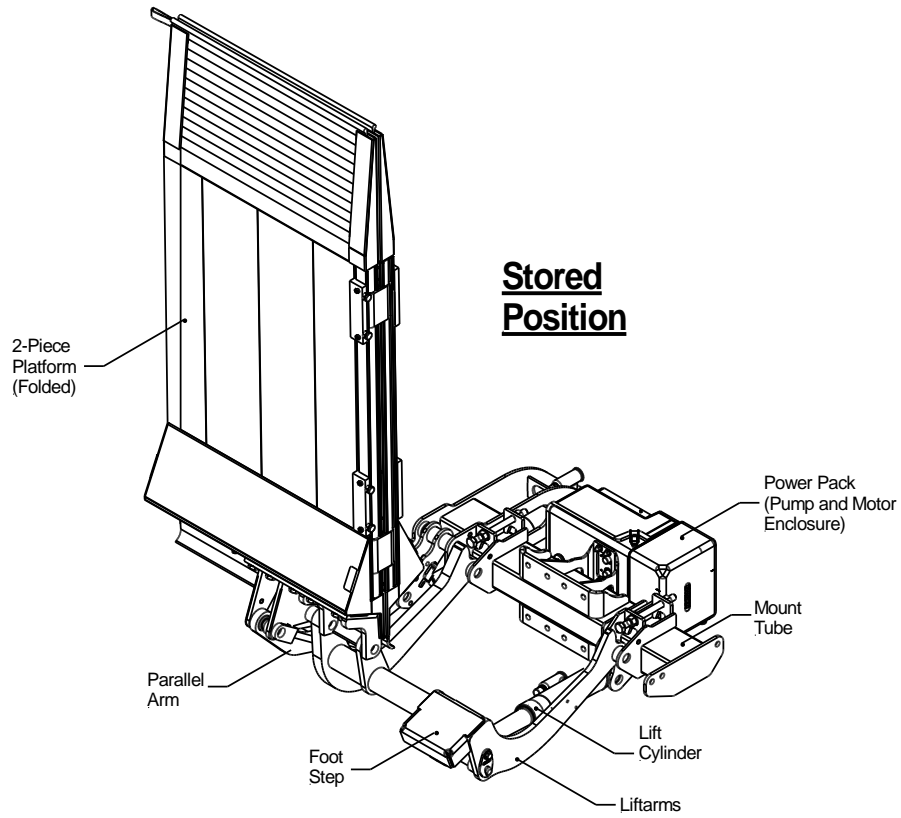

6 Maximum Load and Placing of Load of Platform:

All liftgates are rated up to a maximum load. The point of maximum load is rated at a defined distance. The center point of maximum load is at 24" from start of vehicle body, as shown below.

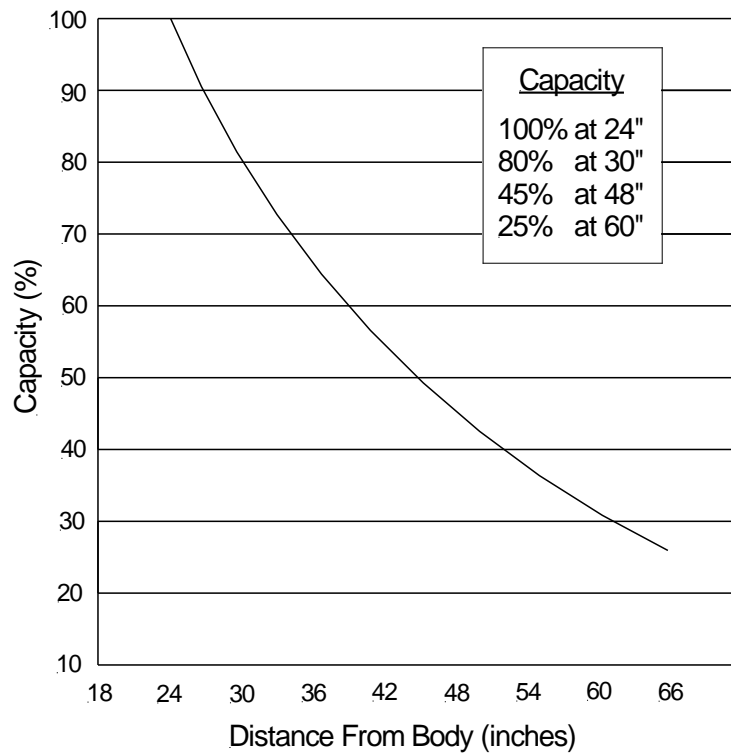
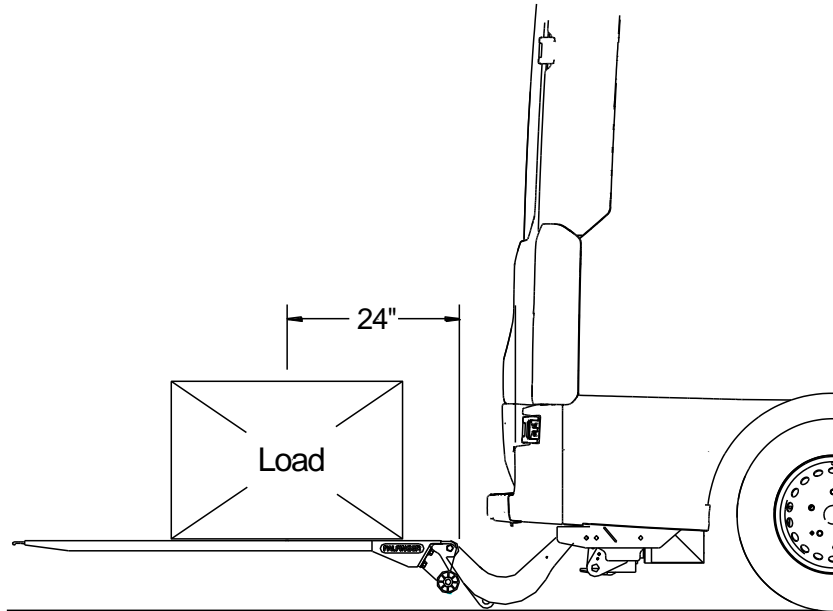

By increasing this distance the maximum load of the liftgate is decreasing. The maximum loads must be observed and followed.

7 Operating Liftgate

 Always observe the platforms operating range when opening. Do not stand in the platforms swiveling range as it can lead to serious injuries.

NOTICE

Operating instructions below are described for Horizontal mounted buttons. If buttons have been installed vertically, follow the Vertical Mounted button operations. Operation of liftgate is the same for Split Platform and Single Piece Platform.

7.1.1 Control Panel Operation - Switch

1. Turn the Control Switch "ON" from inside the vehicle cab. LED lights on the switch should be lit up when the liftgate is ready to use.

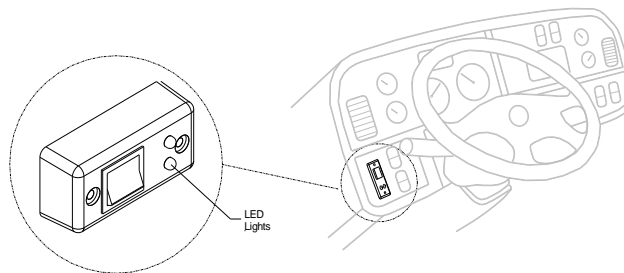

2. From the platforms stored position, using two hands, simultaneously press and hold the **indicated buttons** to open the platform to the horizontal position.

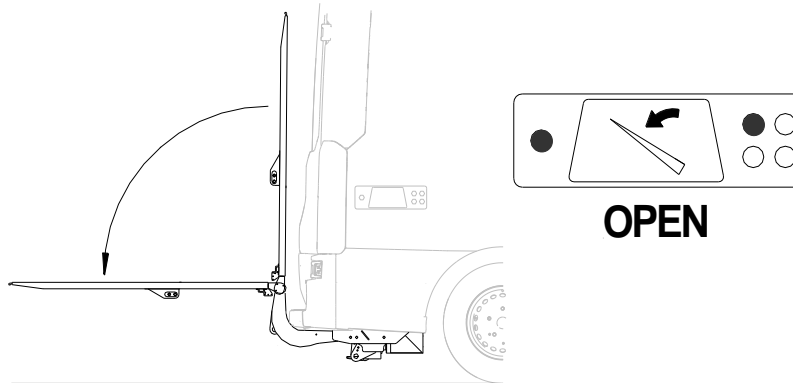

Liftgates with Split Platforms: After opening the platform to the horizontal position, unlock the spring latch located on the left side of the platform. Using the handle pen the split section of the platform strap on the tip section of the platform.

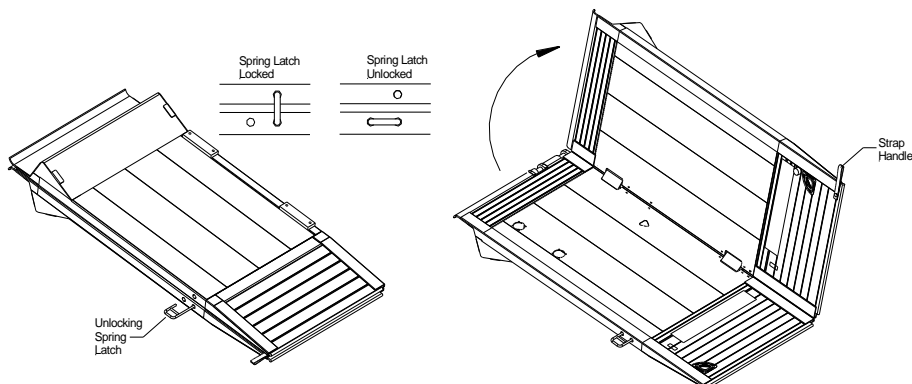

- To lower the platform, simultaneously press and hold the **indicated buttons**. Keep pressing the **indicated buttons** to have the platform tilt down.

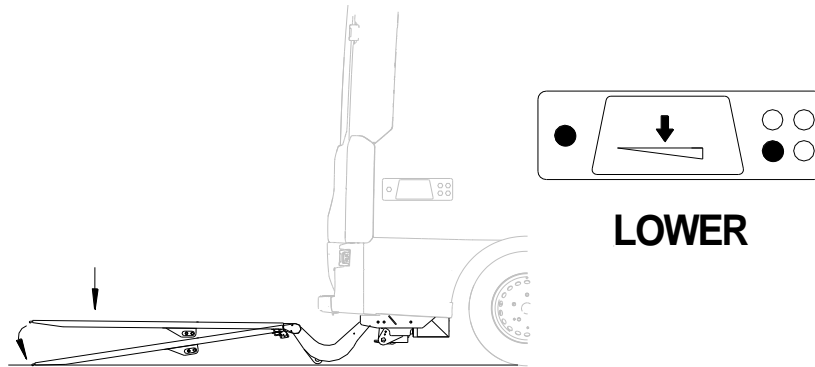

- Open the vehicles rear doors. The platform is ready to load. Center the load at 24" from the front of the platform. Use the 2-Button hand held remote to raise and lower the platform at this point. *The handheld remote is located inside the van on the rear right side.*

Attention: Always be aware of the surroundings and stand 3 feet away when raising and lowering the platform.

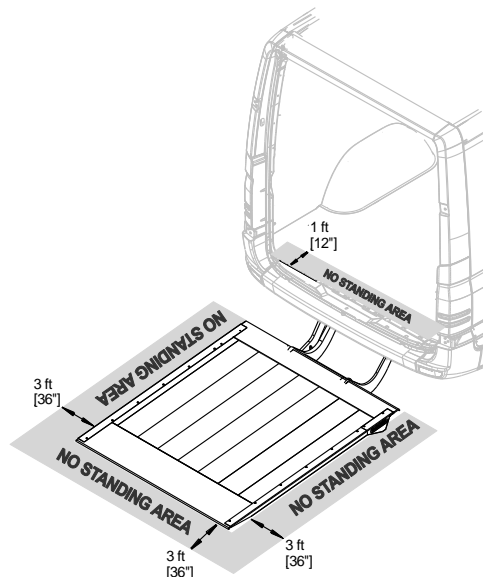
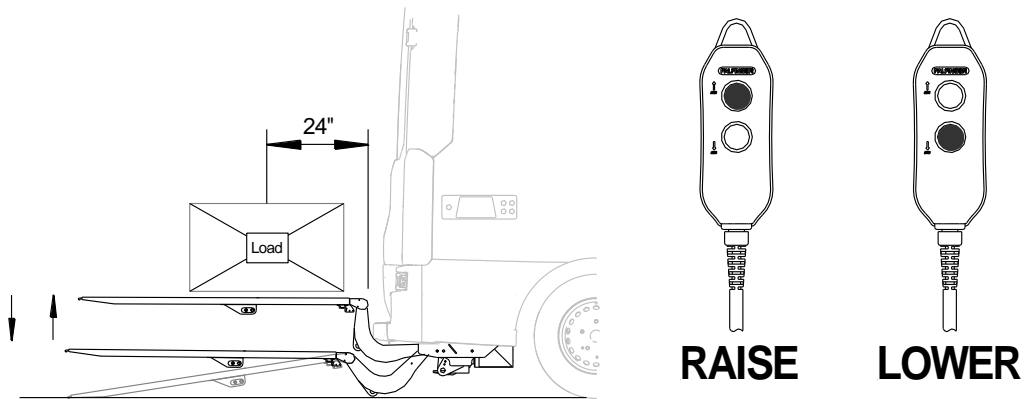

- To store platform, close the vans rear doors. Raise the platform up to bed level. Simultaneously press and hold the **indicated buttons** to raise the platform to bed level.

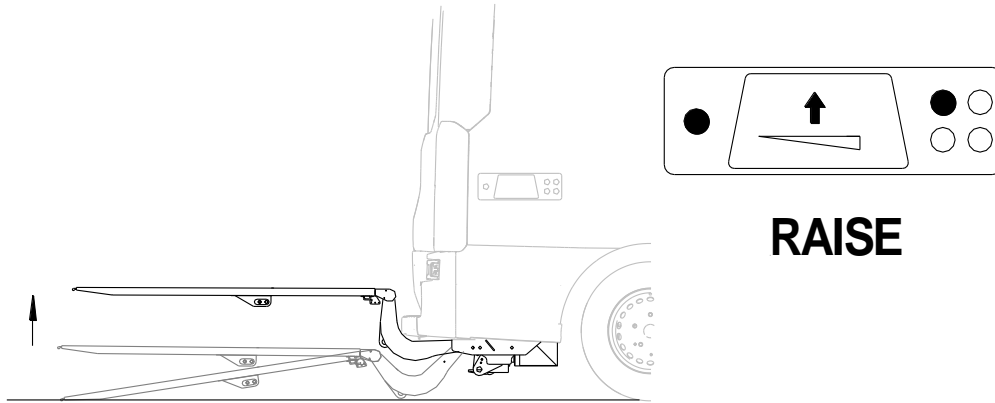

Simultaneously press and hold the **indicated buttons** to raise the platform to bed level.

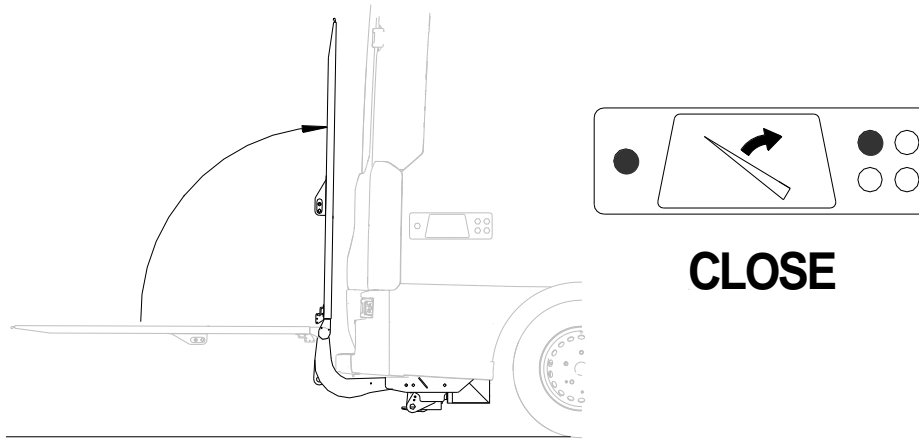

- Power the liftgate off when not in used. The LED should be off when the liftgate is powered off.

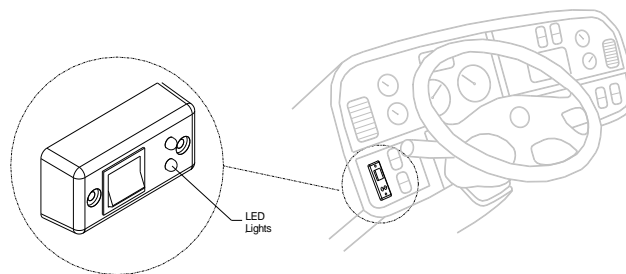

7.1.2 Operation by Foot Control

DOWN:

Step on the front and hold – wait between one and three seconds before you step on the rear switch.
 → For auto tilt, stay on the switches till platform starts tilting.

UP:

Step on the rear switch and hold – wait between one and three seconds before you step on the front switch
 → The platform will tilt up to preset position before rising.

IF BOTH SWITCHES ARE NOT ACTIVATED WITHIN THREE SECONDS, START OVER.

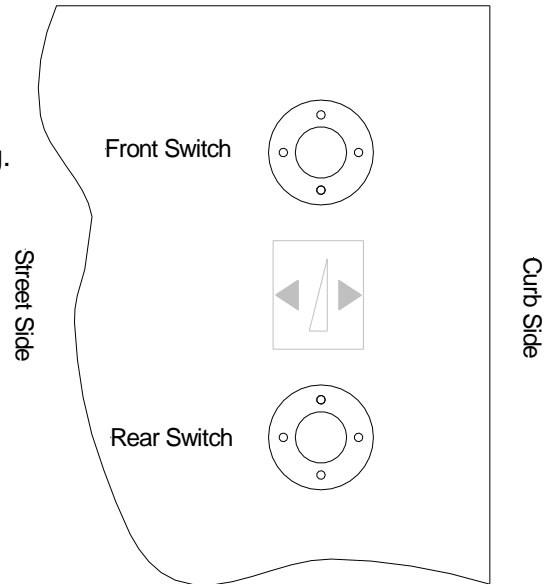

NOTICE: For split platform liftgates the foot control switch orientation does not change.

7.1.3 Operation by Push Wireless Hand Held Remote

1. Power the remote by using the ON/OFF switch on the rear of the control.
2. Each function has a separate button. Functions are displaced as below
3. After finishing using the gate, switch the power off on the remote.

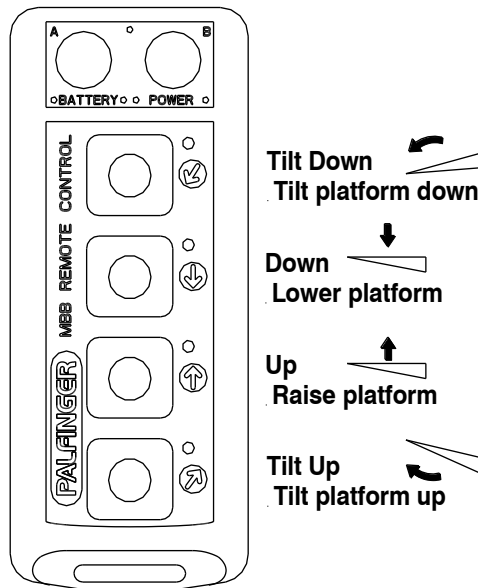

8 Cart Stops Opertation

8.1.1 Single Piece Platform

Steps:

1. Step on the knurled wheel on right side of the platform. Put weight on the foot that's stepping on the knurled wheel and slide the foot back towards the tip of the platform. This will cause the cart stop to spring open. Make sure nothing is on top of the cart stop to prevent it from opening.
2. When finished using the cart stop, simply step on the cart stop panel pushing it down into its chamber.

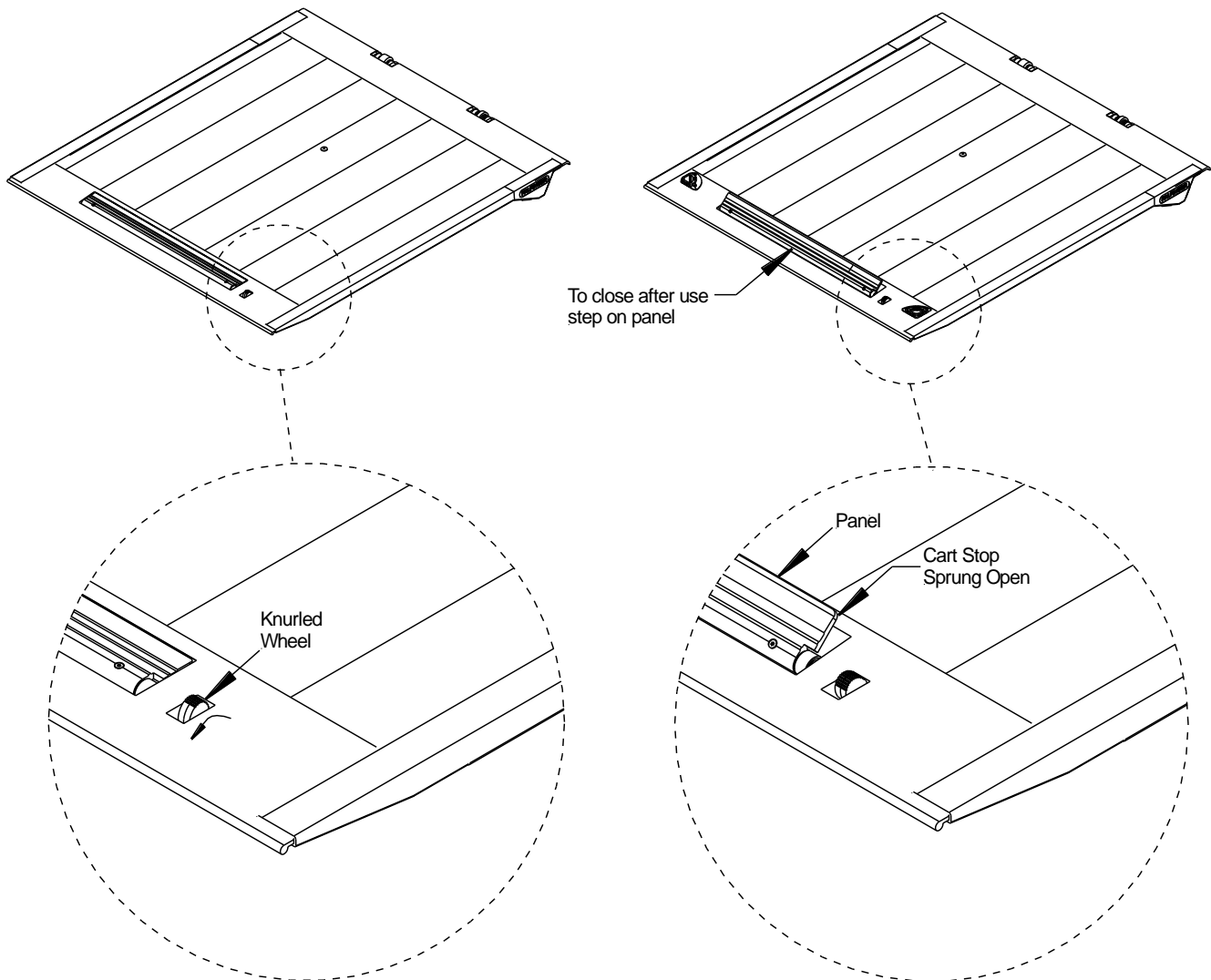

8.1.2 Two-Piece Platform (Split Platform)

Step 1: Lower the gate down to bed level.

Step 2: Unlock the split platform by pulling the spring latch located on the side of the platform. Store the latch on the left section of the platform.

Reminder: Always lock the left and right sections when not in use.

Step 3: Use the strap handle to open the right section of the platform.

Cart Stop Operation

1. Step on the knurled wheel on right side of the platform. Put weight on the foot that's stepping on the knurled wheel and slide the foot back towards the tip of the platform. This will cause the cart stop to spring open. Make sure nothing is on top of the cart stop to prevent it from opening.
2. When finished using the cart stop, simply step on the cart stop panel pushing it down into its chamber.

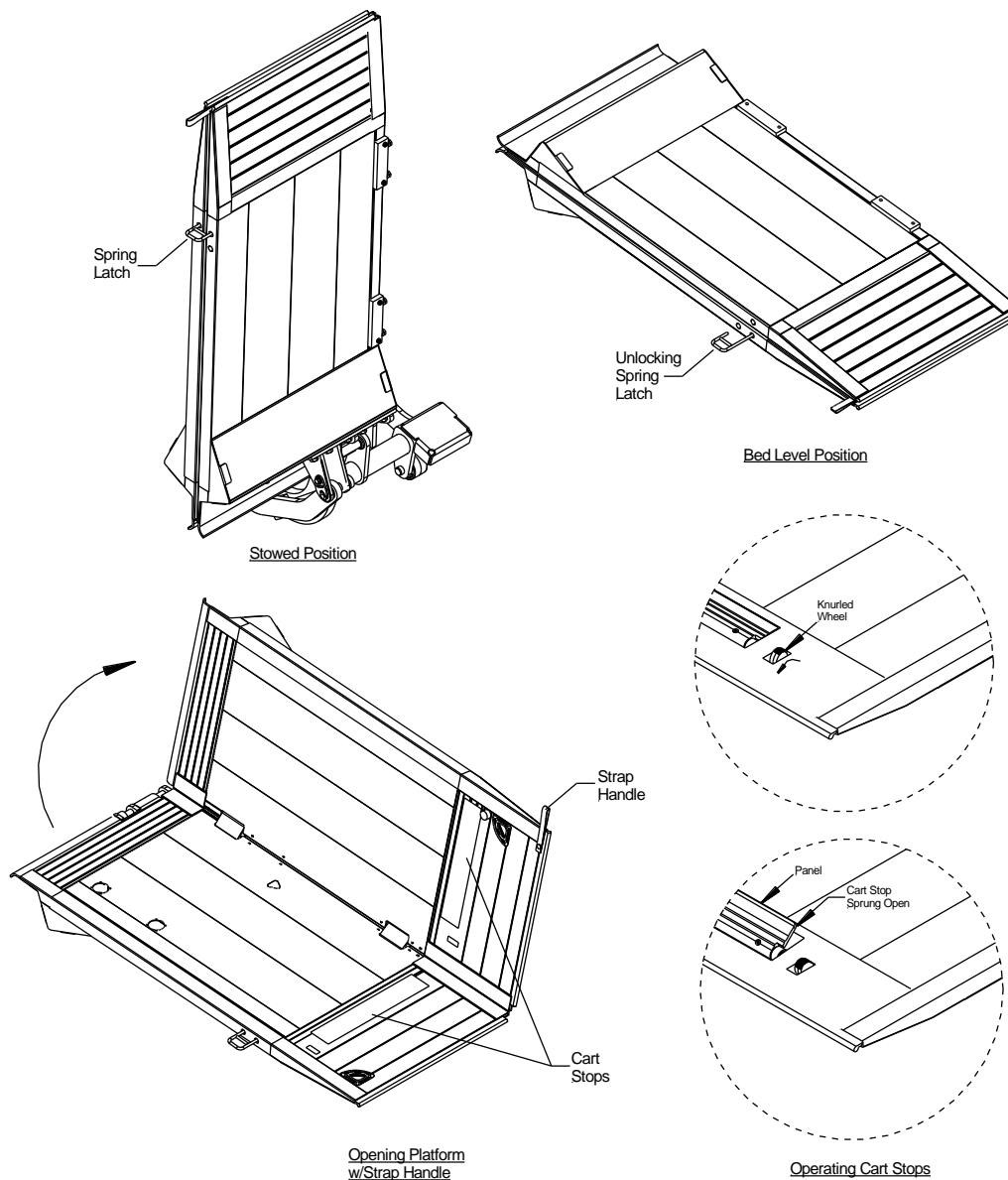

9 Preventive Maintenance and Quick Check

The Minifix needs preventive maintenance to perform at its fullest capacity. Lubricate and inspect regularly. Also check that all details are damaged: Hoses, cables, controls, etc.



REPAIR OR REPLACE IMMEDIATELY FAULTY PARTS



9.1 Maintenance and Care

The following “inspection and maintenance” should be performed at the recommended intervals depending on operation and amount of cycles or at the time when the unit shows any signs of damage or abuse. Remember that the secret to a long life of your PALFINGER Liftgate is to maintain it through preventive care.

* Recommended bases for inspection and maintenance	Depending on use	Daily	Monthly	Quarterly
cleaning	x			
general lubrication of pins and bushings				x
oil level inspection				x
oil change	x			
check hydraulic hoses and pipes for leaks				x
check controls and connections				x
check pins and pin retaining bolts			x	
check batteries and connections				x
check warning labels and other safety equipment for effectiveness and visibility		x		
visual check for loose or missing parts and un-usual noise during operation		x		
check lock bolts and pins for tightness				x
check complete function of gate		x		
check mounting brackets of lift gate to frame for cracks or damage visually		x		

NOTICE

All parts except the chrome-coated piston rods, the push buttons, solenoids valves, foot controls and warning lights can be cleaned by means of a water jet.

9.2 Lubrication

Properly lubricated, the PALFINGER Liftgates Minifix liftgate will ensure longevity. Therefore, lubricate the lift at the same time as the truck. Grease more frequently if the liftgate is heavily used. The liftgate should be greased every 1200 cycles (depending on use – estimated every 3 month).

9.2.1 Lubrication Plan

All bearing points must be lubricated in accordance with the maintenance intervals.

1. Lower the platform to the ground.
2. Unclamp the two latches on top and bottom of reservoir. Remove the cover slowly.
3. Remove the reservoirs filler cap. Add the fluid. To drain fluid, remove the cap at the bottom of the reservoir.
4. Wipe any excess grease and replace all red protector caps on zerks.

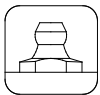
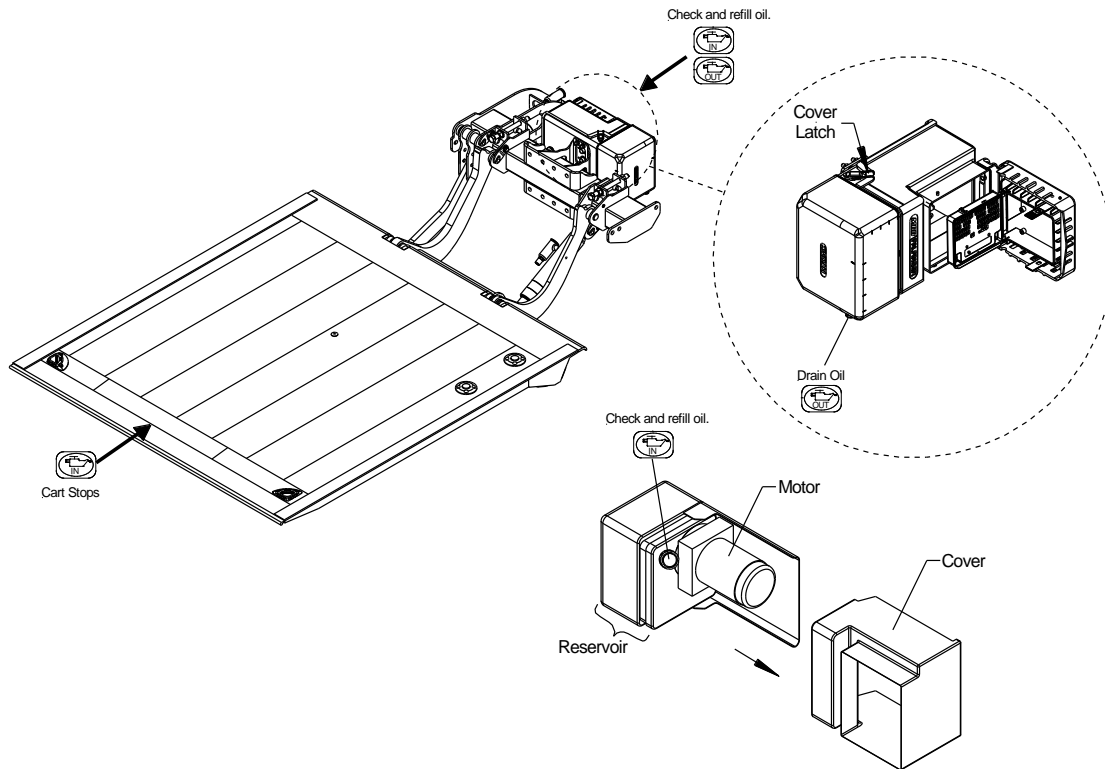

Grease: Location of Grease Zerks

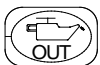
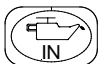

Oil: Oil Level in the power pack tank

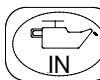

Lubrication: Cart Stops (use WD-40 spray for lubrication).

9.2.2 Lubrication Plan – Two-Piece Platform

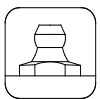
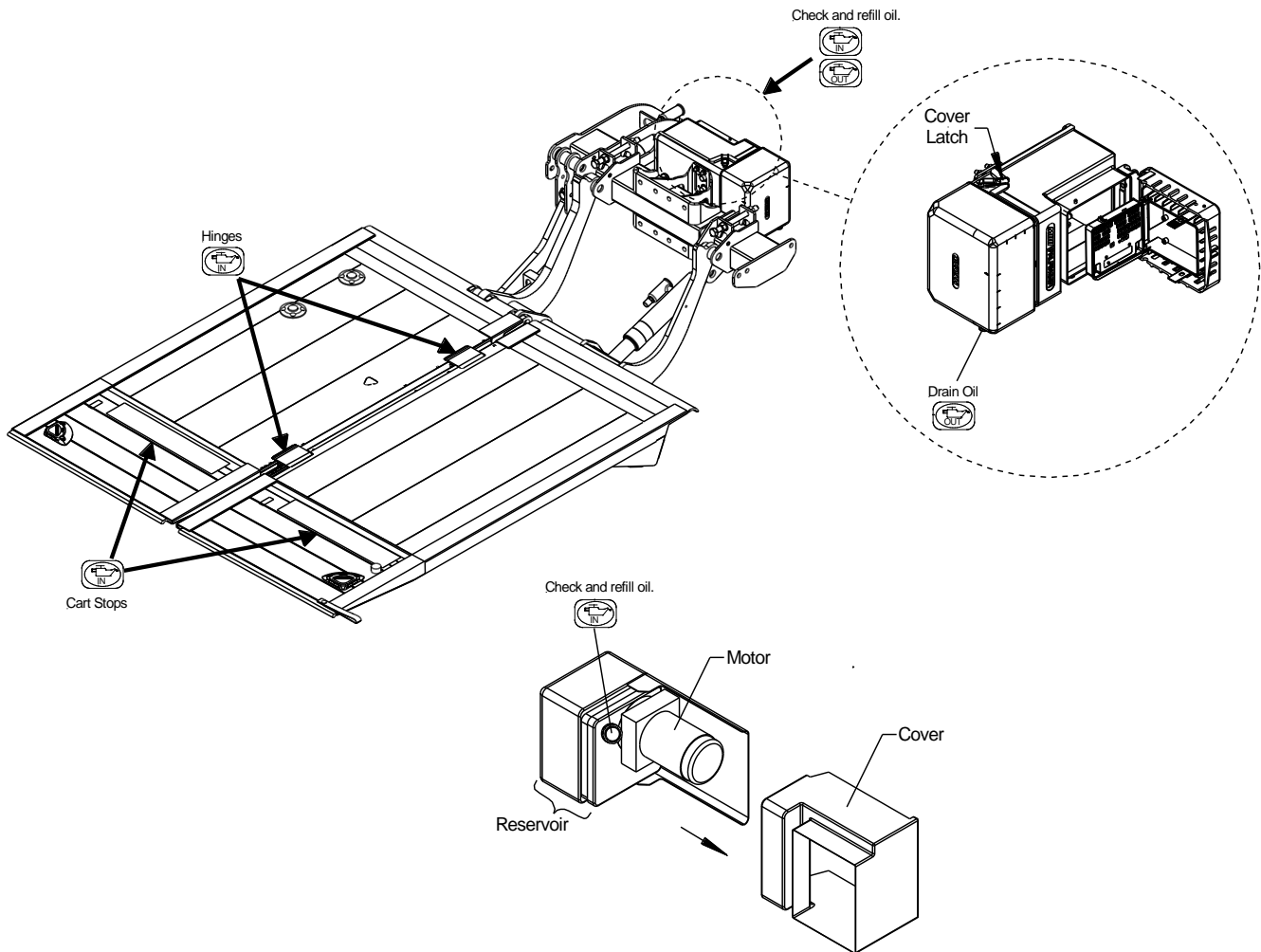

Grease: Location of Grease Zerks

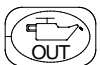
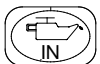

Oil: Oil Level in the power pack tank

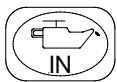

Lubrication: Cart Stops (use WD-40 spray for lubrication).

9.3 Checking and Changing Oil

Check the quality of hydraulic fluid. If bad, take the following steps to change the oil.

Checking Oil:

1. Lower gate to ground and tilt platform down. Open the power pack, so you can reach the oil filler cap. Wires will be connected to the motor so remove the cover slowly.

Changing Oil:

2. Unscrew the oil drainage bolt (bottom of tray) and let the fluid drain out of the reservoir into an approved container.

If the reservoir is empty fill it up with recommended hydraulic oil, as shown on 8.3.1. The oil level must be within the marked limits at the oil tank or dipstick (see indication at oil tank or dipstick).

After filling, the liftgate must be opened and the oil level topped up if necessary.

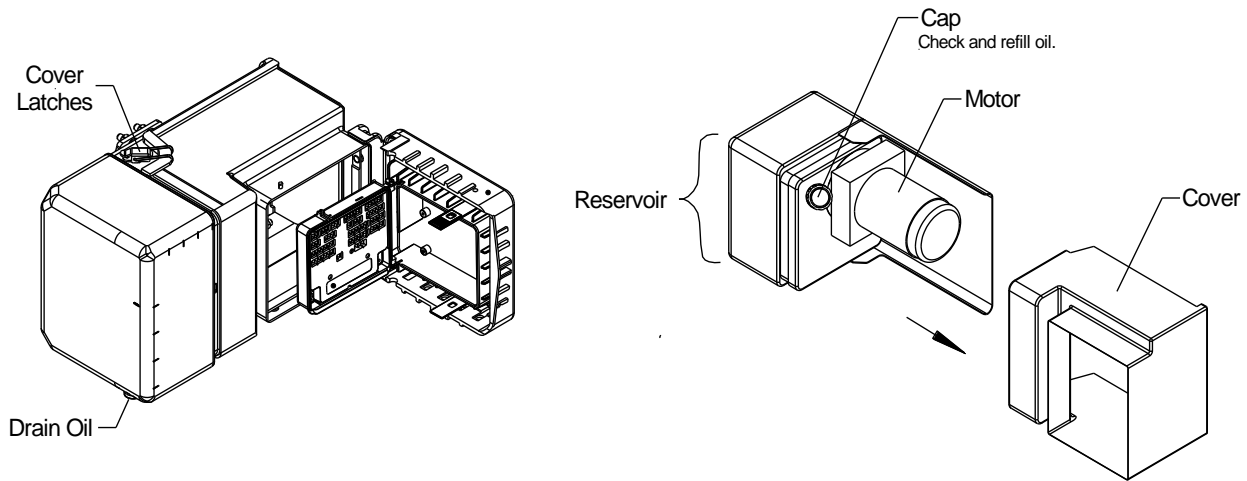

9.3.1 Recommended Hydraulic Fluids

<u>TEMP. RANGE</u>	<u>BRAND</u>	
-10 TO 150 F	EXXON	UNIVIS J26
	MOBIL OIL	DTE 13M
	CHEVRON	AW MV32
	ROSEMEAD	MV 150 (32)
-50 TO 150 F	MOBIL	DTE 13M
	SHELL	AERO FLUID 4
EXTREME COLD TEMPERATURE:	USE MILITARY SPEC:	MIL H5606

9.4 Quick Check List

1. Operate the lift gate throughout its entire operation and check for noise and damage such as bent parts or cracked welds.
2. Inspect all welds and fasteners that attach the mount frame to the truck. All pins and bolts that connect the lift arm to the mount frame and to the platform.
3. Visually inspect the hydraulic lines for damage, scratches, bending or leakage.
4. Inspect the cylinders for leakage and that the cylinder pins are secured with lock bolts.
5. Check the oil level when the platform is down at ground level. The level should fall between the markings on the tank. We recommend replacing oil after the first 1200 cycles, after that on a yearly basis in the fall before winter begins.
6. Check for oil leakage around the power pack and inside mount tube. Tighten or replace components if needed. If you perform work on any hydraulic components bleed the air out of the system by operating all functions several times.
7. Check all electrical connections. Clean and protect battery terminals and check for tightness.
8. Inspect all the terminals on the solenoid-operated valves at the port of the cylinder. Lubricate the terminals for better protection from oxidation if needed.
9. Grease all zerks on the lift gate and make sure they all take grease. Sometimes it helps to operate the lift gate while you do this.
10. Test all the lift gate functions, if possible with maximum loads placed according to load diagrams.
11. Check the function of the pressure relief valve.
12. When doing daily checks and you find any kind of damage that can make the use of the liftgate dangerous, it must be repaired before using. All repairs should be made by an authorized technician. Use only original spare parts. If in doubt contact your PALFINGER Liftgates distributor or call PALFINGER Liftgates directly.



Do not cover up any accidents or damage; it can be dangerous for you and your co-workers.

NOTES

10 Troubleshooting

CAUTION

ATTENTION:



Serious injuries and damages are possible from tools short circuiting main battery connections.



Please check the following points before looking for faults:

- Please change oil after working on hydraulic unit (removal of valves, opening of cylinder etc.).
- There is a possibility of injury if somebody other than an authorized technician works on the electrical system.

10.1 Basic Function Check

10.1.1 Liftgate is Completely Dead (No Clicking or Movement at all)

1. Check the cab shut off switch.

Turn on cab switch, located in the cab next to the steering wheel. Location may vary by model and year of truck. Switch has L.E.D. lights: they should stay on continuously.

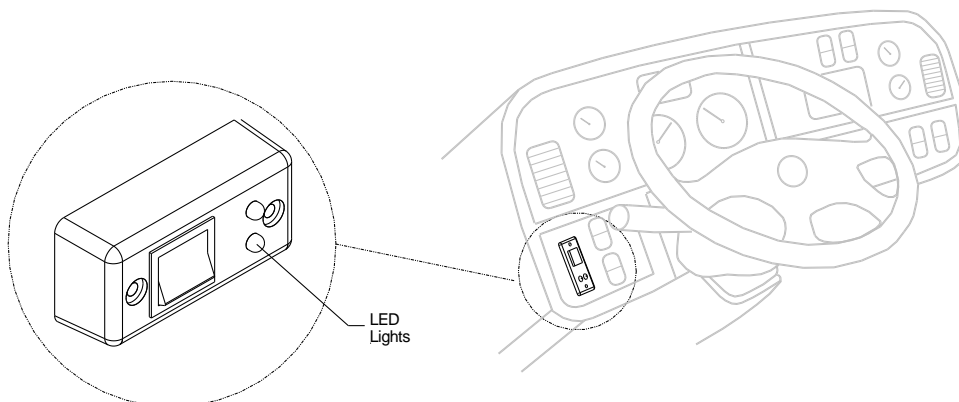

2. Check the circuit breaker at the main batteries.

Every vehicle has a circuit breaker on top of the main battery and fuse. Check if circuit breaker reset arm is popped out, push it back in as shown on the decal ATG-BKR next to your breaker or on battery box lid. Also verify the fuse inside the fuse holder is not broken.

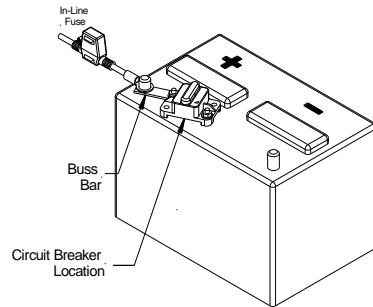

Battery Mount Resettable Circuit Breaker

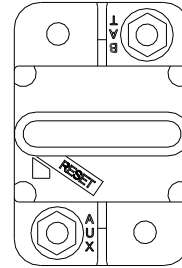

Reset Required when Tab is Exposed

3. Are the vehicle batteries charged?

Check batteries and the truck charging system. Start truck and run engine in fast idle for charging the batteries. If liftgate starts working, recharge batteries.

4. Check the fuses in the power pack.

In the Hydraulic Power Unit next to the motor you will find 2 fuses. Check for burned fuse and replace it with the same type.

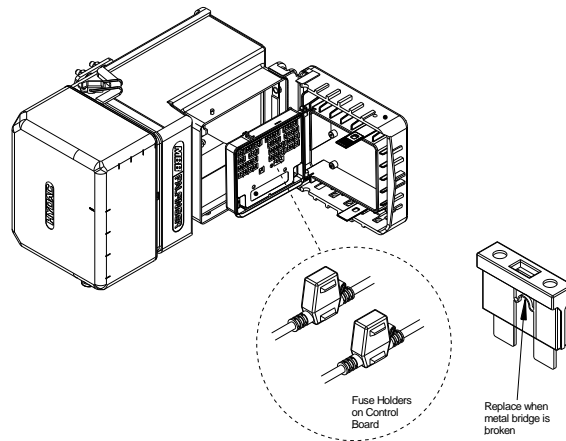

In-Line ATC Fuse 15 Amp at Control Board. **Replace with same amperage fuse when necessary.**

In-Line ATC Fuse: 20 Amp at Battery. **Replace with same amperage fuse when necessary.**

NOTICE: DO NOT attempt to jump in-line fuses with other objects other than the specified fuse(s).

DO NOT increase the amperage rating of fuse. Serious harm to the liftgate will result when standard practices are not followed.

5. Is the connection to ground in power pack OK?

Is the ground connection from the liftgate to vehicle OK?

6. Check the oil level in the power pack reservoir.

7. Are there any damages on mechanical or electrical parts (such as damaged cables)?

10.1.2 Activate Emergency Mode

When Emergency mode is activated, the liftgate sensors are bypassed and can help detect if the liftgate is not operating due to the sensor or something other than the sensors. To activate Emergency Mode Press and hold the Open and Lower buttons simultaneously for approximately 10 seconds. An "E" on the control board will indicate when the liftgate is in Emergency Mode. To inactivate Emergency Mode, power the liftgate OFF and ON.

10.1.3 Cab Switch L.E.D.s are on but all functions are dead

Possible malfunctions:

1. Short in hand held remote or its wire → remove plug J-31.
2. Short in push button switches wire → remove plug J-30.

After disconnecting plugs – reboot board by unplugging J-1 for 5 seconds and plug it back.

10.1.4 L.E.D.s continue to stay on, after switch is turned off

- Make sure platform is closed and stored vertically.
- Adjust the B-16 switch.
- Follow this instruction if B-16 IS NOT working:
 - a) Unplug J-3(w/l and f/c), J-41(B-13, B16) and J-31(Hand control), **jump J-11 #4 to J-41 #GN**
Keep the 3 connectors unplugged (gate will operate without plugs connected, loose auto tilt).
 - b) Unplug J-1 (Main power), wait 10 seconds and plug J-1 back to the board (Reset the board).
 - c) Plug each connector back, one at a time and check functions of gate after plugging in each.

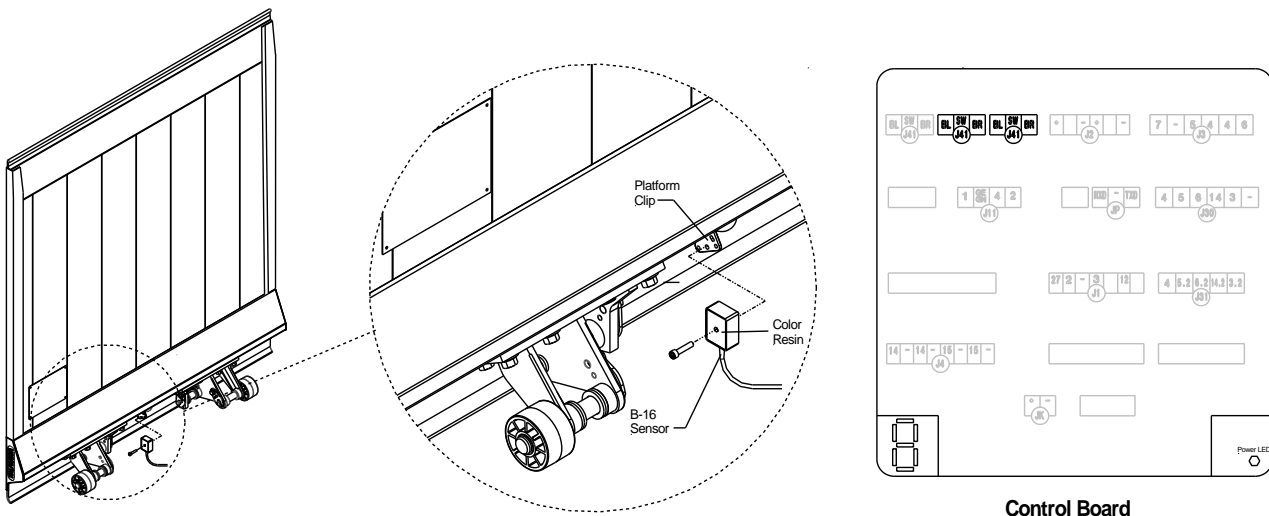

10.1.5 Platform tilts down before it reaches the ground

- Adjust B-13 lift arm switch.
- B-13 is not working → unplug J-41 (gate operates without sensor but loses auto-tilt).

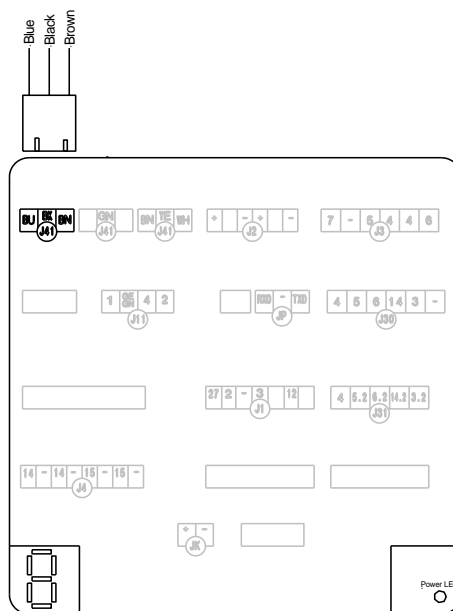
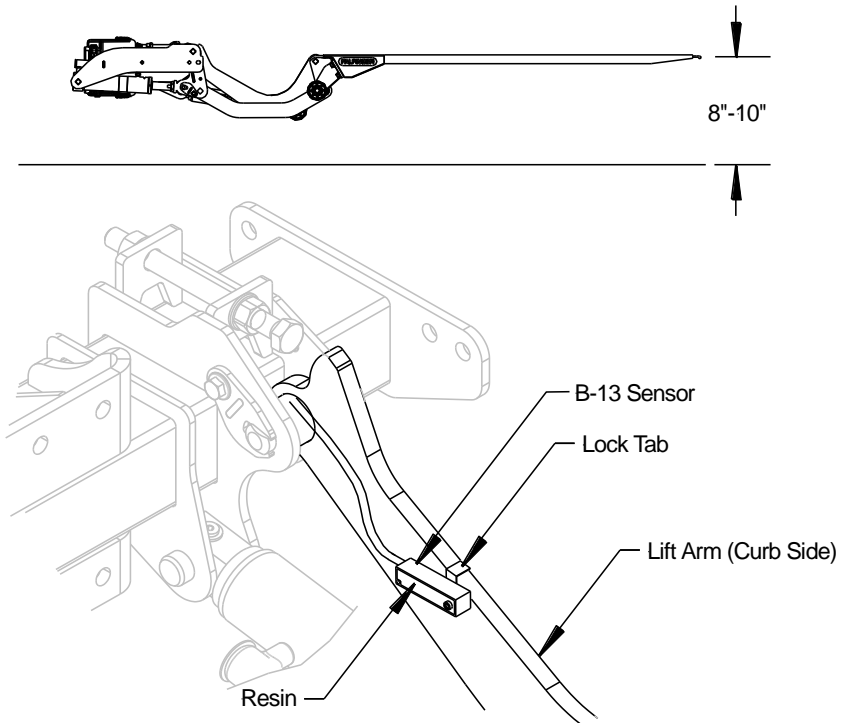

Control Board

10.2 Possible Cause & Remedy of Liftgate Malfunction

FAULT	POSSIBLE CAUSE	REMEDY
Red warning lights do not flash when starting up	<ol style="list-style-type: none"> 1. Control Device is defective 2. PC-Board is defective 	<ol style="list-style-type: none"> 1. Replace 2. Replace
Warning lights do not flash when platform opens (if equipped)	<ol style="list-style-type: none"> 1. Tilt angle of sensor B16 is defective 2. PC-Board is defective 3. Motor is defective 	<ol style="list-style-type: none"> 1. Replace 2. Replace 3. Replace
Power Pack does not run when opening function activated	<ol style="list-style-type: none"> 1. Push button does not give any contact 2. Motor contactor is defective 3. Motor is defective 	<ol style="list-style-type: none"> 1. Replace 2. Replace 3. Replace
Motor starts up but platform does not open	<ol style="list-style-type: none"> 1. Solenoid valve S3 on Tilting Cylinder does not open 2. Control Valve S5 or Shuttle Valve jams 	<ol style="list-style-type: none"> 1. Clean or Replace 2. Clean or Replace
Platform opens too slowly or does not open to horizontal position	<ol style="list-style-type: none"> 1. Flow control valve R4 jam or defective 2. Electric motor malfunctioning 3. Control valve S5 or shuttle valve jams or defective 4. Hydraulic oil too thick 5. Bearings mechanical jamming 	<ol style="list-style-type: none"> 1. Clean or Replace 2. Check Collector and replace carbon brushes if necessary 3. Clean or Replace 4. Change oil as recommended 5. Lubricate bearing points
Platform tilts during lowering operation (before reaching the ground)	<ol style="list-style-type: none"> 1. Tilt angle of B13 Sensor is incorrectly adjusted 	<ol style="list-style-type: none"> 1. To set the time of tilting, tilt the angle on B13 counter-clockwise to start the tilting procedure later.
Platform tilts on its own	<ol style="list-style-type: none"> 1. Solenoid valve S3 on tilting Cylinder soiled or defective 2. Piston seal in tilting Cylinder is defective 	<ol style="list-style-type: none"> 1. Clean or Replace 2. Replace
Platform lowers on its own	<ol style="list-style-type: none"> 1. Solenoid valve S1 on lifting Cylinder soiled or defective 	<ol style="list-style-type: none"> 1. Clean or Replace

Platform does not tilt or very unsteadily after reaching the ground	<ol style="list-style-type: none"> 1. Flow valve R5 or shuttle valve jam or defective 2. Tilt angle switch B13 is adjusted incorrect or defective 3. PC-Board is defective 4. Solenoid valve S3 on tilting Cylinder soiled or defective 	<ol style="list-style-type: none"> 1. Adjust or Replace 2. B13 Sensor is defective or its tilt angle is incorrectly set 3. Replace 4. Clean or Replace
Platform does not tilt or lift at lifting mode	<ol style="list-style-type: none"> 1. Operating buttons or switches, foot or remote control is defective 	<ol style="list-style-type: none"> 1. Replace defective Parts
Platform lifts but does not tilt at lifting mode	<ol style="list-style-type: none"> 1. Directional valve S5 jams or is defective 2. Tilt angle Sensor B16 is defective 	<ol style="list-style-type: none"> 1. Clean or defective 2. Replace
Platform tips further in lifting mode that preset	<ol style="list-style-type: none"> 1. Tilt angle sensor B16 is defective 2. Directional valve S5 jams or defective 	<ol style="list-style-type: none"> 1. Replace 2. Clean or Replace
Platform does not lift, even the hydraulic unit is running	<ol style="list-style-type: none"> 1. Directional valve S5 jams or is defective 2. Solenoid valve S1 on lifting Cylinder is soiled or defective 3. Suction Filter on pump soiled 4. Platform overloaded 5. Hydraulic pump is defective 6. Electrical motor is defective 7. Shuttle valve soiled or defective 8. Pressure control valve incorrectly set or defective 	<ol style="list-style-type: none"> 1. Clean or Replace 2. Clean or Replace 3. Clean or Replace 4. Reduce load in accordance with the load table 5. Replace pump 6. Replace motor 7. Clean or Replace 8. Reset and lead or Replace
Platform does not close	<ol style="list-style-type: none"> 1. Directional valve S5 jams or defective 	<ol style="list-style-type: none"> 1. Replace defective Parts

10.3 Electrical and Hydraulic Schematic

10.3.1 Battery Wiring Diagram

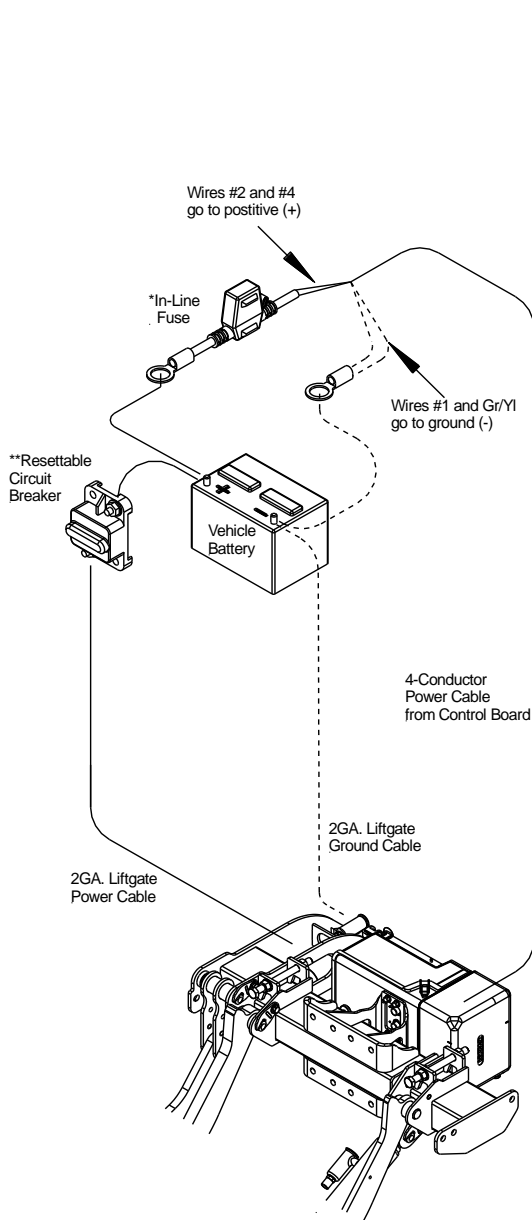

Battery Wiring without Auxiliary Battery Kit

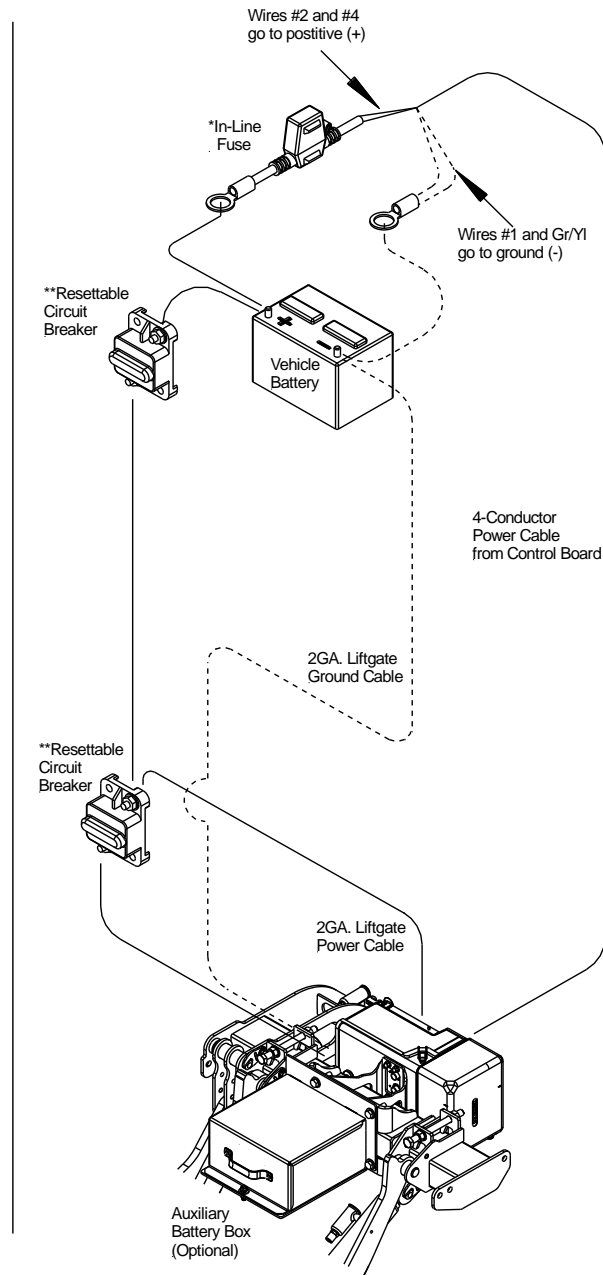

Battery Wiring with Auxiliary Battery Kit

*In-Line ATC Fuse: 20 Amp. **Replace with same amperage fuse when necessary.**

Resettable Circuit Breaker: 150 Amp Min. **Replace with same amperage breaker when necessary.

***Ground: For optimal grounding, ground all batteries and power units to the body side rails of the vehicle.

NOTICE: DO NOT attempt to jump in-line fuses with other objects other than the specified fuse.

Do not increase the amperage rating of fuse. Serious harm to the liftgate will result when standard practices are not followed.

10.3.2 Electrical Schematic

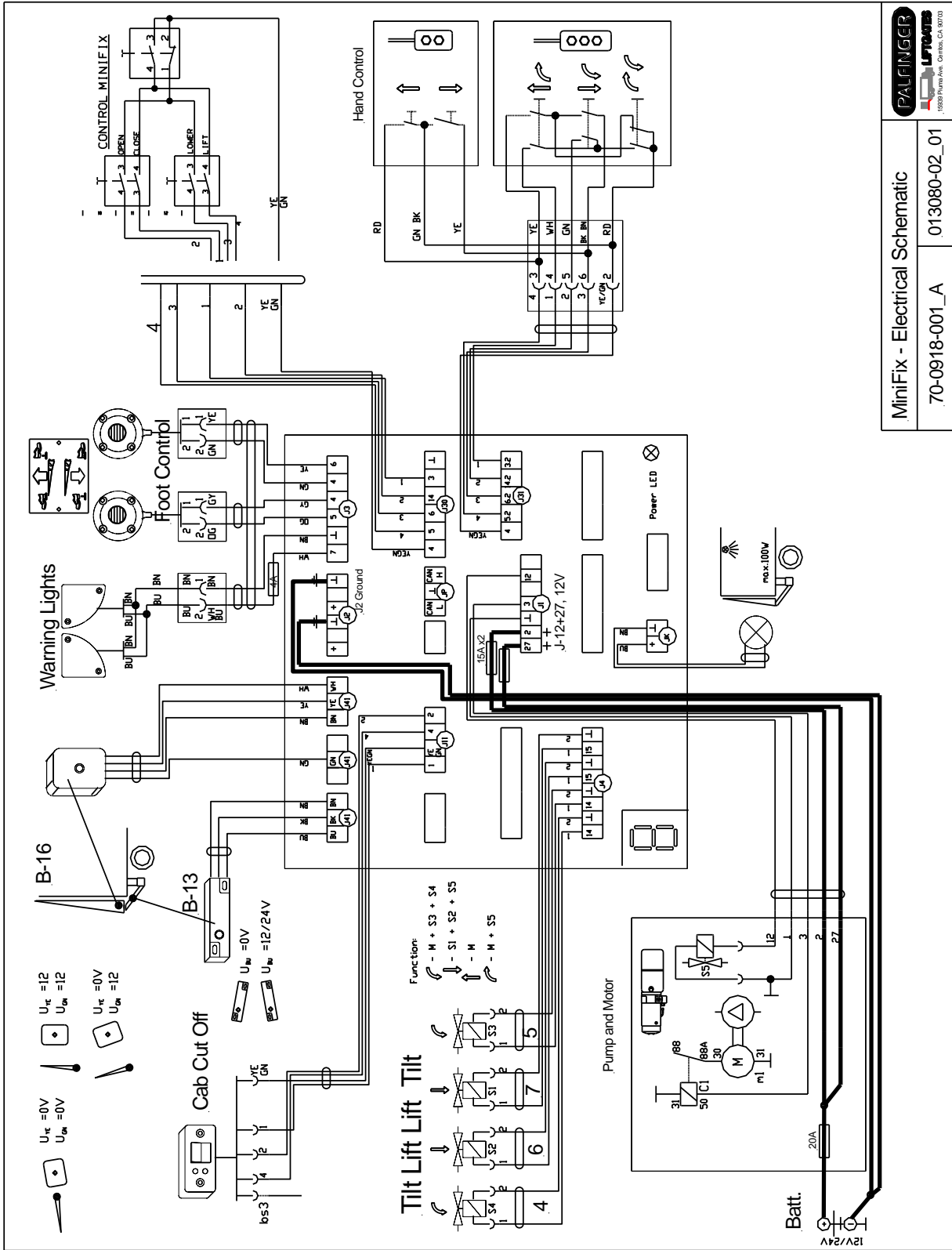

PALFINGER
 15930 Palmdale Ave., Palmdale, CA 91357
UNIFIX

MiniFix - Electrical Schematic
 70-0918-001_A 013080-02_01

10.3.3 Connector Overview

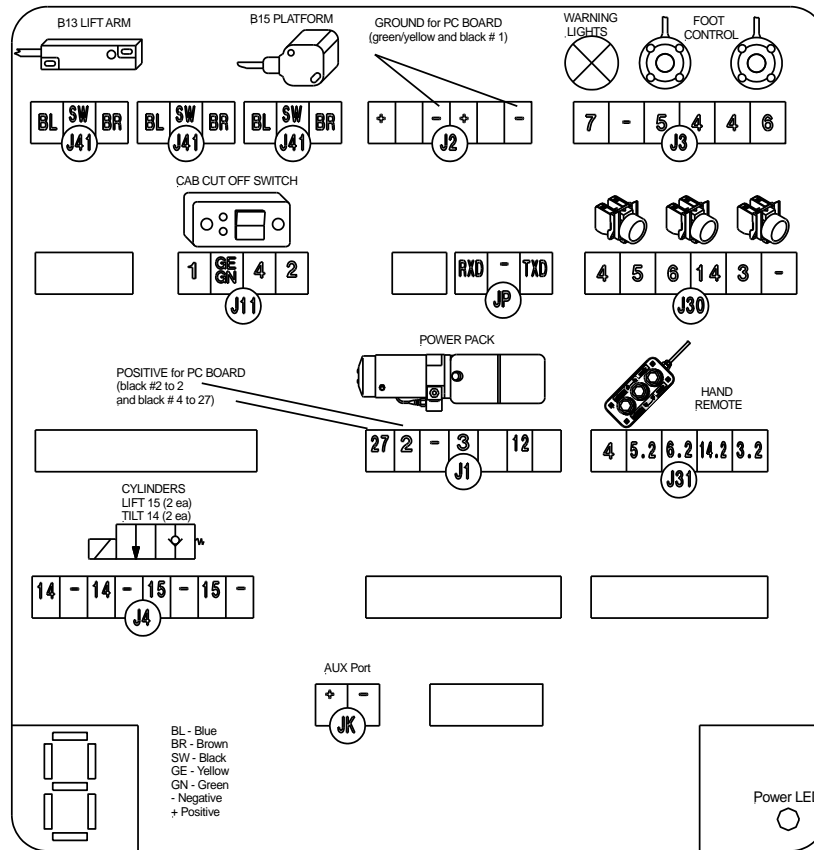

Control Board Codes:

Code	Description	Reset
00	System ok / Cab switch off, (or missing bridge J11/2<->4)	
01	System ok / Cab switch on, (or bridge J11/2<->4)	
02	Low Voltage	Cab switch: off/on (or disconnect bridge J11/2<->4)
03	Missing tilt switch B-13 at lift arm or defective.	Automatically when the valves are back to normal
04	Missing tilt angle sensor B-15 at lift platform or defective	Automatically when the valves are back to normal
05	Missing tilt angle sensor B-15 at platform or defective	Automatically when the valves are back to normal
06	Warning lights shorted	Cab switch: off/on (or disconnect bridge J11/2<->4) or close tail lift
07	Short in cab switch/on-off switch or aux port	Cab switch: off/on (or disconnect bridge J11/2<->4) or close tail lift
08	General short in electrical wiring	Cab switch: off/on (or disconnect bridge J11/2<->4) or voltage interruption MBB control
09	Defect at motor solenoid detected during lifting	Automatically when the valves are back to normal
0A	Voltage V02 (J1 pin 2) is missing, defective fuse	Replace the fuse
0B	Defect at opening, valve (S3/S4) or motor relay detected during opening	Automatically when the valves are back to normal
0C	S5 valve detected during closing or motor solenoid defective	Automatically when the valves are back to normal
0D	S5 valve detected or defect at lowering valve (S1/S2)	Automatically when the valves are back to normal
0E	Emergency program (all sensors are bypassed). Activation by: Press Open+Lower>10 seconds	Cab switch: off/on (or disconnect bridge J11/2<->4)
0F	Diagnosis mode activated	Removing service connector

10.3.4 Hydraulic Schematic

Functions:

- S1 = Release Valve for lowering function
- S2 = Release Valve for tilt down function
- R1 = Flow Restrictor located inside hose adaptor on lift cylinder
- R2 = Flow Restrictor located inside hose adaptor on tilt cylinder
- S5 = Shift Valve is activated on tilt up and lowering function
- R5 = Restrictor Valve located in power pack
- Flow Divider is activated, when fluid is going back into the power pack
- If Flow Divider is loose or hanging up the fluid is circulated back in to tank

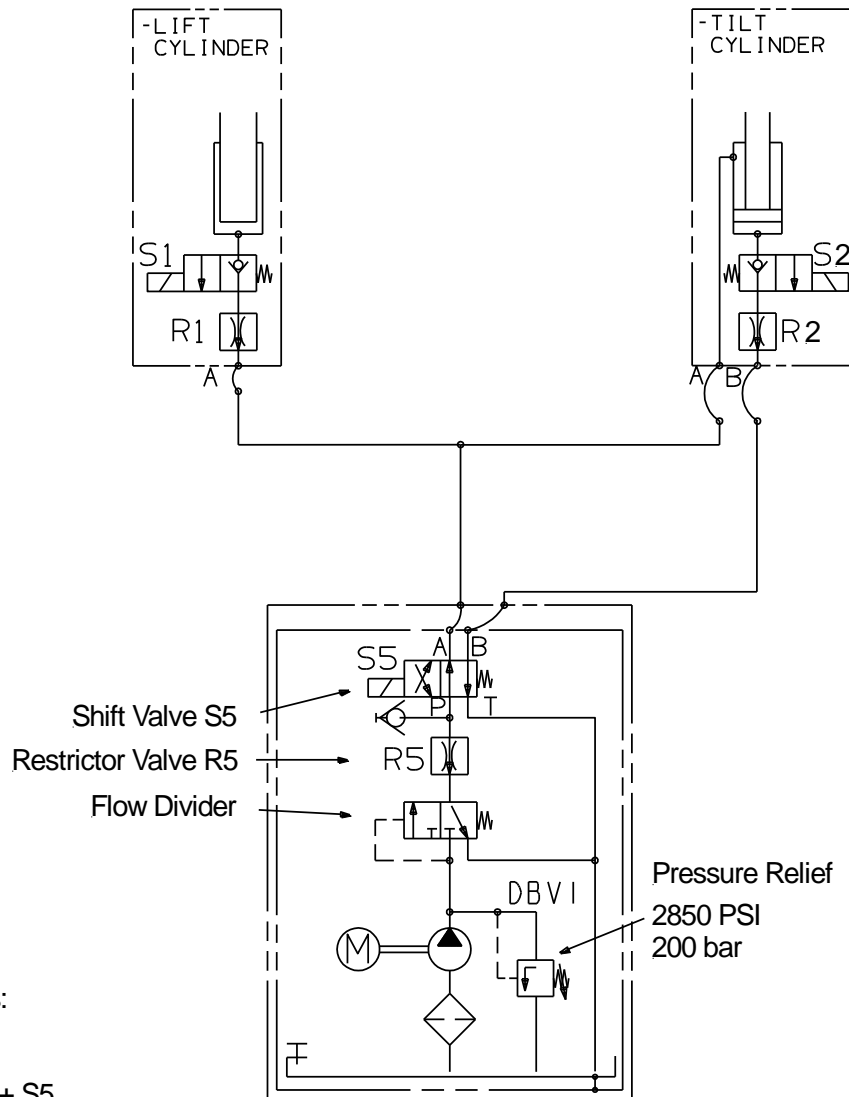

Functions:

- Lift: M
- Lower: S1+ S5
- Tilt Up: M+S5
- Tilt Down: S2
- Horiz. Open: M+S2

MiniFix - Hydraulic Schematic

70-0918-000_A

013080-02_01



11 Decal Placement

For operator's safety, all decals appearing in "Decal Kit" must be in a conspicuous place on control side of liftgate to be read by operator. This is typically a combination of decals on the liftgate and truck body. Please make sure to place the maximum capacity decal (C) on driver and curb side.



IMPORTANT: Never remove, modify, or paint over any decal.

Decal Kit			
Decal	Qty.	Part No.	Description
1	1	ML85-0922-000	Operating Instructions
2	1	ATG-URGWA	Urgent Warning: Elevating gate instructions
3	2	ATG-WLH	Warning: liftgate can crush
4	2	ATG-PLAT	Warning: Always stand clear of platform area
5	1	ATG-RESET	Circuit Breaker Protection
6	1	ATG-BKR	Circuit Breaker Reset (must be located at the circuit breaker location)
7	1	ATG-OPENILD	Notice For Open And Close
8	1	ATG-CAB	Liftgate Shut-Off (located next to shut-off switch in cab)
9	1	ATG-FT	Notice for Foot Control (if applicable)
10	2	ATG-XXXX	Capacity (Liftgate capacity can be found on serial number plate located on the liftarm)
11	1	ML2038837	Palfinger Logo (Yellow)

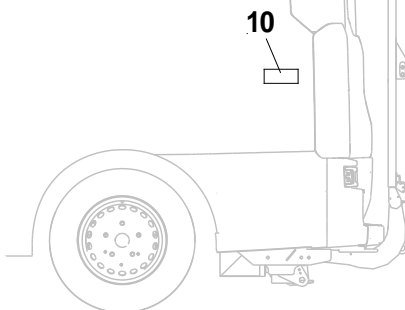
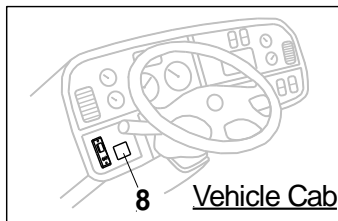
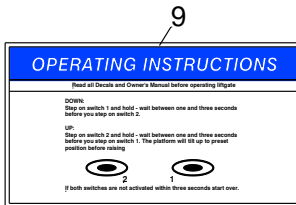
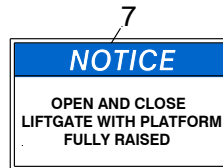
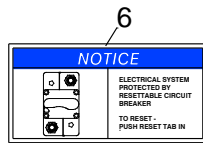
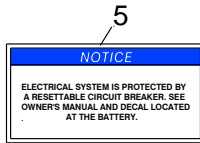
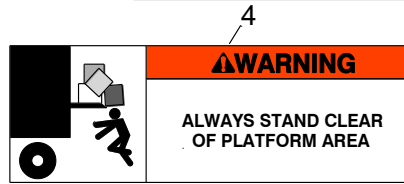
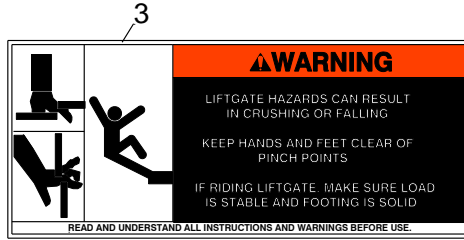
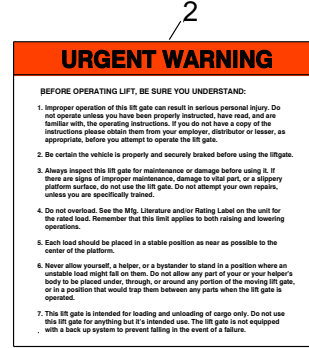
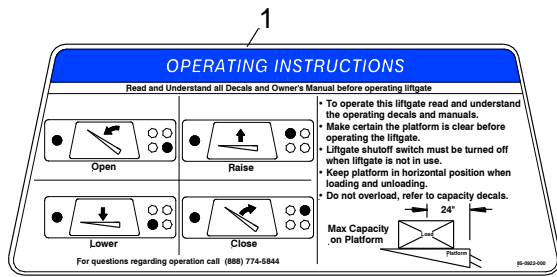

Driver Side of Vehicle

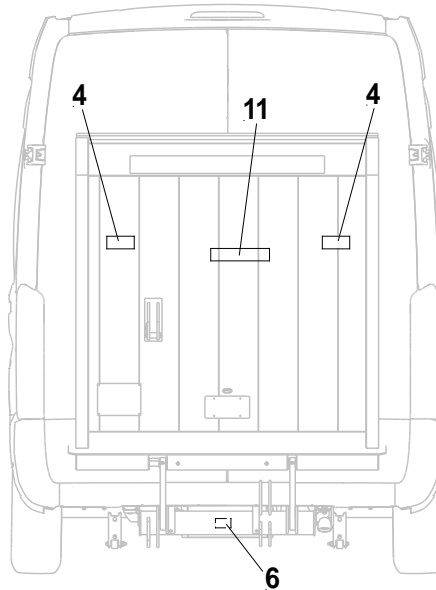

Rear of Vehicle

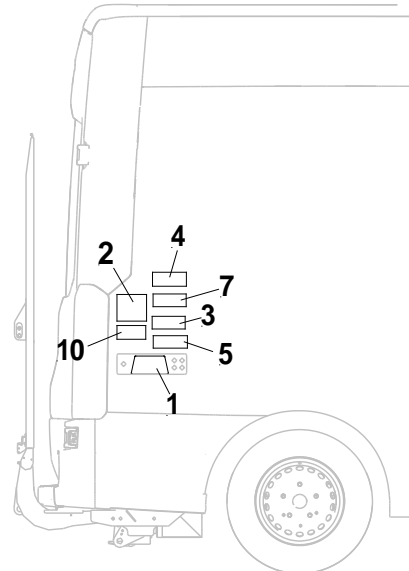

Curb Side of Vehicle

12 Required Information for Ordering Spare Parts and Repairs

12.1 Ordering Spare Parts

In order to assure quick delivery of spare parts, please always state the following information when making orders:

1. Liftgate model & serial number.
2. Designation and number of the spare part in accordance with the spare parts list.
3. Designation and number marked on the individual component (if available).

12.2 Repairs

Parts sent to Palifinger Liftgates to repair must be accompanied by a letter (in separate cover) giving details and scope of the repairs required.

13 Warranty

PALFINGER Liftgates provides warranty as part of its conditions of delivery.

Spare part deliveries are all billed. Palifinger Liftgates then issues credit for all or part of the invoiced sum, when Palifinger Liftgates has been able to determine that the warranty claim is justified as defined by its warranty conditions. Palifinger Liftgates does this by inspecting the defected parts which are sent back to Palifinger Liftgates freight-prepaid as well as the written description of the problem which must have been filled out in full.

The parts that are sent back to Palifinger Liftgates, marked with serial number and address, become Palifinger Liftgates' property if the warranty claim is accepted.

All warranty claims must be received **within 30 days** of repair or replacement. Including the following information:

1. Liftgate model.
2. Liftgate serial number.
3. Description of problem.
4. Itemized bill of repair with breakdown of number of hours to perform warranty work and labor charges per repair.
5. Parts used for repair with Palifinger Liftgates part number.
6. RMA#.
7. Contact at Palifinger Liftgates, if applicable.

Model	Pump and Motor	Cylinders	Hardware	Control System	Hydraulic
Minifix	2 yr	3 yr	3 yr	2 yr	2 yr

Table Warranty Coverage Schedule

Effective: Aug. 2010

14 Contact Address

15939 Piuma Ave
Cerritos, CA 90703
Phone: (562)-924-8218
Fax: (562)-924-8318

E-mail (parts order):
liftgateparts@palfinger.com

E-mail (technical support):
technicalapplications@palfinger.com



572 Whitehead Road
Trenton, NJ 08619
Phone: (609)-587-4200
Fax: (609)-587-4201

E-mail (parts order):
liftgateparts@palfinger.com

E-mail (technical support):
technicalapplications@palfinger.com