

INTERLIFT



BY PALFINGER

INSTALLATION MANUAL & CHECK OFF SHEET

ILU 40, 4000 lbs. Capacity

ILU 50, 5000 lbs. Capacity

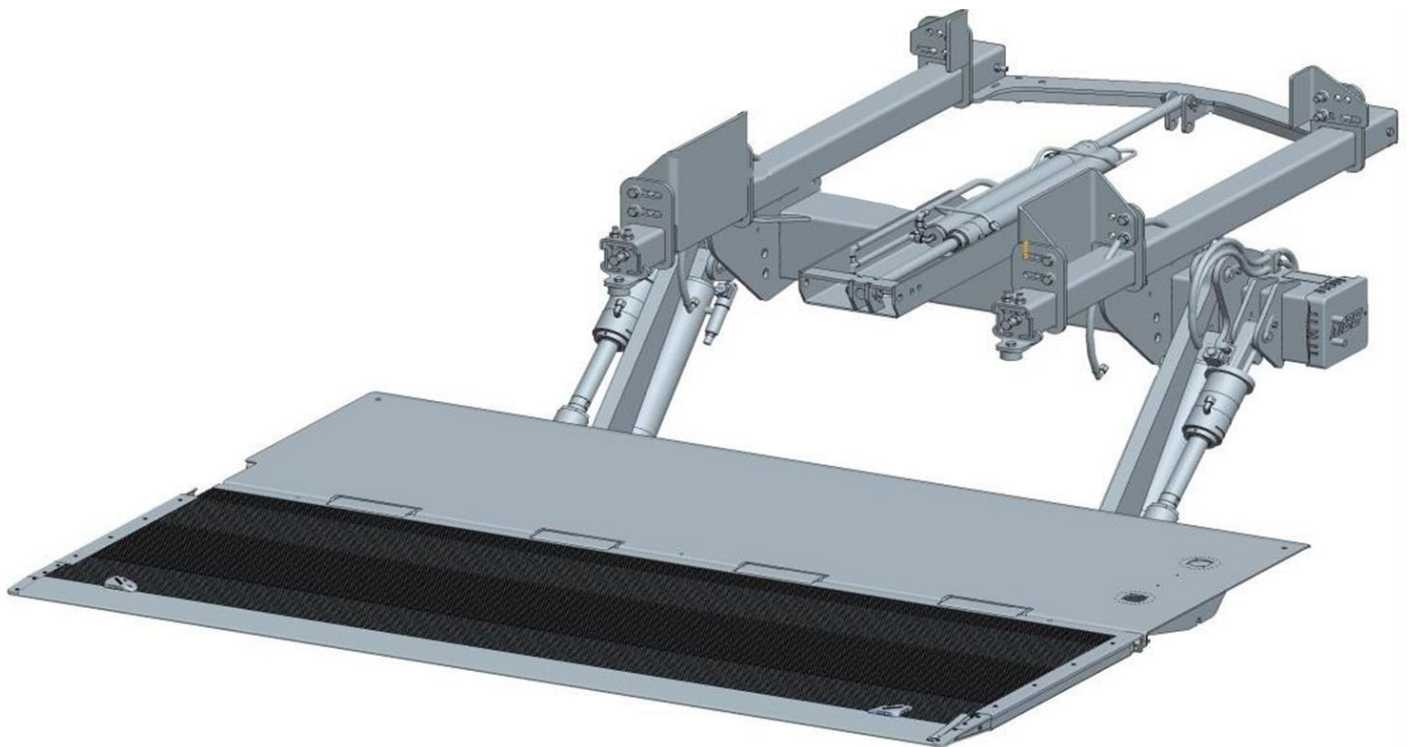

ILU 40/50 Installation Manual
Document Part Number: 90-1313-200
ECN-M1723, Rev. 1.7, 01-22-24
Copyright © 2023 Palfinger Interlift, LLC.
All rights reserved.

Information in this document is subject to change without notice.
Visit www.palfinger.com for up to date information and notifications.

If you received this product with damaged or missing parts,
contact INTERLIFT Liftgates at (888)-774-5844

Parts Order/Inquiries
liftgateparts@palfinger.com

Technical Support
technicalapplications@palfinger.com



15939 Piuma Ave.
Cerritos, CA 90703
Tel (888) 774-5844
Fax (562) 924-8318



572 Whitehead Road.
Trenton, NJ 08619
Tel (609) 587-4200
Fax (609) 587-4201

TABLE OF CONTENTS

Manual Updates..... 5

1 Safety Information 6

2 Important Notes:..... 7

3 Chassis Dimension Sheets 9

4 Installation Dimensions 11

 4.1 General Bed Height Ranges for ILU liftgates..... 12

 4.2 Chassis and Body Preparation..... 13

 4.2.1 Mount frame clearance..... 13

 4.2.2 Rear sill preparation 15

5 Gate Installation..... 17

 5.1 Slide rail bracket installation (Truck)..... 17

 5.2 Liftgate attachment (Truck) 18

 5.3 Liftgate Installation (Trailer)..... 20

 5.4 Control power wiring setup..... 21

 5.5 Platform installation..... 22

 5.5.1.1 Swing-door platform modifications 22

 5.6 Lift arm Up-stop installation and rail stops setup 23

 5.7 Control box installation..... 24

6 Gate adjusting and detailing 25

 6.1 Setting B-13 lift arm sensor 25

 6.2 Setting B-15 Platform sensor 26

 6.3 Platform adjusting with bolts 27

7 Electrical Installation..... 28

 7.1 Breaker Installation 28

 7.2 Wiring schematic main battery power - Truck..... 29

 7.3 Wiring schematic main battery power - Trailer setup..... 30

 7.4 On/Off Switch Installation..... 31

 7.4.1 Truck Setup..... 31

 7.4.2 Trailer Setup..... 31

 7.5 Control Board Wiring and Connector Setup 32

 7.6 Control Board Plug Setup and System Codes..... 33

 7.7 Control box wiring (internal) 34

 7.8 2 Button Remote Hand Control 34

8 Hydraulic schematic..... 35

8.1	Lubrication	36
9	Decal Placement	37
10	Final Inspection Check List	39

Company Information:

Company Name: _____

Advisor Name: _____

Vehicle Year Make & Model: _____

Liftgate Information:

Liftgate Serial Number: _____

Liftgate Model Number: _____

Date of Purchase: _____

Date of Installation: _____

Manual Updates

Revision	Description
v1.7	<ul style="list-style-type: none"> • Changed the logos, from Palfinger to Interlift

Recommended Tools For Installation

Metric Wrench Set	Basic Screwdrivers	Pliers	Wire Crimp Pliers
Test Light	Snap Ring Pliers	Hammer	Metric Allen Set 1.5mm-10mm
½" Impact & Sockets	Sm. Metric Socket Set	Assorted Drill Bits	Floor Jack or Equiv.
Sm. To Med. Bottle Jack	Forklift or O/H Crane	Hand Held Grinder	Paint Gun
Pry Bar	3/8 Drill Motor	Grease Gun	Heat Gun or Equiv.
Min. 250 Amp Welder	Cutting Torch or Equiv.		

1 Safety Information

This manual follows the Guidelines set forth in “[ANSI Z535.4-2007](#)” for alerting you to possible hazards and their potential severity.

DANGER

! **DANGER** indicates an imminently hazardous situation which, if not avoided, **will result** in death or serious injury.

WARNING

! **WARNING** indicates potentially hazardous situation which, if not avoided, **could result** in death or serious injury.

CAUTION

! **CAUTION** indicates a potentially hazardous situation which, if not avoided, **may result** in minor or moderate injury.

CAUTION



CAUTION without the safety alert symbol is used to address practices not related to personal injury.

(In this manual we use it to alert you to potentially hazardous situation which, if not avoided, may result in property damage.)

NOTICE

NOTICE without the safety alert symbol is used to address practices not related to personal injury. *(In this manual we use it to alert you to special instructions, steps, or procedures.)*

2 Important Notes:

1. **Read Manual completely before beginning any work**
2. Refer to your truck manufacturer instructions before adding any auxiliary equipment.
3. Pay Special attention to items marked with this symbol: 
4. All welding should be performed by qualified personnel per AWS standards
5. Always Ground closest to your welding point to prevent arcing through moving parts
6. Contact INTERLIFT Liftgates for Special Installations not covered in this Installation Manual
7.  Do not paint cylinder shafts or nylon rollers (Use non-chlorinated brake cleaner to remove over spray)
8. Verify that pin lock bolts are tight
9. Grease all pivot points
10. Verify that ALL decals are placed properly (Contact INTERLIFT Liftgates to replace any missing decals)
11.  Final Check-Off-Sheet at rear of this manual **MUST** be filled out and kept in your records for future reference.
12. Refer to owner's manual for troubleshooting & repairs.

Important Dimensions: (Refer to line drawing on following pages)

- 1) **BED HEIGHT** Bed Height Ranges: Max=Unloaded / Min=Loaded Truck
 - Measure from top of body floor to ground. Vehicle must be on flat level ground
- 2) **MOUNT FRAME CLEARANCE**
 - Measure from **BACK** of truck/trailer to spring/tire or air suspension components that can interfere with the liftgate installation
- 3) **REAR SILL HEIGHT and DESIGN**
 - Measure top of floor to bottom of buck plate and verify design regarding to Figure 1.

Mounting Notes:

Read and clearly understand manual BEFORE beginning ANY work



The basic rule for installing an ILU INTERLIFT Liftgate is to **MOUNT THE FRAME AS HIGH AS POSSIBLE** to achieve **MAXIMUM GROUND CLEARANCE** and **MINIMIZE THE “F” DIMENSION.**



- Minimum bed height dimensions are **ALWAYS MAXIMUM LOADED TRUCK**
- Floor Height Ranges: Max=Unloaded Truck; Min=Loaded

Installing a gate at or close to minimum bed height normally results in a gate that **will NOT open and close** from stored position **if the minimum floor height is exceeded when truck is loaded.**

Call tech support before starting the installation if you have any questions or concerns on mounting dimensions → 888-774-5844

3 Chassis Dimension Sheets



Trailer Chassis Dimension Sheet

Customer Information

Quote#/SO#: _____
 Company: _____
 Phone: _____
 Email: _____ @ _____

Liftgates Information:
 Model: _____
 Capacity: _____
 Platform Size: _____
 Platform Material: _____

Trailer Information

Trailer Specifications:		Type of Body (check applicable) <input checked="" type="checkbox"/>	Type of Rear Door (check applicable) <input checked="" type="checkbox"/>
Manufacturer: (ex. Utility)		Van	Flip-Up
GVWR: (ex. 68,000 lbs)		Flatbed	Roll-Up
Length: (ex. 53ft)		Reefer	Swing
Width: (96", 102")		Other (specify) _____	Other (specify) _____

Trailer Dimensions

- A = Bedheight: Top of trailer floor to level ground (with airbags up):.....
 B = Top of floor to bottom of trailer cross member:.....
 C = Rear sill height (Top of floor to bottom of buck plate): *If Stepped sill complete M,N; If Tapered sill complete O, P*
- Flush

C = _____

Stepped

M = _____
N = _____

Tapered

O = _____
P = _____
- D = Crossmember height:.....
 E = Tire to end of vehicle body:.....
 F = Bogie to end of vehicle body:..... Sliding Suspension? Yes _____ No _____
 If Yes complete G, H, I, K, and L dimensions
- G = Inside horizontal width of sliding suspension angles:.....
 H = Diameter of sliding suspension holes:.....
 I = Hole spacing:.....
 J = Bottom of crossmembers to bottom of sliding ramp box, if applicable:.....
 K = Rear sill face to first slider hole:.....
 L = Top of floor, where liftgate platform will meet floor, to the center of the trailer slider holes:.....
 X = Eyebrow depth:.....
 Z = Top of floor, where the liftgate platform will meet the top of the eyebrow:.....

Notes:

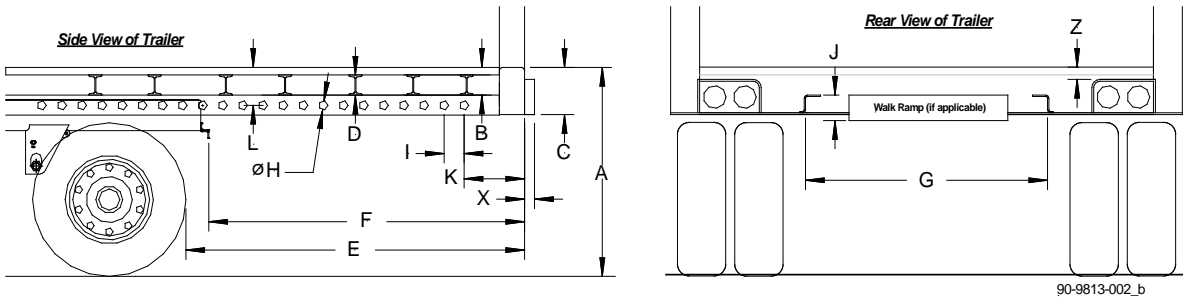

90-9813-002_b

Figure 1 Trailer dimension sheet



Truck Chassis Dimension Sheet

Customer Information

Quote#/SO#: _____
 Company: _____
 Phone: _____
 Email: _____ @ _____

Liftgates Information:
Model
Capacity
Platform Size
Platform Material

Truck Information

Truck Specifications:	
Manufacturer: (ex. Hino)	
GVWR: (ex. 68,000 lbs)	
Length: (ex. 53ft)	
Width: (96", 102")	

Type of Body (check applicable) ✓	
Van	
Flatbed	
Reefer	
Other (specify) _____	

Type of Rear Door (check applicable) ✓	
Flip-Up	
Roll-Up	
Swing	
Other (specify) _____	

Truck Dimensions

- A = Bedheight:..... _____ Loaded Bedheight:..... _____
- B = Top of floor to bottom of frame:..... _____
- C = Rear sill height:..... _____
- D = Spring hanger to end of body (if applicable):..... _____
- E = Air bag suspension to end of body (if applicable):..... _____
- F = Tire to end of vehicle body:..... _____
- G = Gas tank to end of body (if applicable):..... _____
- H = Fuel filler hole to end of body (if applicable):..... _____
- I = Bottom of frame to bottom of gas tank (if applicable):..... _____
- J = Top of floor to bottom of sliding walk ramp (if applicable):..... _____
- K = Frame Width: Width of chassis frame:..... _____
- L = Frame Height: Height of chassis frame:..... _____

Notes:

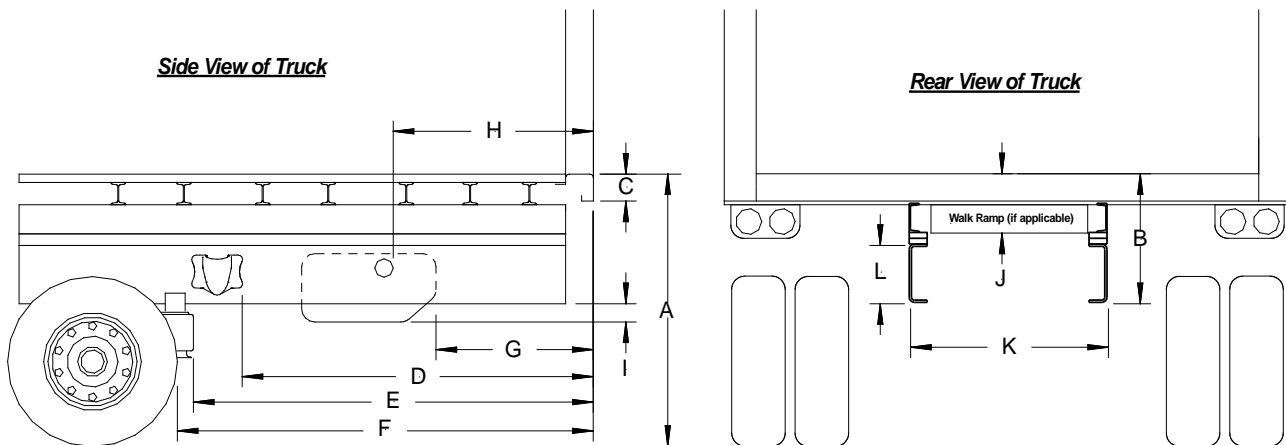

90-9813-003_b

Figure 2 Truck dimension sheet

4 Installation Dimensions

Installation Dimension sheets are supplied with each individual ILU, as there are too many different setup combinations for a generic installation drawing. When the liftgate is ordered, INTERLIFT Liftgates supplies a drawing based upon the Chassis dimension sheet (Figure 1 and Figure 2) supplied by your company.

IMPORTANT:

Before starting the installation, make sure that you have your own reference sheet that was supplied to INTERLIFT Liftgates together with the installation lay-out drawing. Compare it with the truck you are about to start the installation on. If the **units are different** than the supplied lay-out, contact your supervisor and INTERLIFT Liftgates to go over the differences.

NOTICE

Do not start installation if your truck/trailer does not match up with INTERLIFT Liftgates supplied drawing!

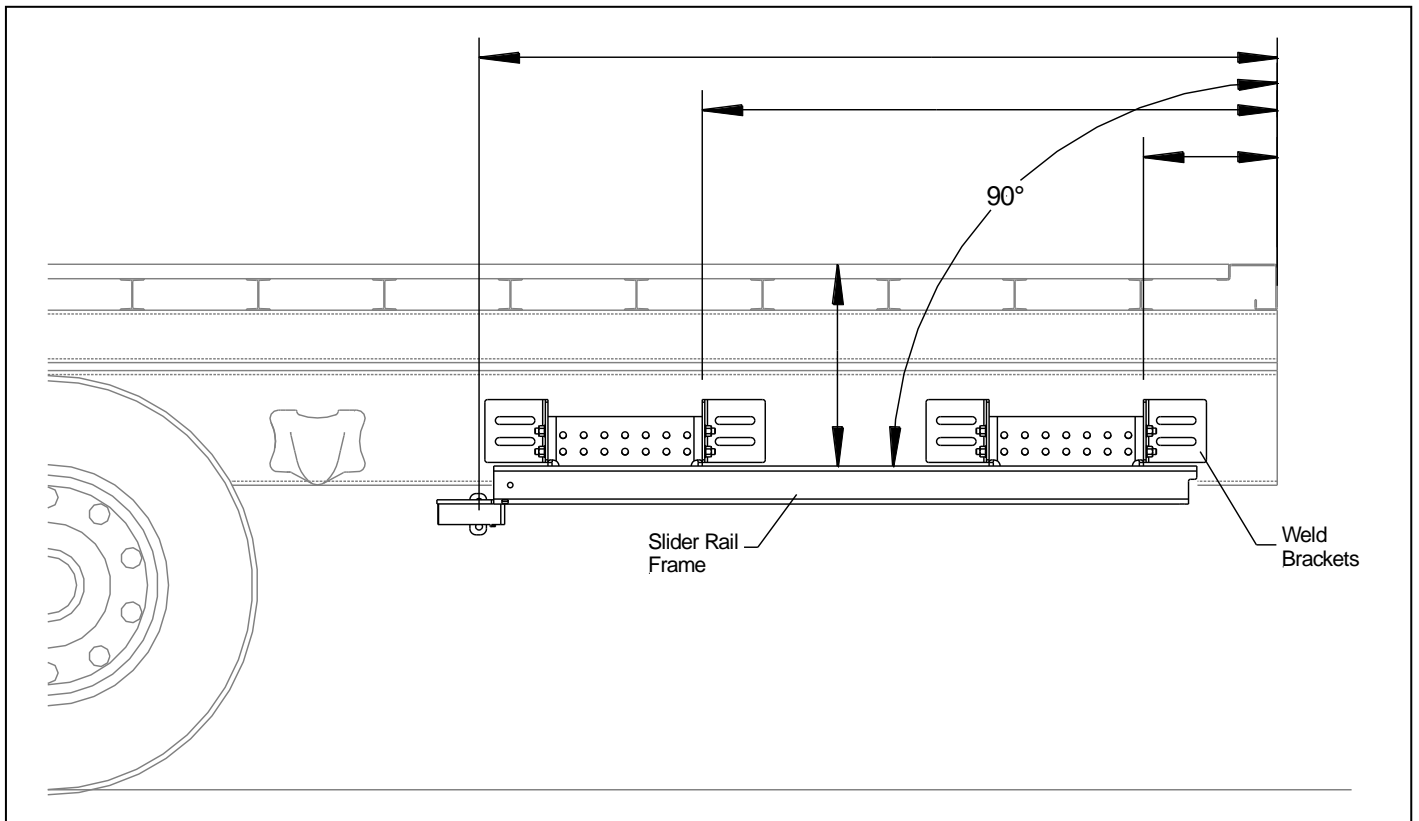

Figure 3 Installation Drawing - Provided by INTERLIFT Liftgates Engineering Department

4.1 General Bed Height Ranges for ILU liftgates.



Minimum bed height is when truck/trailer is loaded to MAX GVW (all dimensions in inches)

NOTICE

ILU 40-50 800mm arm

36" - 56"

4.2 Chassis and Body Preparation

4.2.1 Mount frame clearance

NOTICE

- Determine the correct mounting clearance according to your specific lift and chassis.
- With long overhangs it is even more important to maintain Max ground clearance.
 - o GROUND CLEARANCE = BOTTOM OF LIFTGATE FRAME TO GROUND
- Determine if you need to move chassis U-bolts or if you have any other interferences, then proceed with installing the liftgate slide rails to the frame

IMPORTANT (Truck Installation):

- Before start of installation make sure body long rails are connected to truck frame welded with flat bars and secured against forward movement of the body.
 - o If body and frame are not connected the liftgate might push body forward.

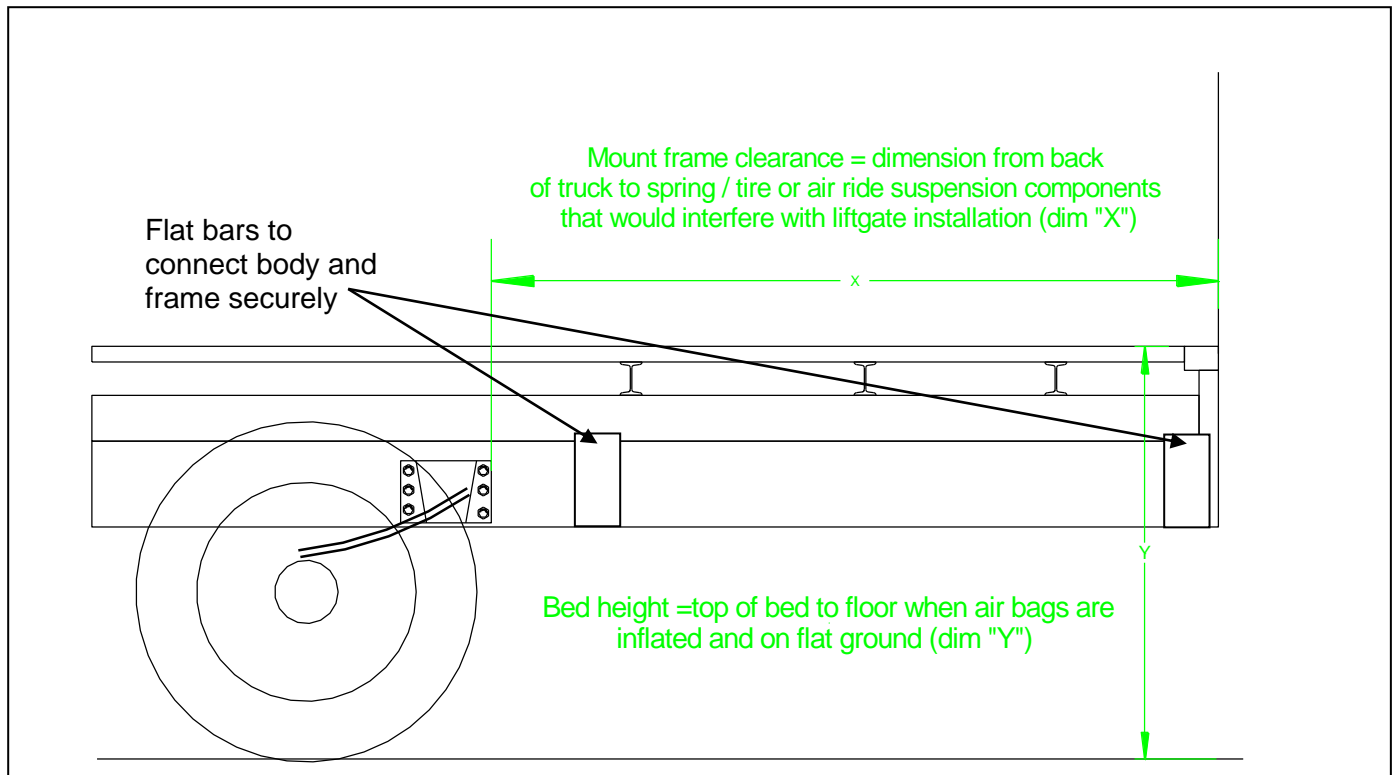
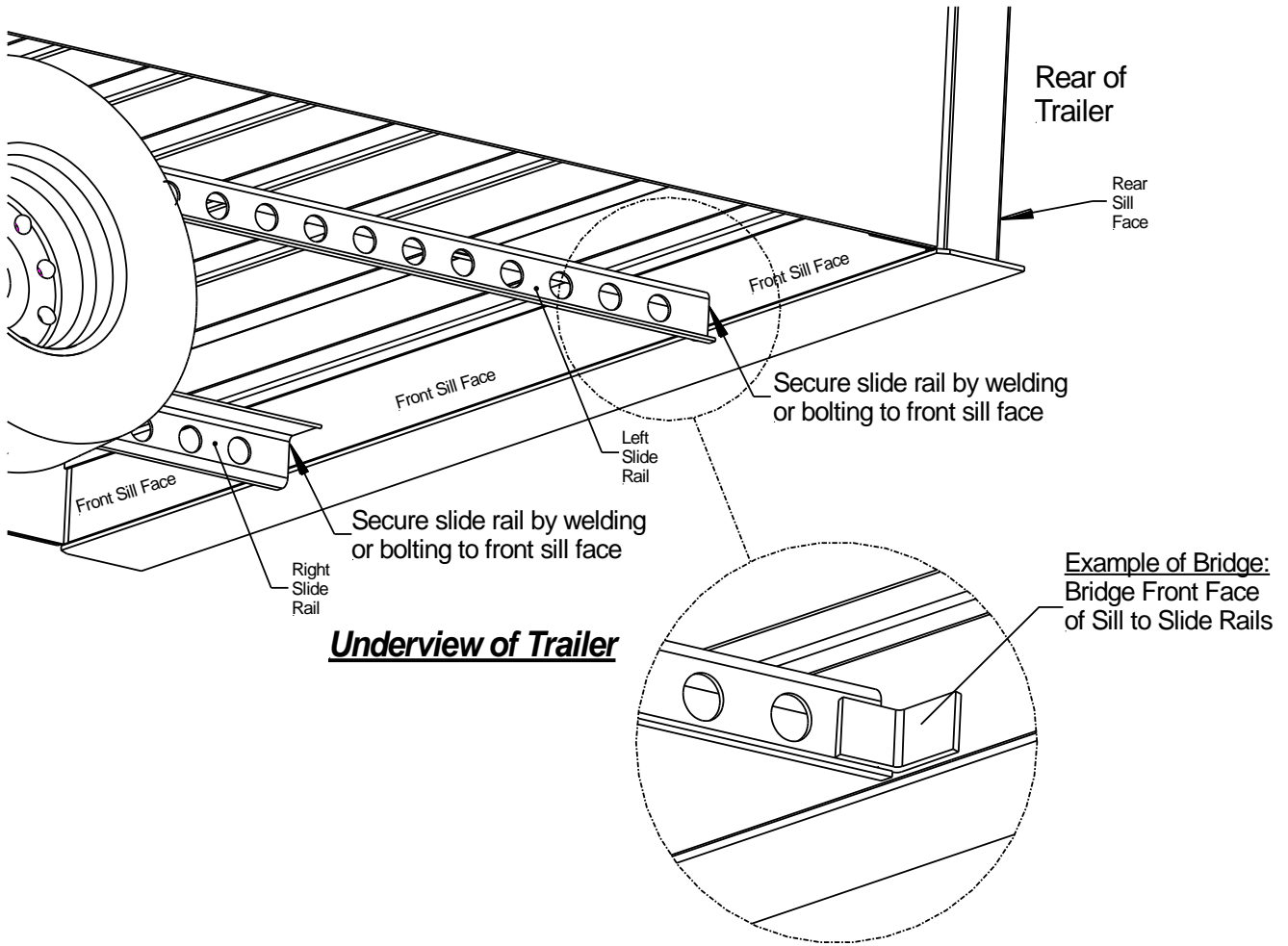

Figure 4 Mounting Clearance

IMPORTANT (Trailer Installation):

The ILU Underslider Liftgates are mounted to the trailer slide rails. During liftgate operation, there are lot of forces on the trailer slide rails, especially in the rear lift position of the liftgate. It is important to secure the rails at the rear of trailer to prevent them from starting to separate in this area. When the rails do not reach the rear and a gap remains, the gap must be bridged to connect the rails to the sill.



4.2.2 Rear sill preparation

To ensure that the gate reaches the body floor, you may need to cut out the rear sill of your truck/trailer.

NOTICE

- If sill is **less than 4"** high → No sill cut out needed
- If no cut out height is determined in drawing, cut out for best fit. **Keep at least a minimum of 4"** of sill.

CAUTION

- Reinforce every cut out of the sill to regain sill strength, required by truck/trailer OEM.

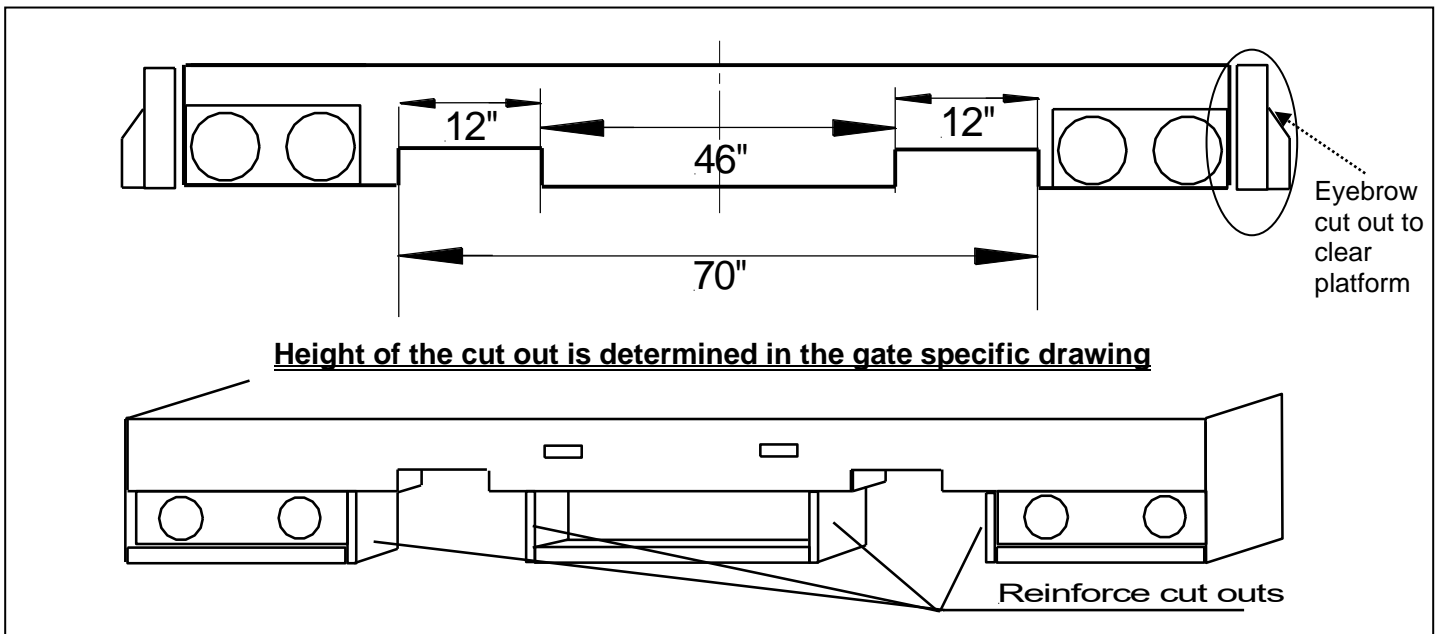

Figure 5 Sill cut-out dimensions - rear view

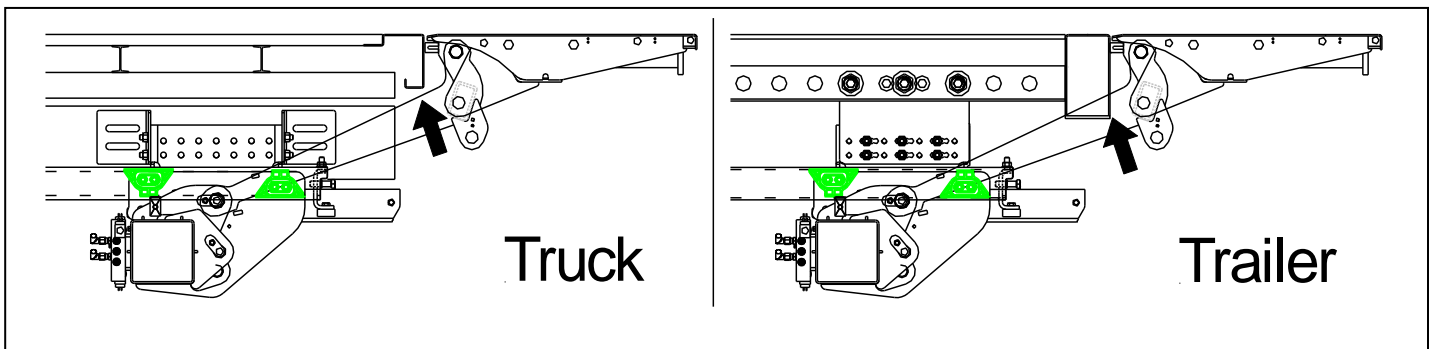

Figure 6 Sill cut-out - side view

NOTICE

- On trailers, you have to check the eyebrow clearance, and in case of interference cut eyebrow down until platform clears.
- The eyebrow cut out can be done when gate and platform are installed and you raise up gate for the first time. That gives the opportunity to keep as much of the eyebrow as possible to keep rear frame strength.

IMPORTANT!!!

- A proper preparation of the truck/trailer sets the basics for a safe, clear and fast installation process and ensures proper function of the lift gate without damage to truck/trailer or lift gate.

5 Gate Installation



WARNING

Never work under mount frame or platform without safety supports

5.1 Slide rail bracket installation (Truck)

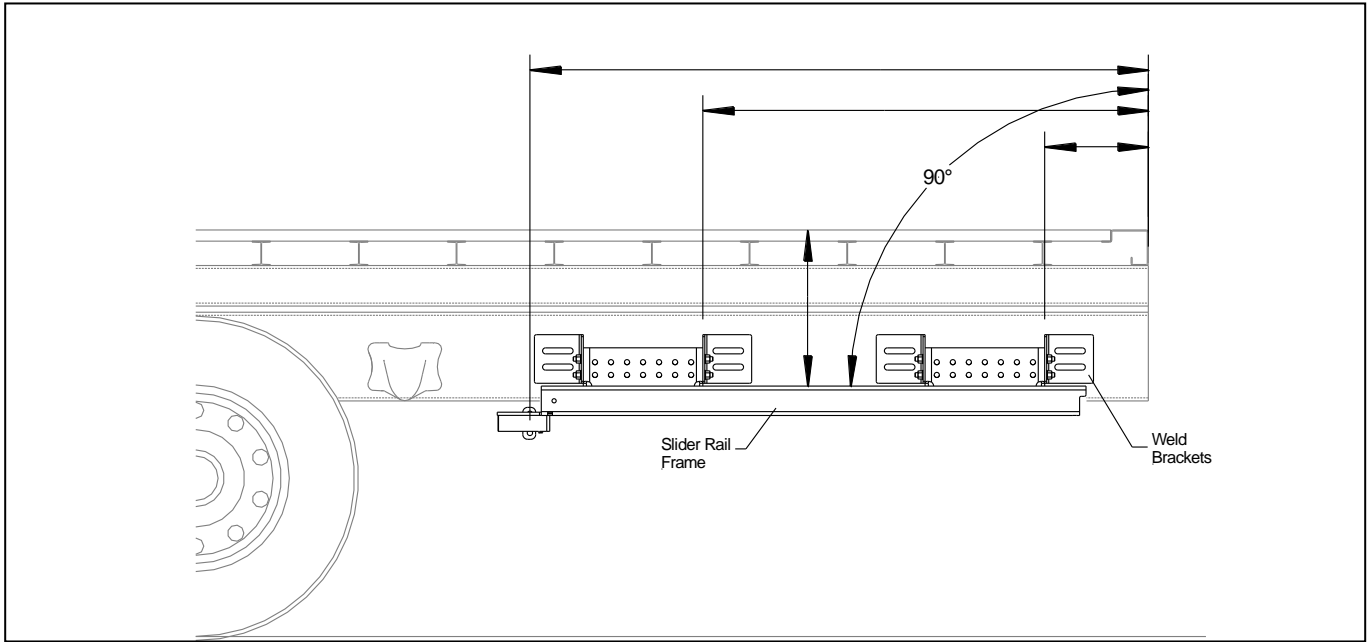
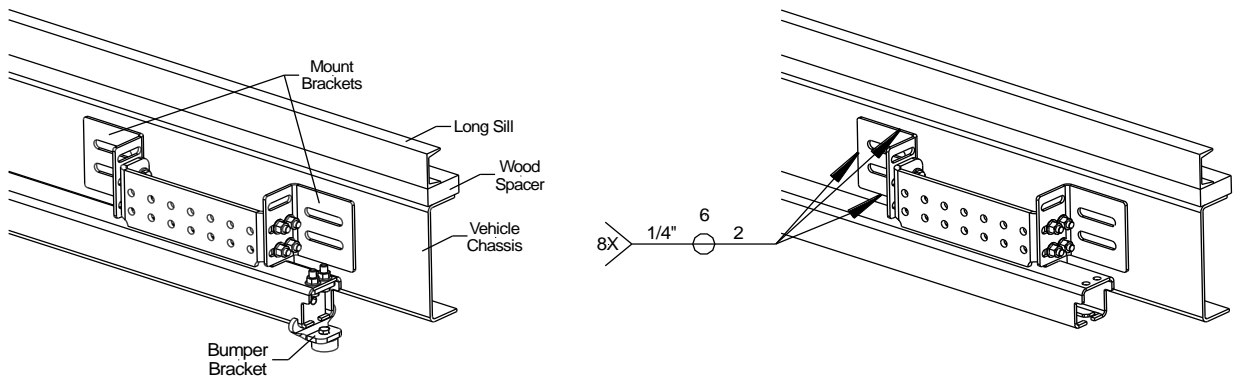

Figure 7 Slide rail installation

- 1) Make sure the specific install drawing sent with the liftgate matches the truck and gate you are about to install.
- 2) Install the slider rail frame according to drawing sent with the gate. Spot weld the mount brackets to prevent the liftgate from moving when testing. Remove bumper bracket if necessary.



5.2 Liftgate attachment (Truck)

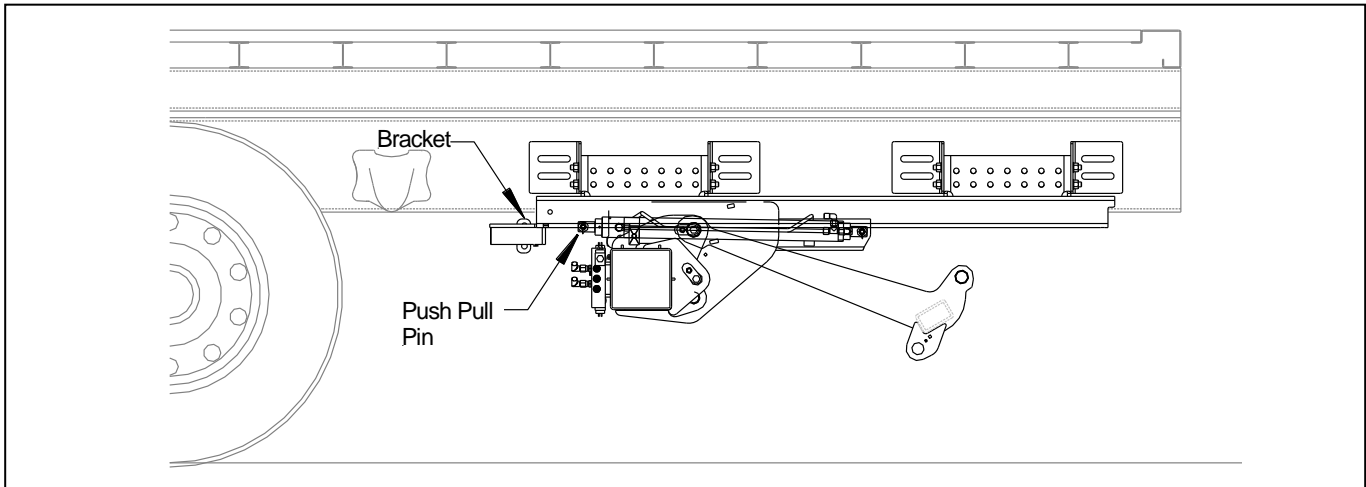

Figure 8 Liftgate installation to previous installed rails

- 3) Slide liftgate main frame assembly into previous installed slide rails.
- 4) Connect pin in front of push-pull cylinder to bracket towards truck cabin.

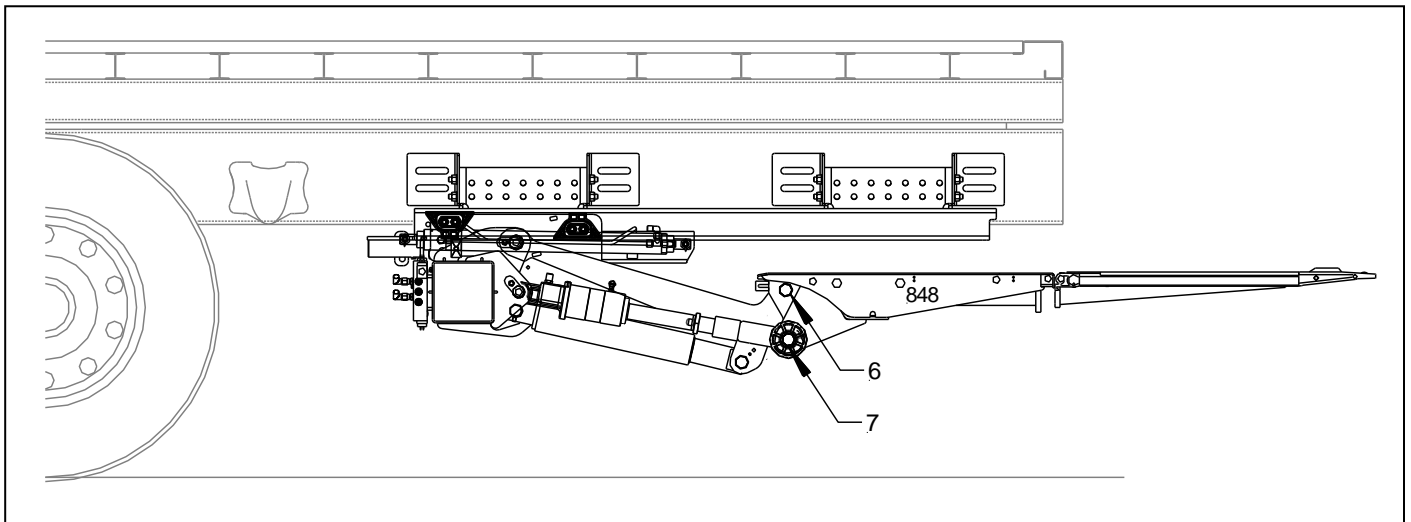

Figure 9 Platform Attachment

- 5) Connect platform to frame by using supplied pins and lock bolts.
- 6) Connect lift arm to inside clevis holes. Tighten lock nuts at pin tab to avoid pin getting loose
- 7) Connect tilt cylinder to outside holes at clevis. Tighten lock nuts at pin tab to avoid pin getting loose
 - a. To extend or retract tilt cylinders you have to connect the power supply of the gate (see chapter 5.5)
 - b. Hold B-15 sensor in a level position, the cable retainer pointing towards the front of the truck

⚠ WARNING

When gate is completely installed and tested for proper function weld a 100% around the brackets to assure a safe and secure connection of gate and truck frame

- 8) Weld mount brackets 100% to chassis after testing. Add a bridge plate above the bracket for additional support. Re-install bumper bracket.

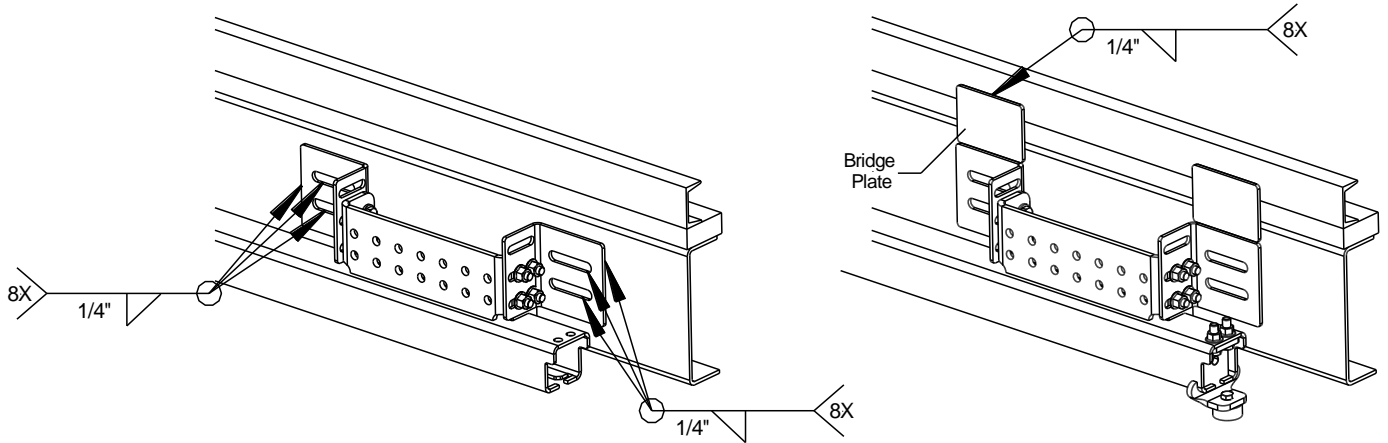

5.3 Liftgate Installation (Trailer)

NOTICE

Rapid Mount Bolt-On Plates are designed for 42.625" wide and 48.625" wide tandem slide rails.

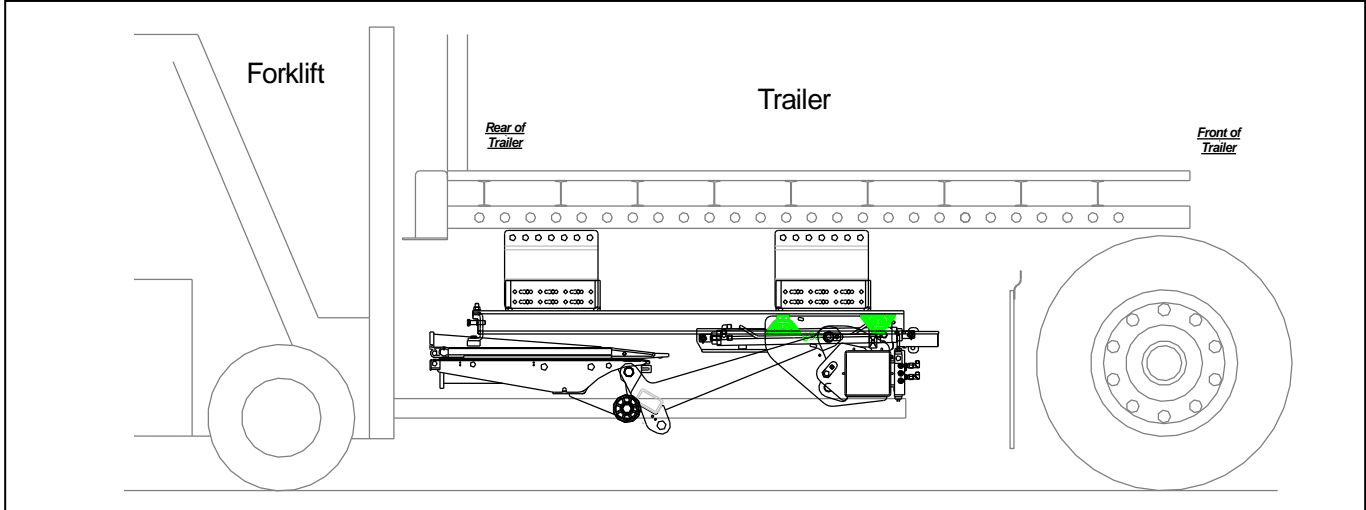

Figure 10 Liftgate Under Trailers Tandem Slide Rails

- 1) Slide liftgate main frame assembly under the trailers tandem slide rails.
- 2) Make sure the specific install drawing sent with the liftgate matches the trailer and gate you are about to install.
- 3) Raise the liftgates assembly and match the mounting holes on the tandem rails with the mounting holes on the liftgate mount plates (reference install drawing). Install hardware in the orientation shown, torque bolts to 375 ft/lbs. Use the proper configuration of the spacer based on the slide rail hole diameter.

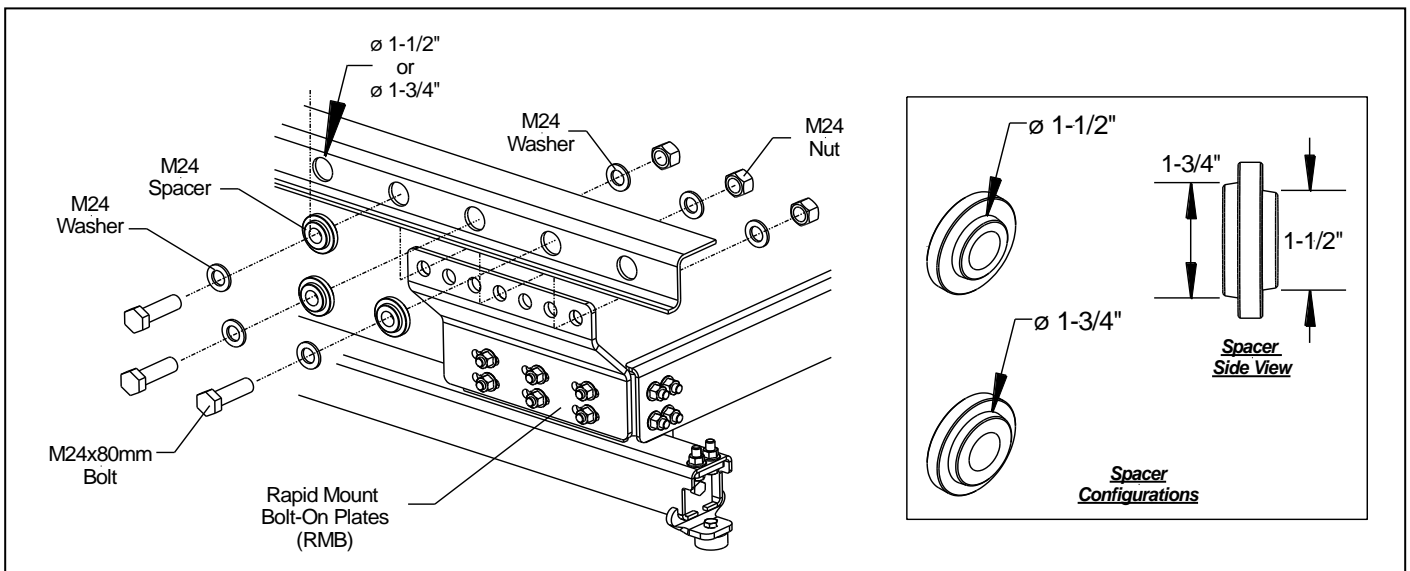

Figure 11 Rapid Mount Bolt-On Plates to Trailer Tandem Slide Rails

5.4 Control power wiring setup

To maintain the best possible power supply, install the auxiliary batteries as close as possible to the gate.

- Truck installations might not have an auxiliary battery kit (INTERLIFT Liftgates **always** recommends a kit). In this case you have to run the control power straight off the truck battery.
- Trailer installations always have a trailer battery kit (at least 2 batteries recommended)

Connect your control power to the positive (#2 & #4) and the negative (#1 & gr/ye) post of the batteries.

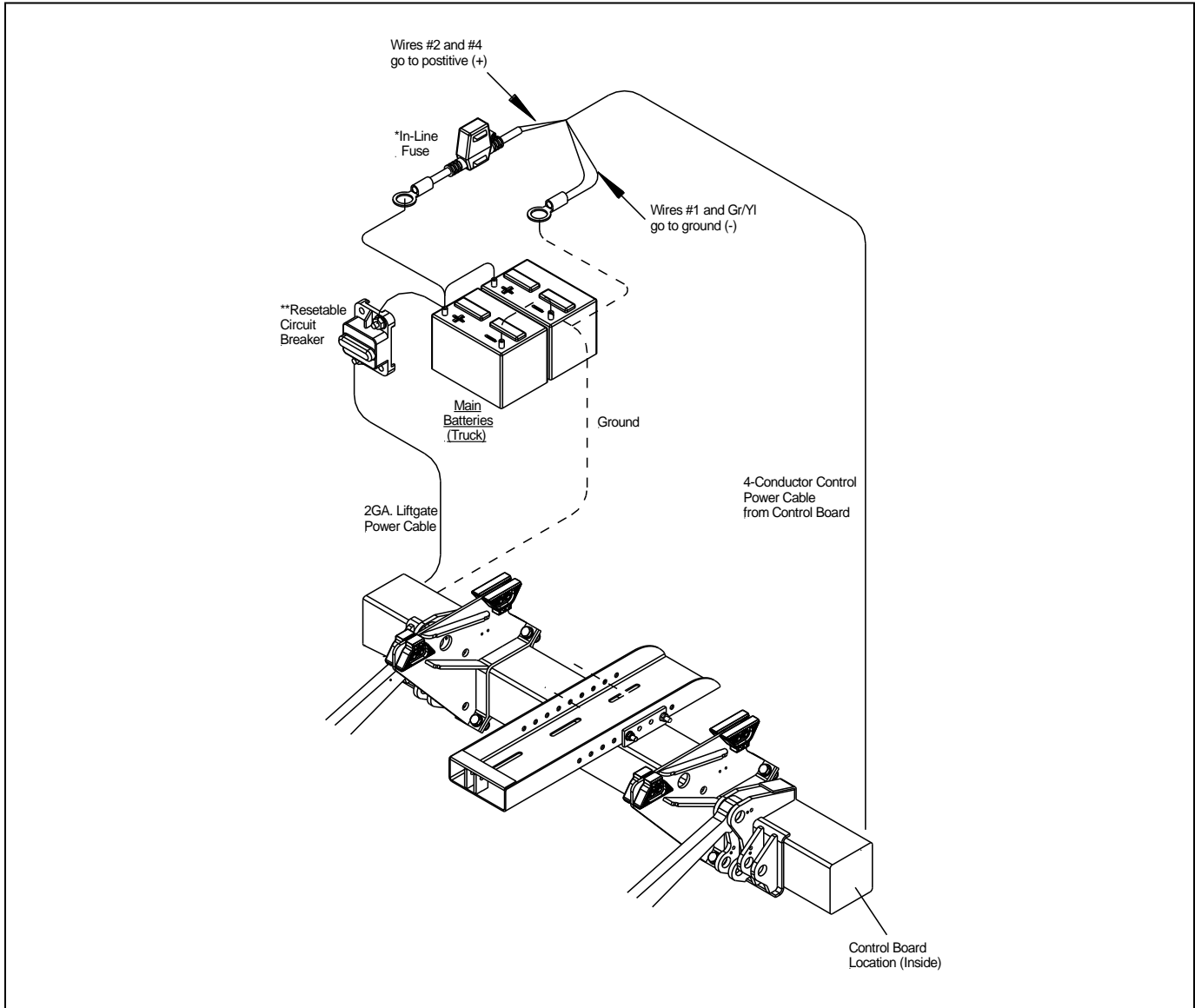

Figure 12 Board control power wiring connection and Main Power supply setup

5.5 Platform installation

To install the platform (if not preinstalled by manufacturer) follow these steps:

- 1) Unfold platform and clamp on to forklift or overhead crane.
- 2) Slide out gate to the point that you are able to attach platform clevis to lift arm and tilt cylinders.
- 3) Bring platform close to gate and attach lift arm to platform using provided pins
- 4) To attach tilt cylinders, hold B-15 platform sensor so that you are able to extend tilt cylinders when turning the tilt switch until you match pin holes on platform and tilt cylinder head
- 5) If all **4 pins** (2 each side) are in place and **secured with lock bolts** install B-15 sensor to platform and connect foot control and warning light cables.
- 6) Push all excessive cable inside platform to protect connections from environmental influences.

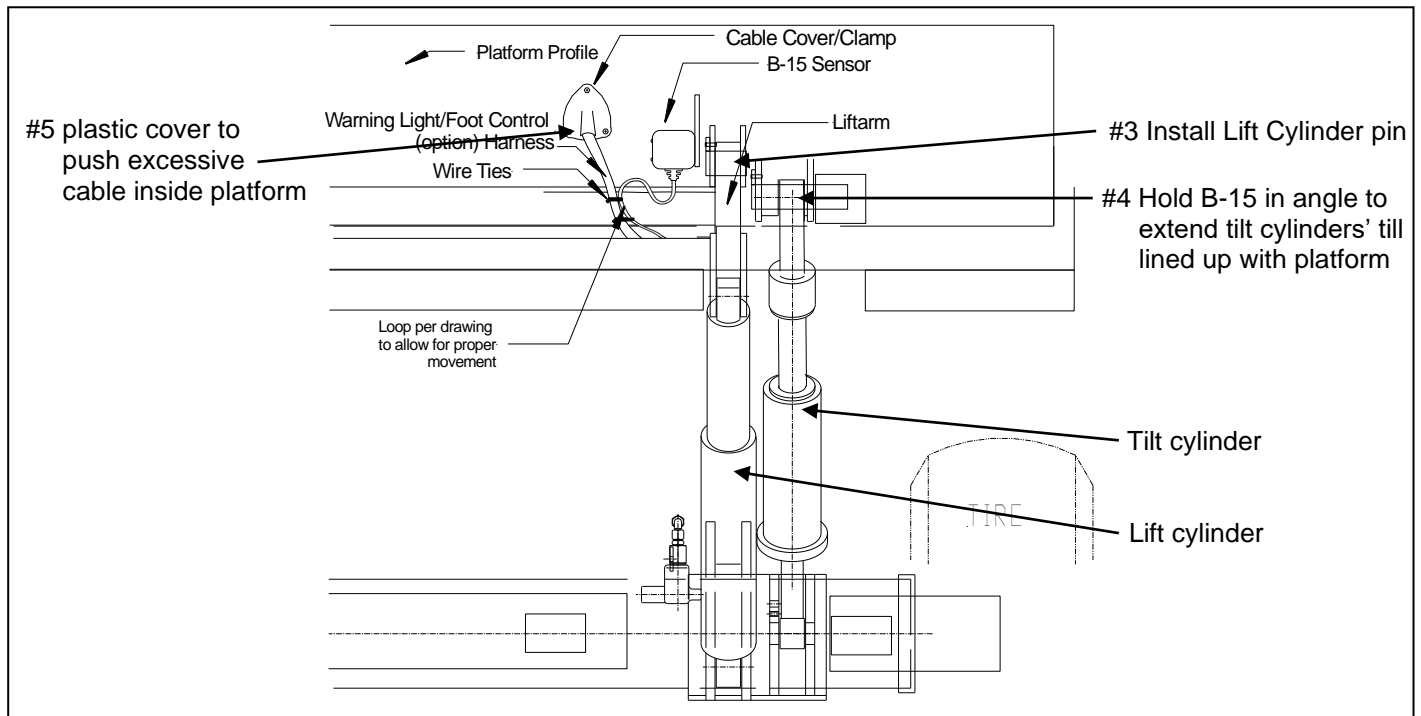

Figure 13 Platform installation and wiring

5.5.1.1 Swing-door platform modifications

On swing door applications there might be cutouts necessary to clear the lower cam locks

- If cut outs have not been made, damage to platform tip is possible.
- To avoid unnecessary gaps between trailer and platform, keep cut out as small as possible

5.6 Lift arm Up-stop installation and rail stops setup

With gate power set up and fully functional, place gate and platform in final operational position for installation of up and slide out stops. Start with up stops and verify flush fit, then continue with slide stops.

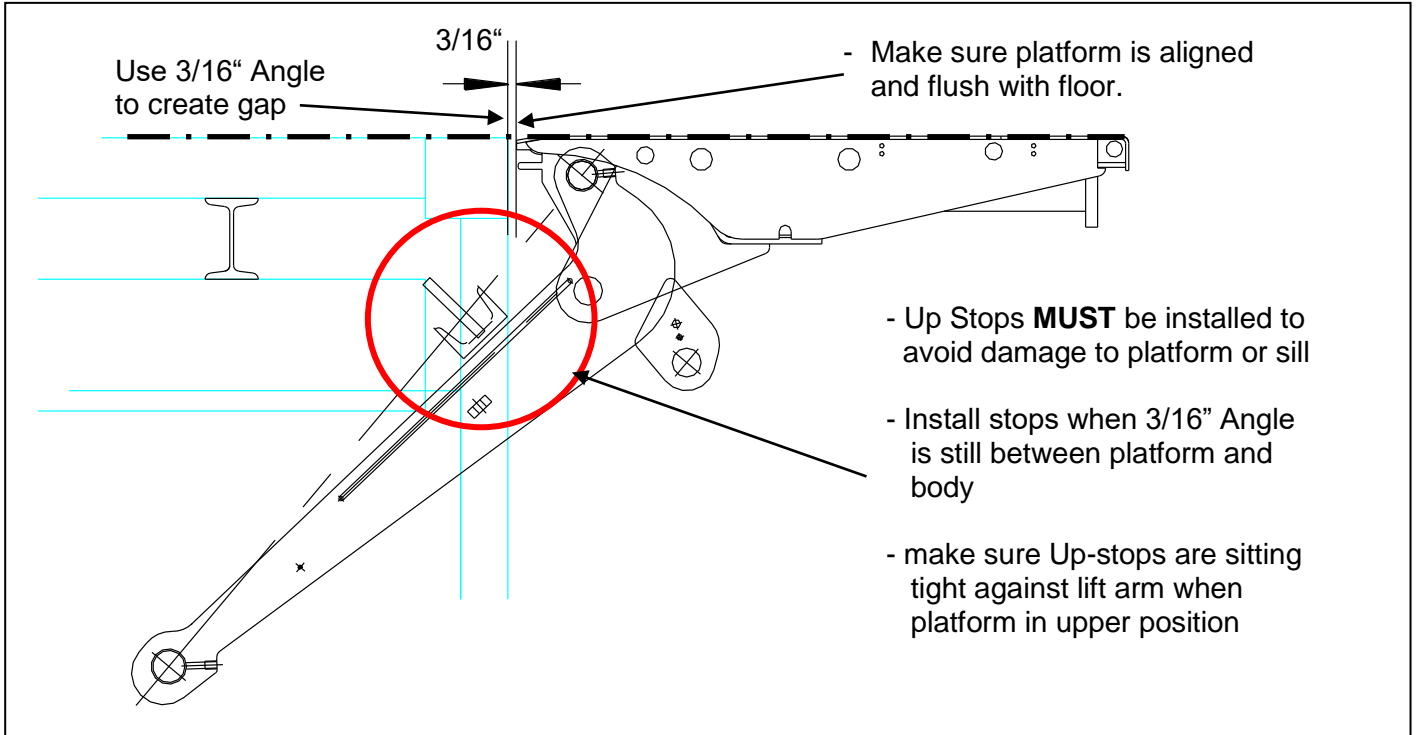
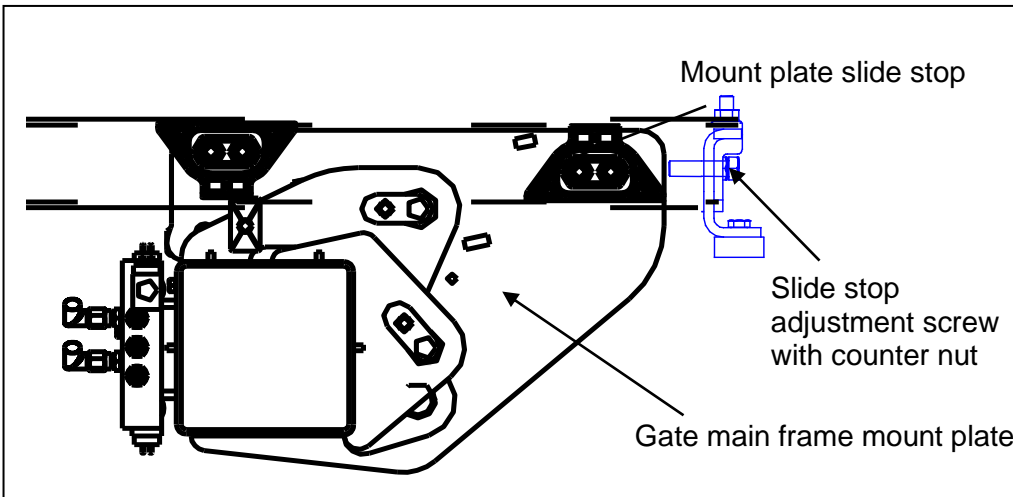

Figure 14 Installation of up-stops

NOTICE

Ensure that platform main section is not set under pressure against truck/trailer body when install up stops



When platform is in correct position (see Figure) and up stops are in place, set slide stops tight against Mount plates and fasten bolts tight with counter nut.

Figure 15 Mount plate slide stops

With Up-stops and slide stops in place, run gate through several cycles and check perfect match of gate and body floor. Make sure slide stops are tight and alignment of platform and body is ok.

5.7 Control box installation

Install the control box on the passenger side by welding or bolting the z-brackets to the cross members of the truck or trailer. Run the cable along the slide rail and tie it down so it cannot interfere with the mount plates when gate is sliding in or out. Note: Control box should not protrude outside the vehicles body width once installed.

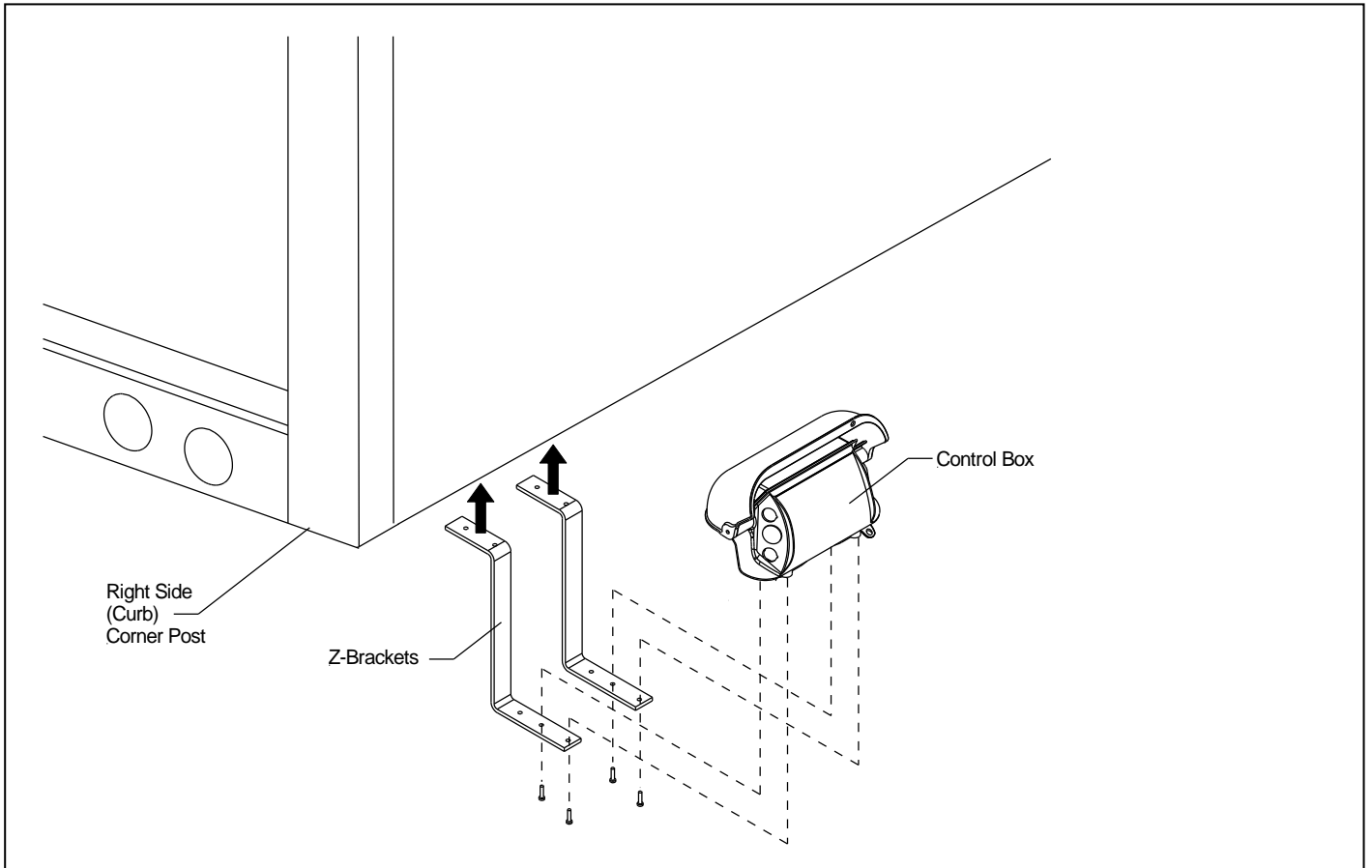

Figure 16 Control box placement

6 Gate adjusting and detailing

6.1 Setting B-13 lift arm sensor

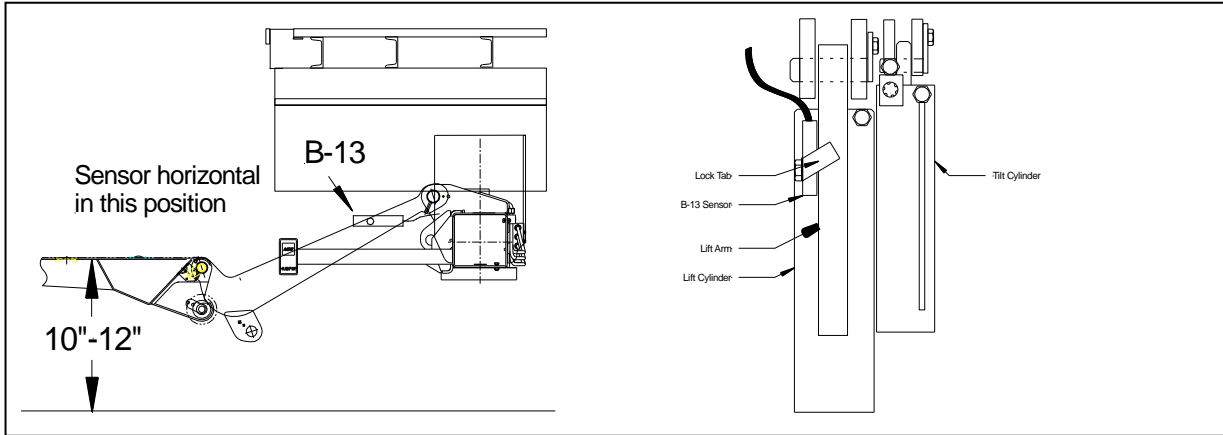

Figure 17 B-13 lift arm adjustment

- To set the sensor correctly, lift unfolded platform up about 10" to 12" above ground.
- Adjust the B-13 sensor in a way that it is level with the ground like shown in Figure 17.
- Raise gate all the way up after adjusting and lower to the ground. Platform tip will tilt towards ground if operator stays on the lower switch for about "3" seconds after nylon rollers touching ground.
- Cycle platform several times to check operation after tightening.
- Fold down Lock Tab tightly onto Lift Arm (see Figure 18).

NOTICE

- At **NO** time the platform tip should tilt towards ground **while lowering**.
- Platform should **only tilt** after Nylon rollers contact ground and operator is on the down switch.
- After sensor is properly set, tighten lock bolt to 43 in.lbs/3.5 ft.lbs.
- Never over torque B-13 lock bolt. Sensor will break and malfunction.
- Verify colored side of sensor is out (facing away from arm).
- Under torqueing B-13 lock bolt may allow sensor to shift during normal gate operation.

6.2 Setting B-15 Platform sensor

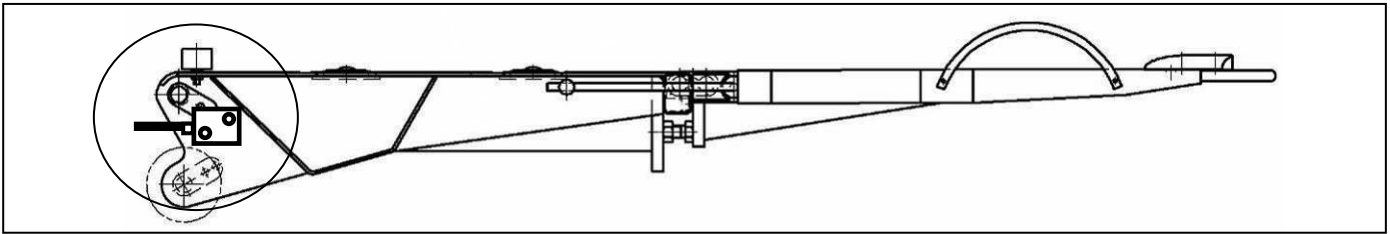

Figure 18 B-15 adjustment on platform

- Mount the platform sensor B-15 to the right-hand side of the platform as shown in Figure 18. Make sure to loop wire around to give it enough slack in normal operation and route clear of any pinch points.
- Verify B-15 is set correct, when cable restrainer is parallel with platform surface.
- **B-15 is working correct if platform finds preset level position while tilting up form ground position**
- If platform is only lifting, without leveling out - battery power supply is low, check and charge battery. (On trucks – start truck and run in high idle for 5 – 10 Min)

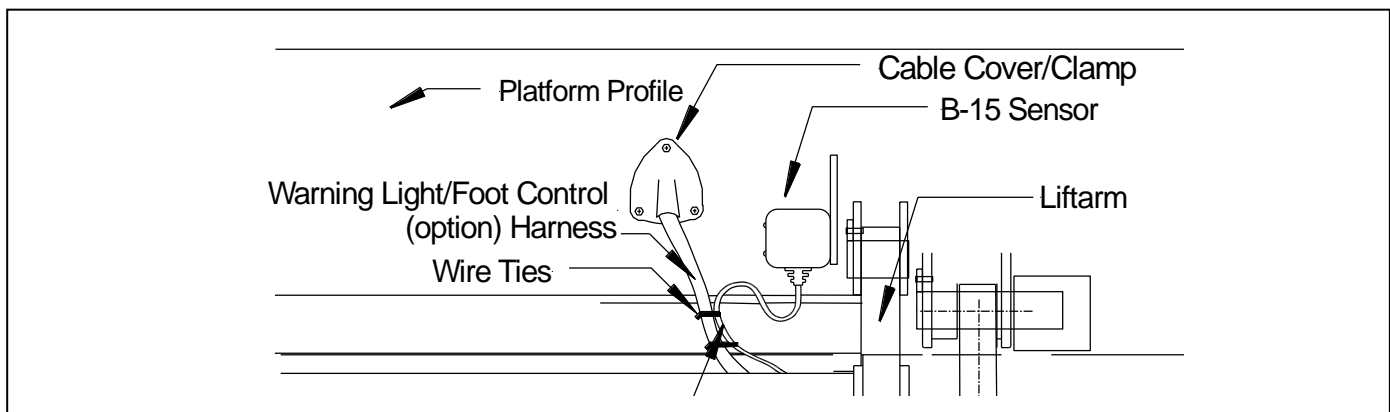

Figure 19 Platform wiring with B-15 and controls

6.3 Platform adjusting with bolts

At the bottom between the main and the tip section are 4 bolts to adjust the platform. These adjusting bolts are horizontal to the platform. To level the platform the bolts need to be adjusted. To tilt the tip section up the bolts have to be rotated counter clockwise. To tilt the tip down the bolts have to be rotated clockwise.

To adjust the bolts the platform needs to be folded.

1. Adjust bolts to the right length for a level platform
2. Tighten down the lock nuts properly for a secure fit.

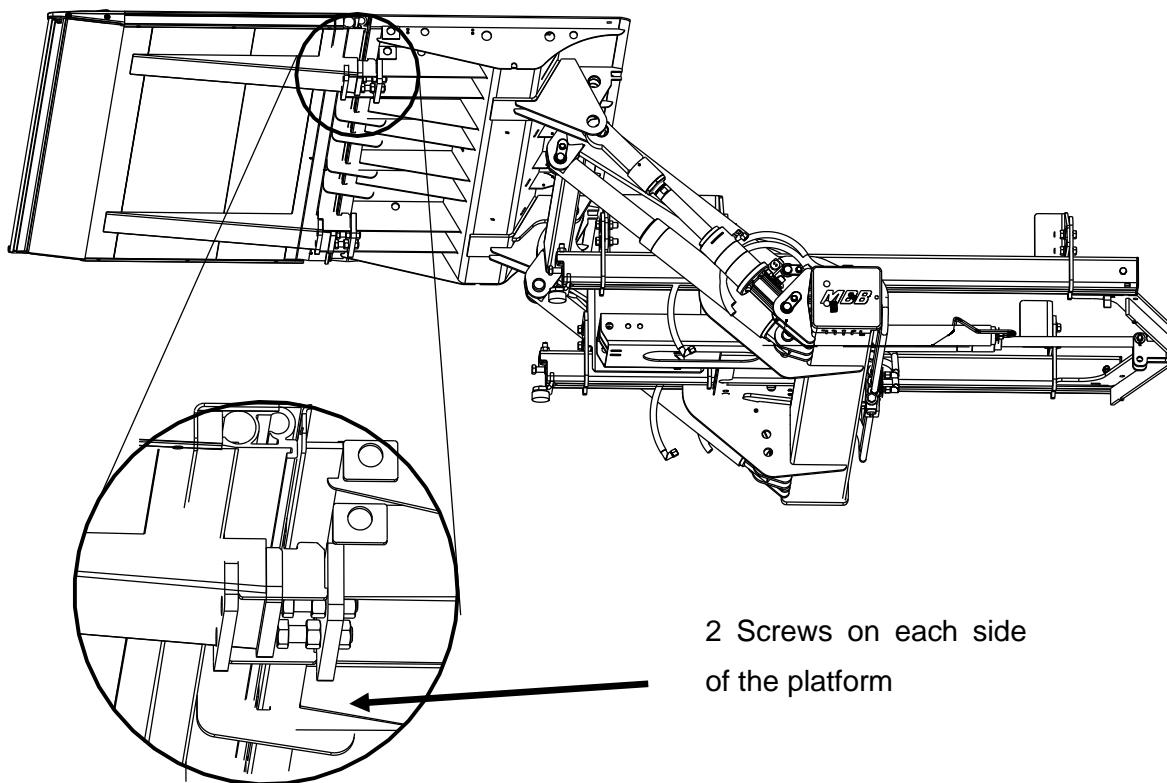

7 Electrical Installation

When performing electrical installation, be certain to install and secure everything in a way where it is not subject to damage from moving parts, sharp edges, exhaust systems, etc.

⚠ WARNING

- ANY deviation from INTERLIFT Liftgates' recommended power setup (see 7 Electrical Installation) will **void warranty and product liability** unless you have a written confirmation by INTERLIFT Liftgates that allows you to do specific changes.
- Never tie the power cables to gas or diesel lines on trucks – it is a fire hazard.

NOTICE

- Never exceed rating of existing fuses located at the battery, control board and/or the pump and motor which may result in serious damage to the equipment.
- Never jump the 150 Amp circuit breaker at the batteries unless otherwise instructed by the INTERLIFT Liftgates technical support center
- Ensure all connections are tight and securely fastened
- Heat shrink any connection to all cables.
- Never secure a cable in a way where it can make contact with other wiring, brake-, fuel- or air-lines etc. or get pinched against other objects.

7.1 Breaker Installation

- Mount circuit breaker securely in battery box or at positive battery post using supplied buss bar
- Connect liftgate 2Ga. cable to open stud on circuit breaker
- Connect 2Ga. jumper from open stud on breaker to positive battery post if circuit breaker was not mounted straight at battery with buss bar

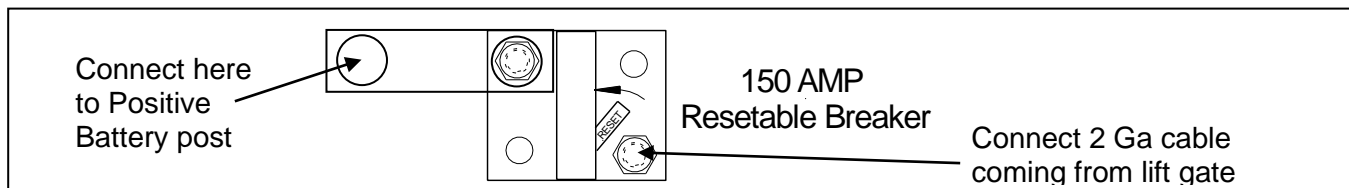

Figure 20 Circuit breaker installation

7.2 Wiring schematic main battery power - Truck

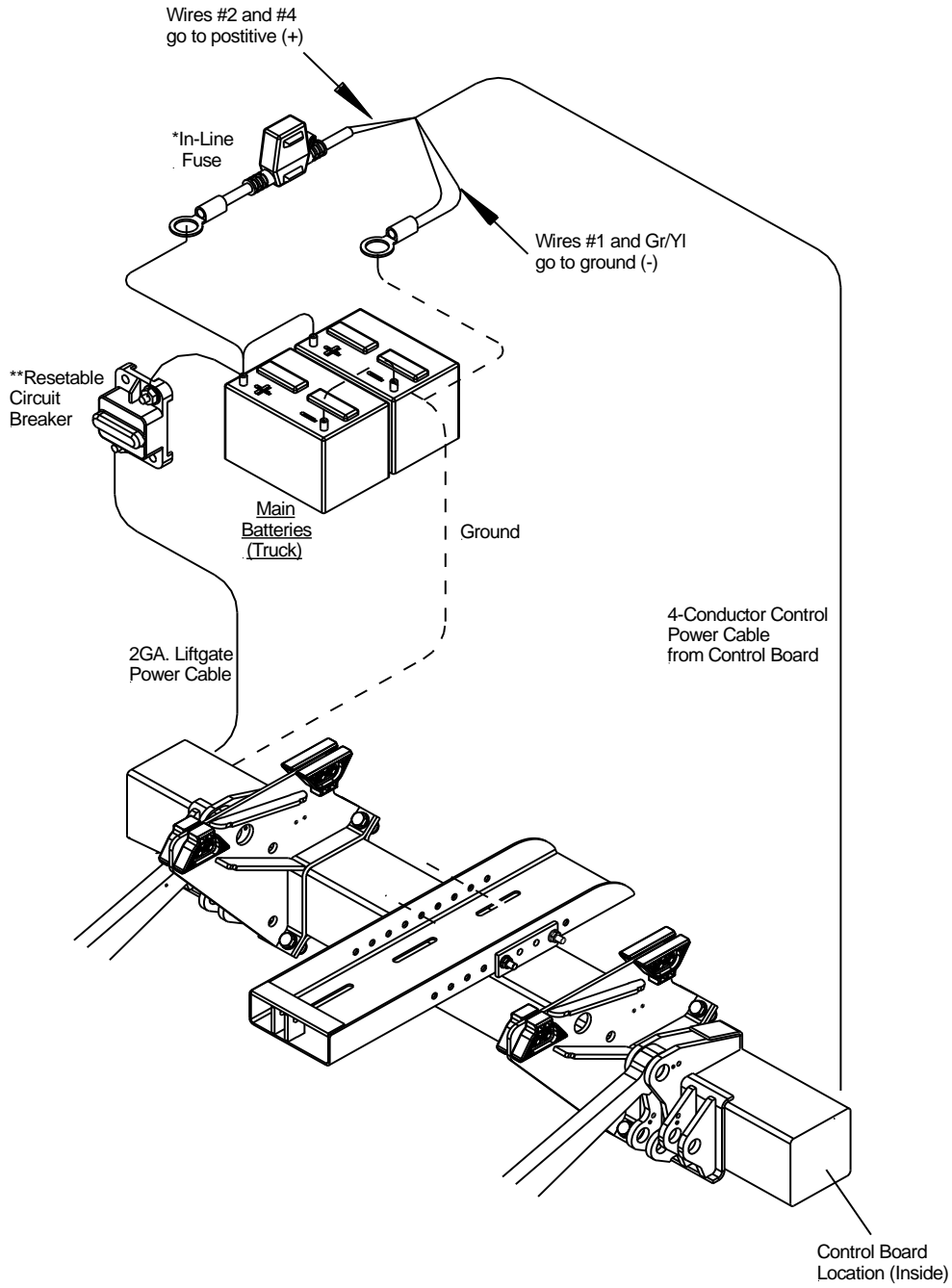

Figure 21 Main wiring - Truck and Trailer Setup

7.3 Wiring schematic main battery power - Trailer setup

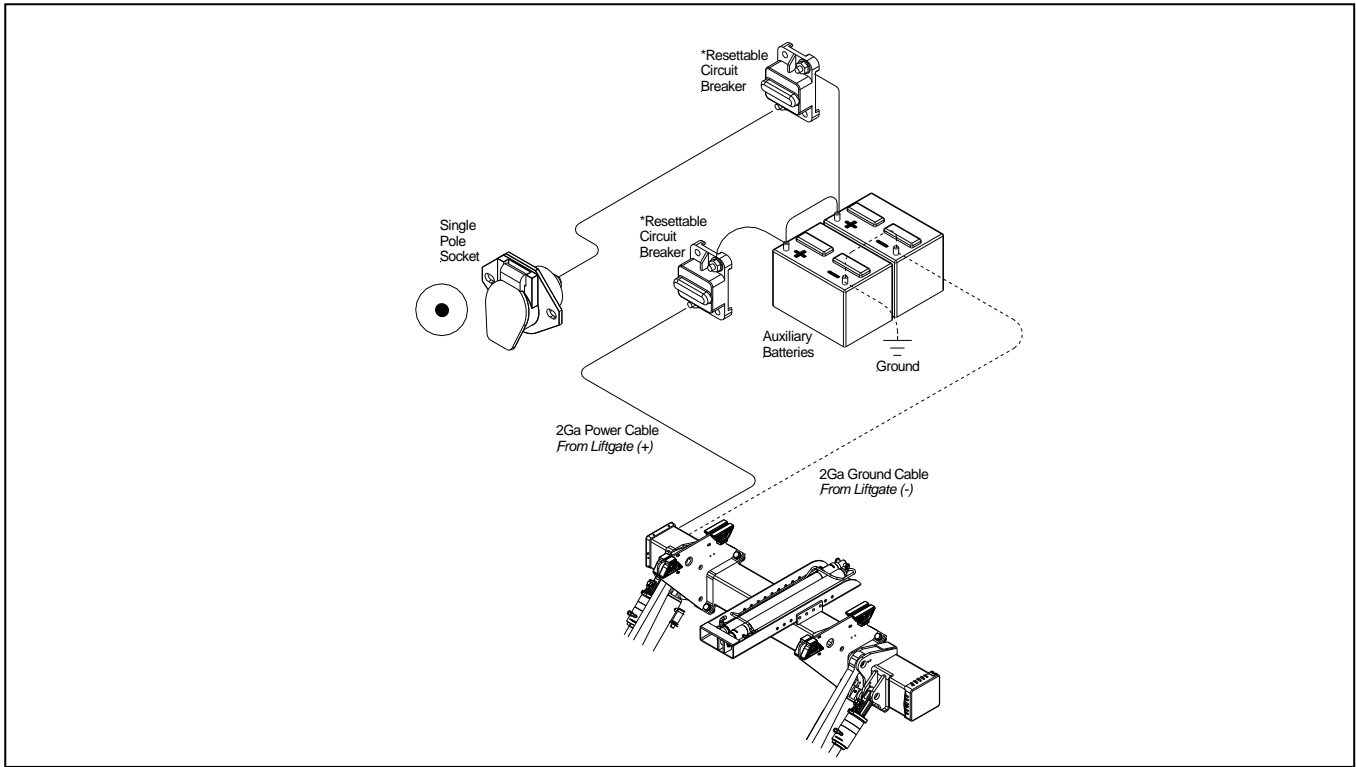

Figure 22 Main wiring - trailer setup - single pole charging system

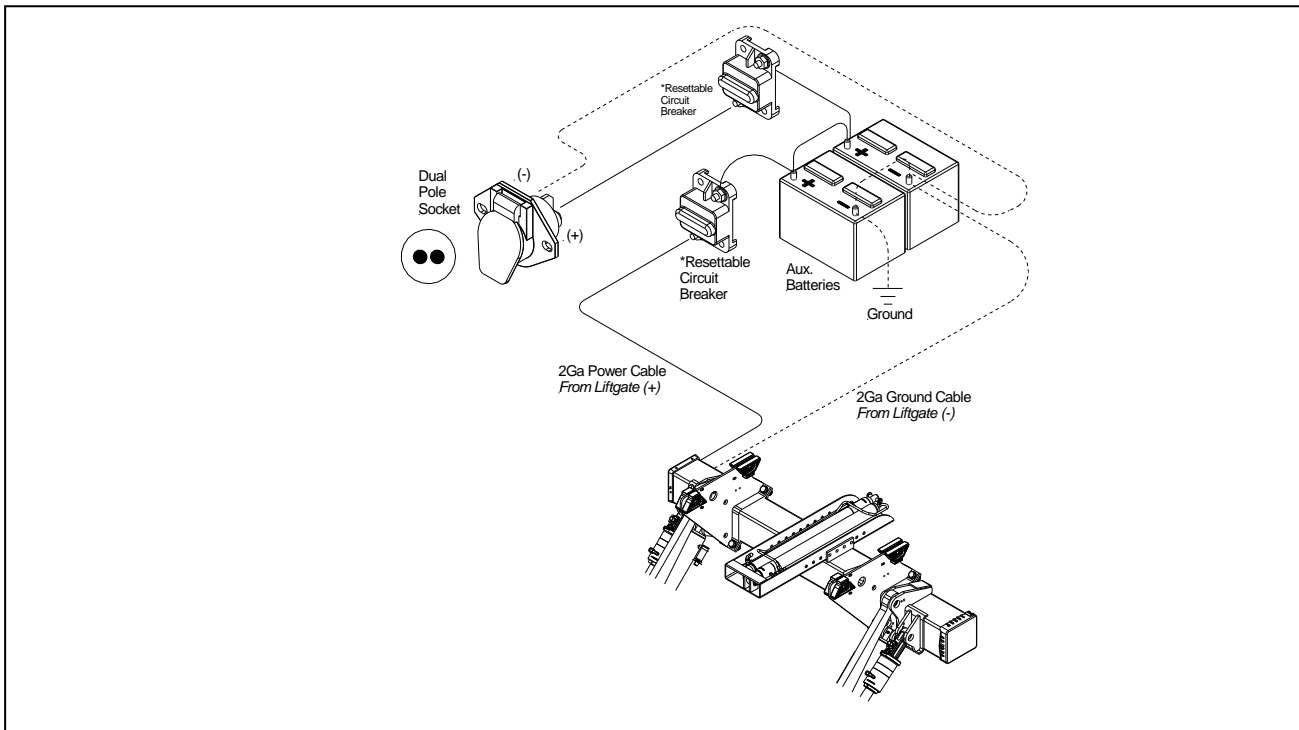

Figure 23 Main wiring - trailer setup - dual pole charging system

7.4 On/Off Switch Installation

7.4.1 Truck Setup

Lead the 4-wire cab switch (J-11 plug) together the 4 wires for the control power (**J1 #2 and #27; J2 #“-“**) to the batteries along the sub-wood, run the battery cable to the auxiliary batteries (if no aux. kit ordered, run battery cables also to the truck battery). Secure the cable every 12 inches against the sub-wood with cable staples. Run the cab switch only into the cab.

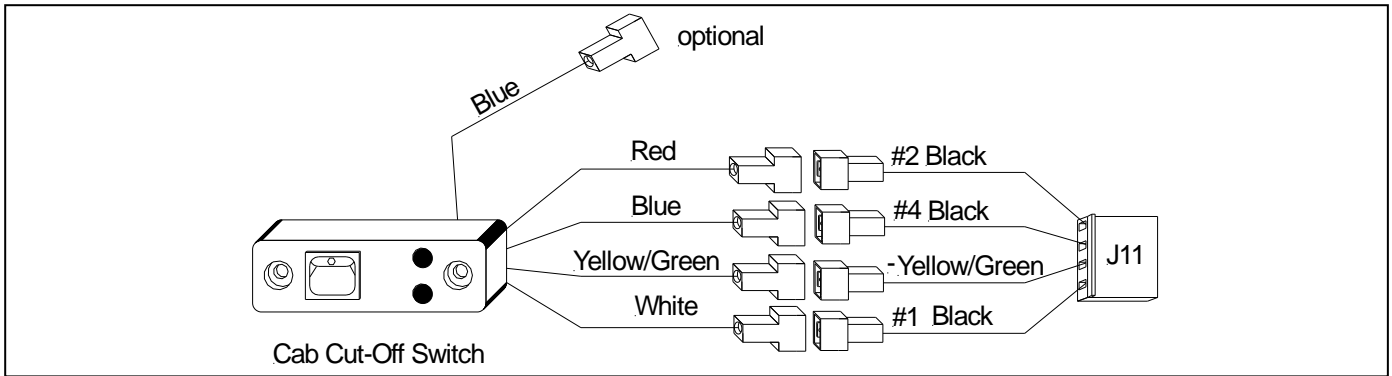

Figure 24 Cab Cut-off switch connection

7.4.2 Trailer Setup

Trailer units do not have a cab switch. The on-off switch is integrated into the control box. The switch is on the right hand side in the control box. It is prewired and does not need any additional work.

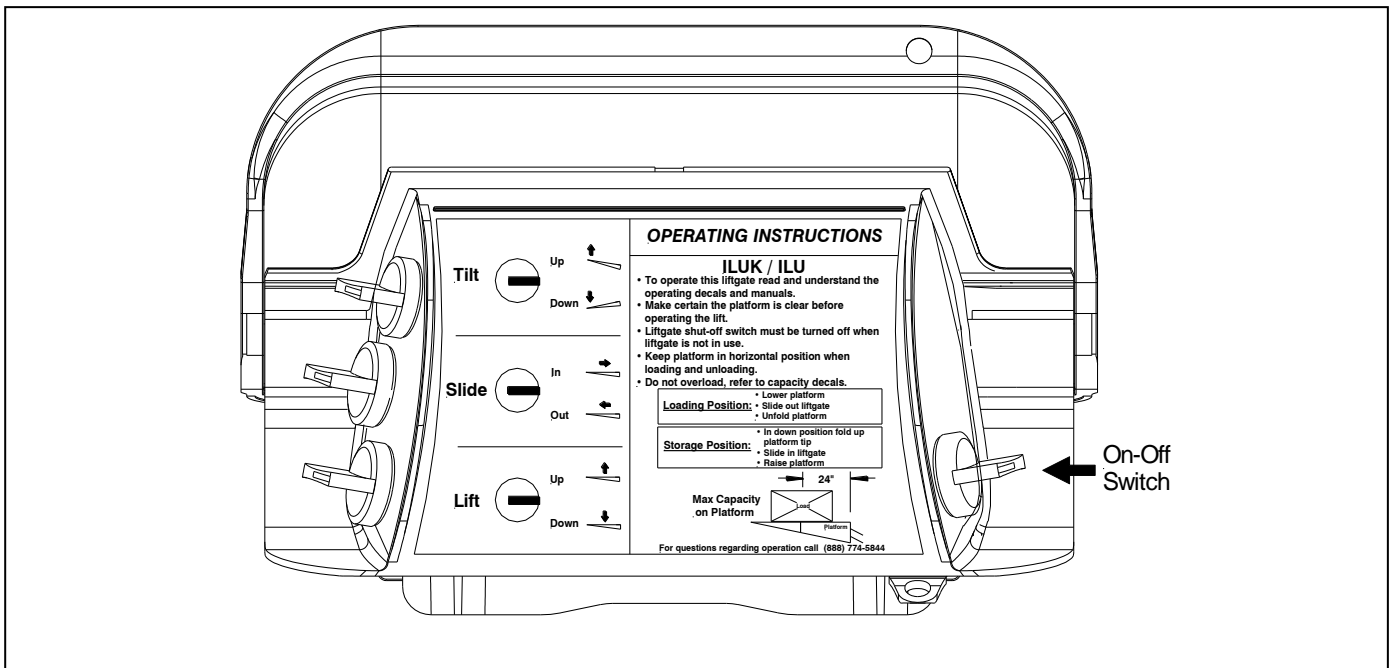

Figure 25 On-Off Switch - Trailer

7.5 Control Board Wiring and Connector Setup

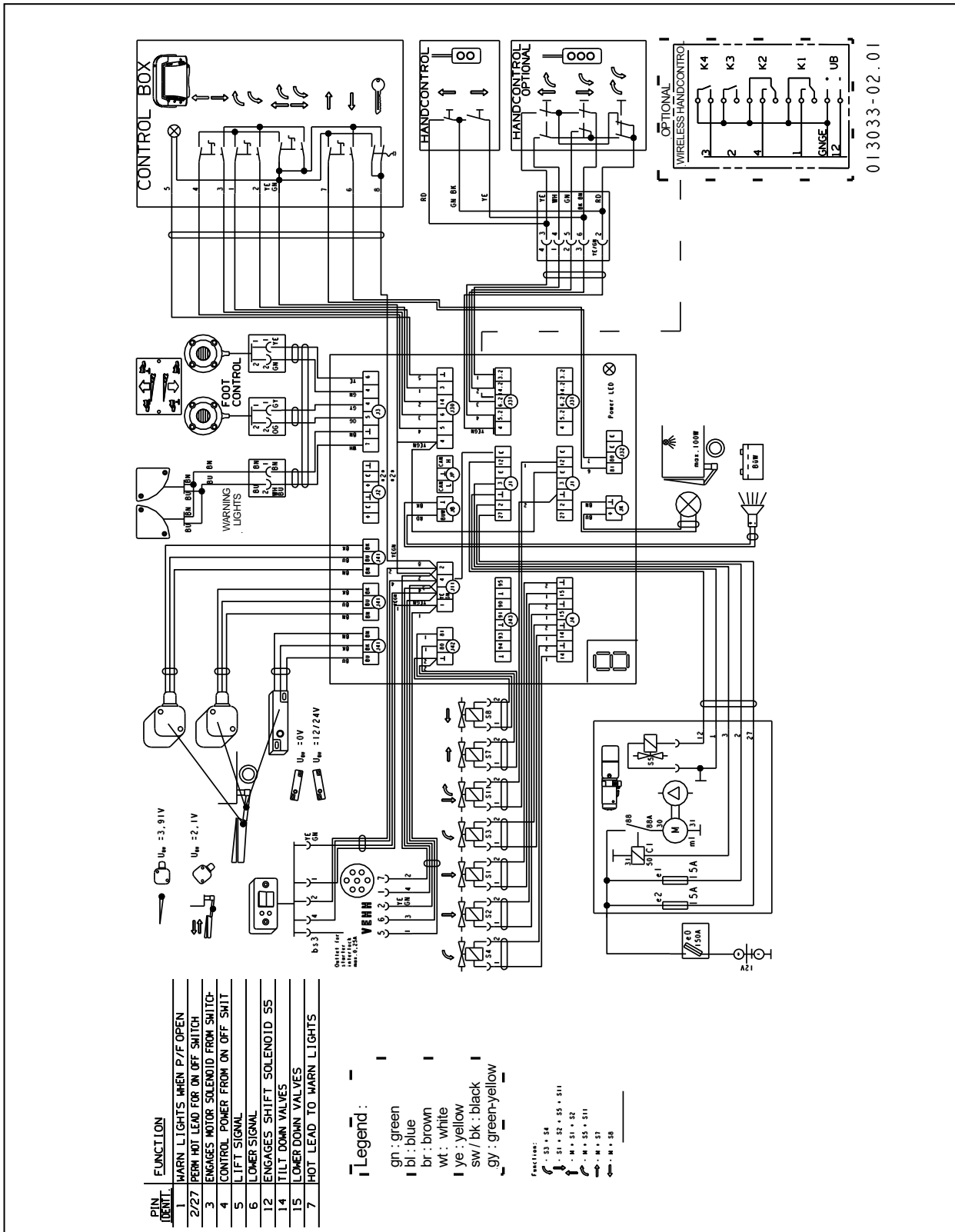
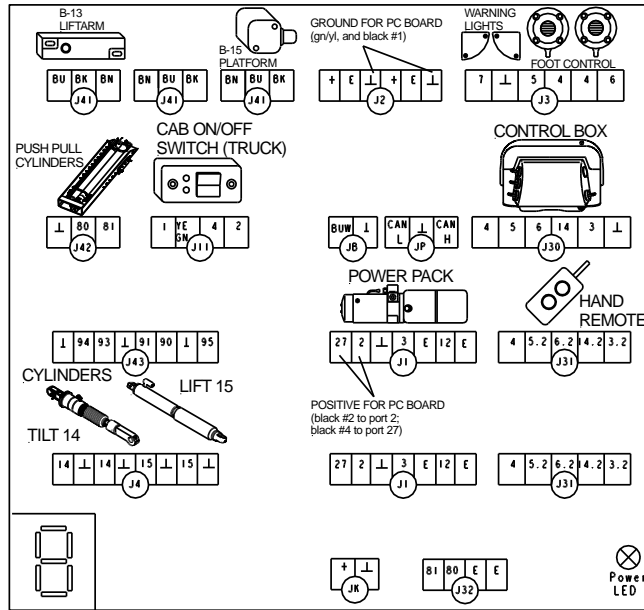

Figure 26 Control board wiring schematic

7.6 Control Board Plug Setup and System Codes



Code:	Description:	Reason:	Solution 1:	Solution 2:	Solution 3:	Solution 4:	Solution 5:
0	System OK / Control System: OFF	System OK / Control System: OFF	System OK / Control System: OFF
1	System OK / Control System: ON	System OK / Control System: ON	System OK / Control System: ON
2	Low Voltage	Voltage J1 Pin 2 too low	Check J-1 & J-2 power cable at PC board and battery for tight connection, oxidation and damage.	Check the battery condition / battery charged	Motor could have worn carbon brushes / motor could be bad
3	Liftarm sensor (B-13): Broken wire, short	J41-C shorted; J41 pin BLUE: wire getting more than 5 Volts (right upper location J41)	Check adjustment B-13	Check sensor for signal Blue wire with platform 10'-12" off ground	Change B-13 liftarm sensor
5	Platform sensor (B-15): Broken wire, short	J41-C shorted; J41 pin BLUE: wire getting more than 5 Volts (right upper location J41)	Check adjustment B-15 platform	Unplugged, plugged in wrong location	Change B-15 platform sensor	To temporary by-pass, jump Black to Blue	..
6	Short on warning lights	Power consumption J3 Pin 7 to high	Check J-1 & J-2 power cable at PC board and battery for tight connection, oxidation and damage.	Check warning light cables for damage
7	Short in cab Switch, control system	Power consumption J11 Pin 1 to high	Check J-1 & J-2 power cable at PC board and battery for tight connection, oxidation and damage.	Check cab cut off/ warning light cable for damage
8	General Short in electric wiring	General power consumption to high	Check J-1 & J-2 power cable at PC board and battery for tight connection, oxidation and damage.	Unplug wires one by one, check for correct plug location	Repair cables, connections, check for burnt or crushed wires
9	Defect in motor solenoid during lifting	Power consumption J1 Pin 3 to high	Check J-1 & J-2 power cable at PC board and battery for tight connection, oxidation and damage.	Check the battery condition / battery charged	Possible short in diode jumper wire on Motor Solenoid: Remove Jumper	Possible short in Thermo Switch inside motor Bypass and test, replace Thermo Switch	..
A	Fuse 15A damaged on power pack (J1, Pin 2)	Defective fuse J1 Pin 2	Check fuses at power pack	Check fuse holder Replace fuse with same amp fuse
b	During opening, an error was recognized on the valve spool for opening (S3/S4) or at the motor solenoid. NOTE: ONLY APPLIES TO ILK CANTILEVER LIFTGATE.	Power consumption J1 Pin 3 to high; ohm reading J4 pins 14 have changed	Check J-1 & J-2 power cable at PC board and battery for tight connection, oxidation and damage.	Check the battery condition / battery charged	..	Check ohm reading of the coils	Change coils or cables
c	During closing, an error was recognized on the motor solenoid or on the valve spool S-5. NOTE: ONLY APPLIES TO ILK CANTILEVER LIFT GATE.	Power consumption J1 pin 3 too high; ohm reading J1 pin 12 has changed	Check J-1 & J-2 power cable at PC board and battery for tight connection, oxidation and damage.	Check the battery condition / battery charged	..	Check ohm reading of the coil motor solenoid	Change coils or cables
d	During lowering, an error was recognized on S-1/S-2 lowering valves or valve spool S-5	Resistance J1 pin 12 has changed; ohm reading J4 pins 15 have changed	Check resistance of the coils	Change valve coils and cables	..	Check ohm reading of the coils	Change coils or cables
e	Emergency mode active (all logic functions and comfort functions are switched off)	Activate by pressing OPEN and LOWERING button (and Second Hand if in use) simultaneously for over 10s	Deactivate by turning cab switch or on off switch OFF then back ON
p	Error diagnostic mode active	Attached service plug
	NOTE: ILK, B-15 Sensor wire points toward ground when platform stored vertical NOTE: ILF, ILU, ILUK b-15 sensor wire points toward front of vehicle when platform is up at bed level	NOTE: B-13 sensor wire points toward front of vehicle NOTE: Purple side of sensors always face outward, where you can see purple			To Clear Code: 1. Unplug J-11 and plug back in 2. Cab switch off and on to clear code		

Figure 27 PC Board and System Codes

7.7 Control box wiring (internal)

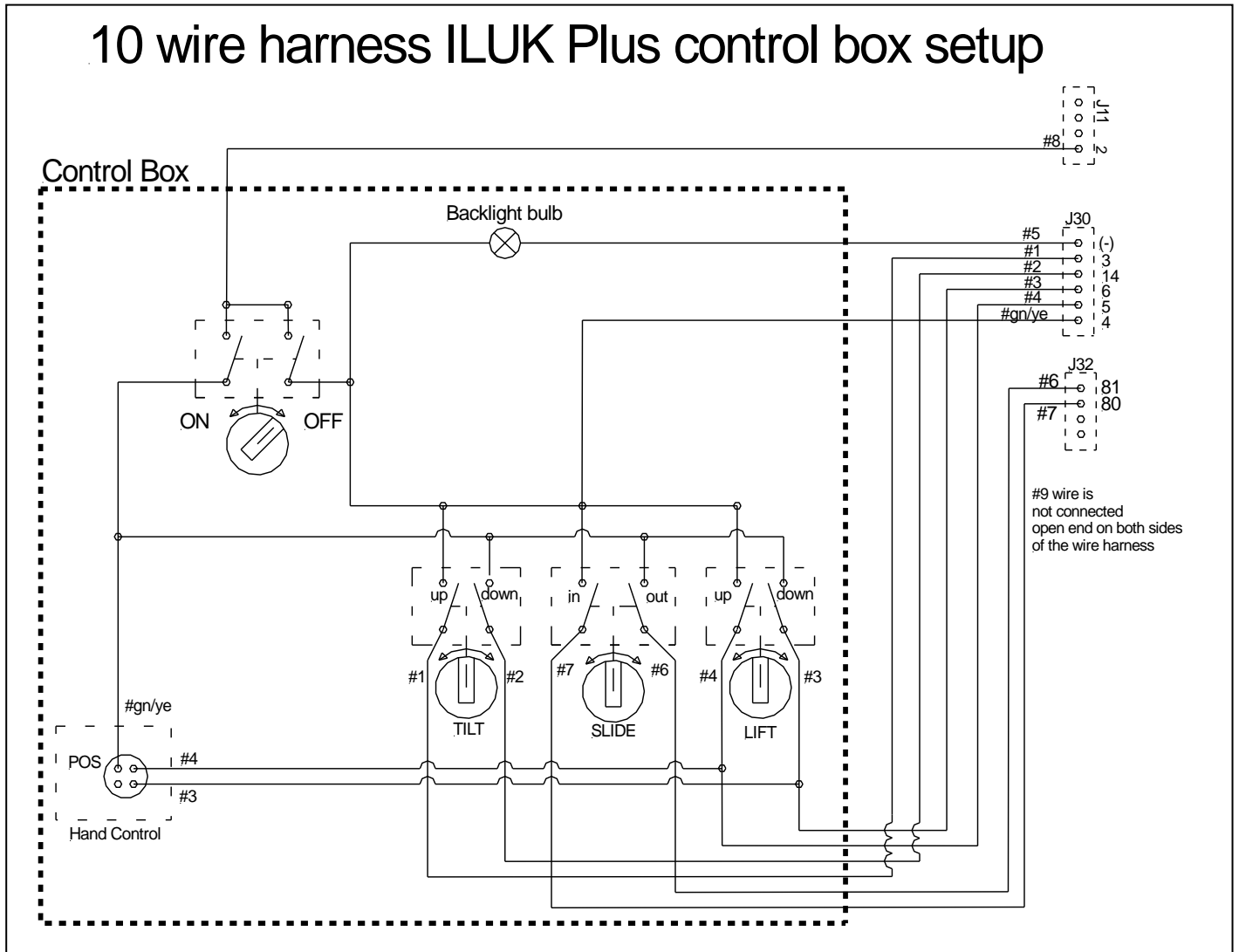

Figure 28 Control box wiring schematic

- J-2 #2: Main Battery power
- J-30: Control box PC-board input gate operation functions
- J-32: Control box PC-board input gate sliding functions (#80 slide in; #81 slide out)

7.8 2 Button Remote Hand Control

The hand held remote control plug is integrated into the control box. No separate wiring is needed.

Wire coding inside hand control:

- UP - RED
- DOWN - YELLOW
- 12V HOT - GREEN

8 Hydraulic schematic

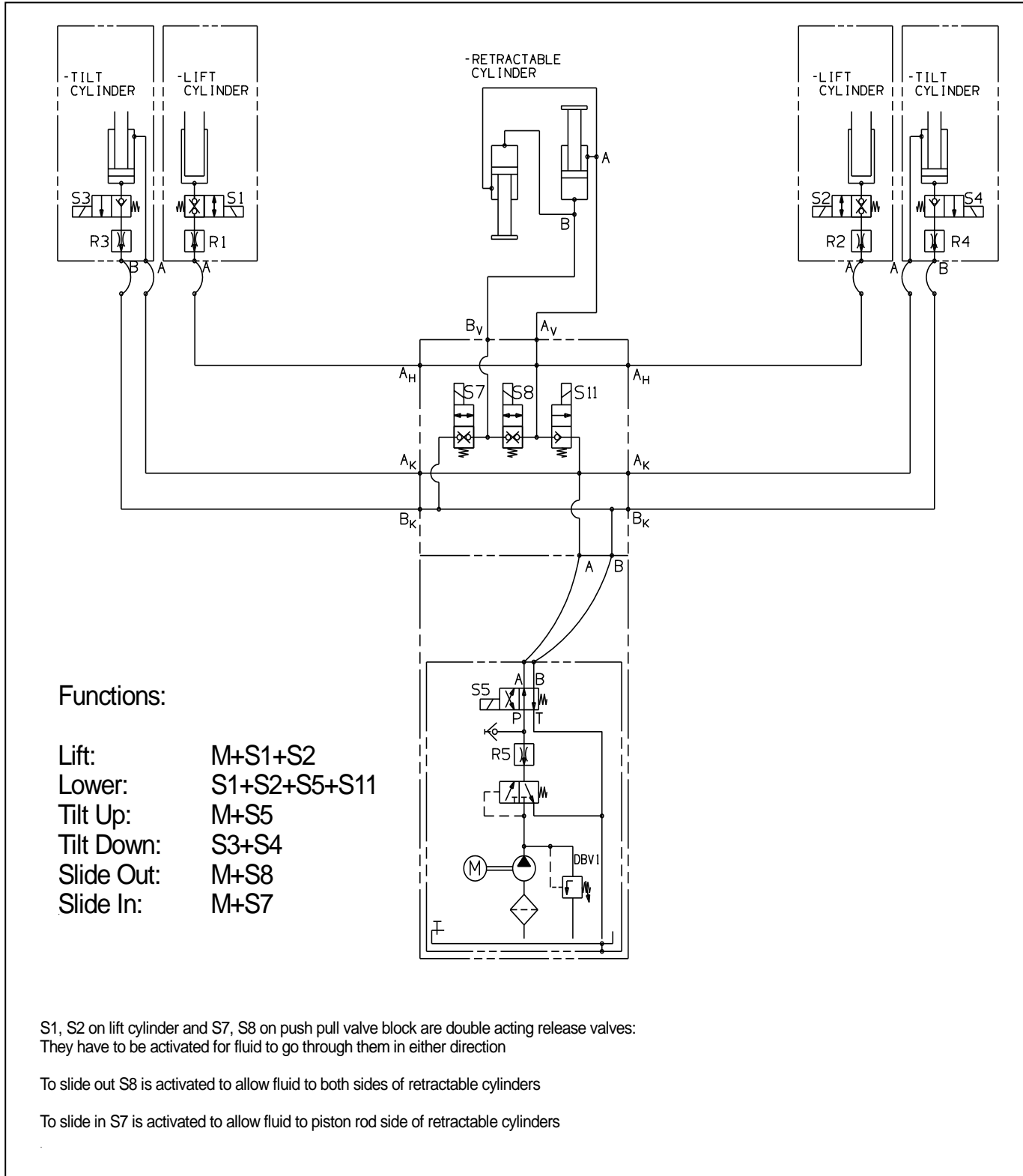

Figure 29 Hydraulic schematic ILU

8.1 Lubrication

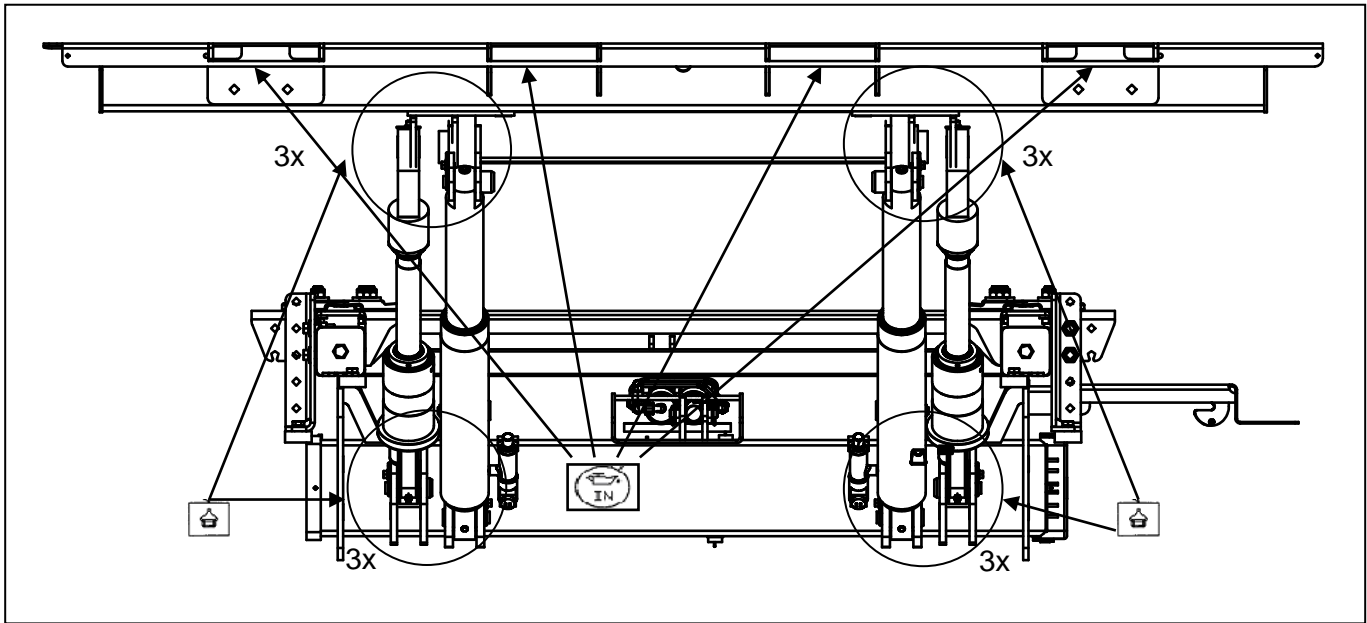



Figure 30 Grease and Lubrication points

 Location of Grease Zerks (6 on each side, 12 total)

 Oil level in the power pack tank (see marking inside of power pack reservoir)

 Platform hinges, Slide Rails and optional Cart Stops (use WD-40 spray for lubrication)

- Open platform and raise lift gate to bed level
- Remove red caps, apply grease until grease begins to flow from bushing ends
- Lower platform to ground and repeat
- Cycle platform open and closed several times and grease again
- Wipe excess grease from joints and replace ALL red caps

9 Decal Placement

For operator’s safety, all decals appearing in “Decal Kit” must be in a conspicuous place on control side of liftgate to be read by operator. This is typically a combination of decals on the liftgate and truck body. Please make sure to place the maximum capacity decal (D) on driver and curb side.

- (A) 1 ATG-URGWA - Urgent warning: Elevating gate instructions
- (B) 1 ATG ILU - Operational Instructions (placed on your Control Box).
- (C) 1 ATG-FT - Notice for Foot Control (if applicable)
- (D) 2 ATG-XXXX - Max. Capacity (please check the serial number plate to find out your specific capacity)
- (E) 1 ATG-CAB - Liftgate Shut-Off (must be placed next to the Shut-Off Switch)
- (F) 2 ATG-WLH - Warning: liftgate can crush
- (G) 2 ATG-CTN - Caution: Always stand clear of platform area
- (H) 1 ATG-BKR - Circuit Breaker Reset (must be located at the circuit breaker)
- (J) 1 ATG-RESET - Circuit Breaker Protection
- (K) 1 ATG-UD - Toggle Decal
- (L) 1 ATG-WNG - Warning: Use handle to open (must be located underneath handle (main section))

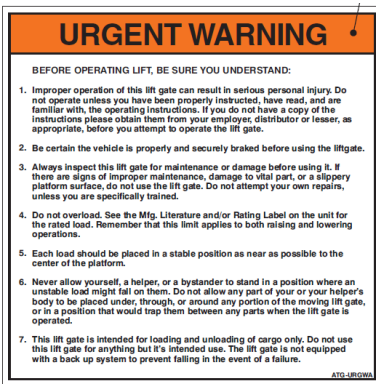

Decal - A



Decal - D

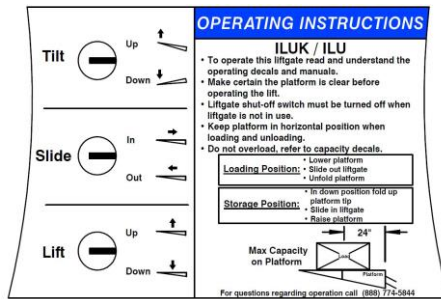

Decal - B

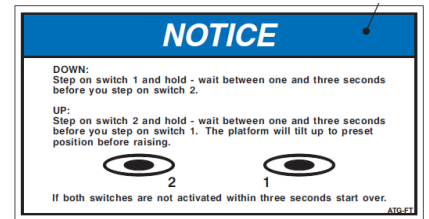

Decal - C



Decal - F



Decal - G



Decal - E

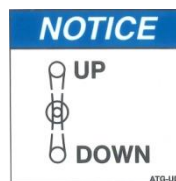

Decal - K

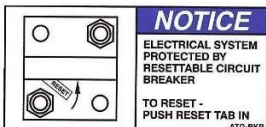

Decal - H



Decal - J

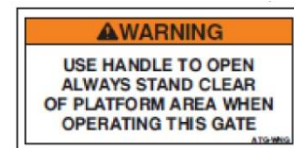

Decal - L

The picture below will help you to place all decals visible in order to get maximum operational safety.

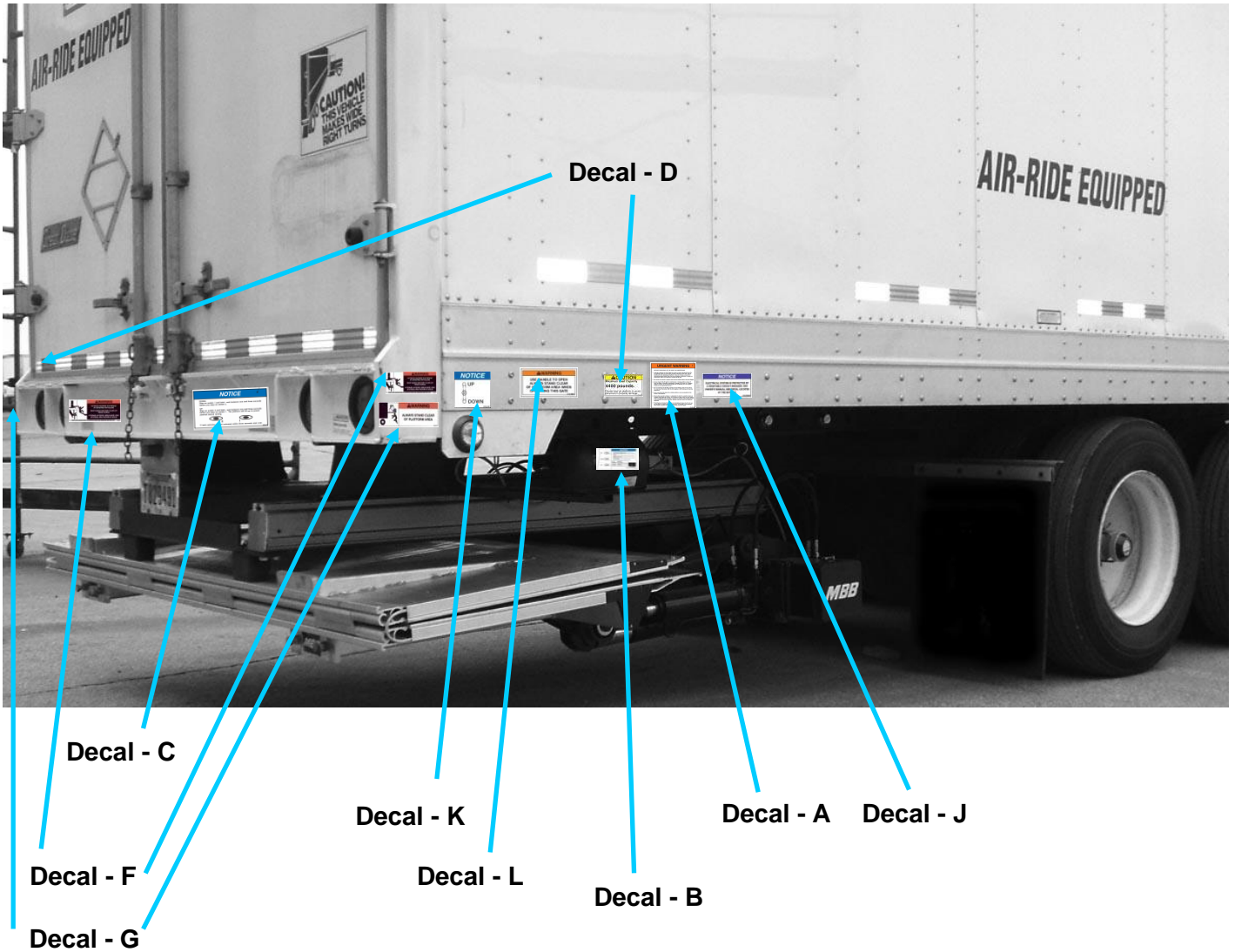

10 **Final Inspection Check List**



Liftgate failure or malfunction could result in property damage, personal injury or death if you fail to check each of the following items listed. **DO NOT USE** the liftgate if any of the following points are **NOT** verified and checked.



Installation is **NOT** complete and all **WARRANTIES** are **VOID** if you have not checked and verified all items listed on this inspection sheet. Inspection sheet is to be filed at the facility where liftgate was installed.

Structural Inspection

- All welds are 100% complete per this manual.
- All nuts, bolts, mounting hardware, pins, chain anchors are tight.
- All mounting dimensions are correct and liftgate is square and parallel per this manual.
- Lift arm upstops are installed.

Hydraulic Inspection

- Pump reservoir is filled to 1.5" from top when cylinders are completely compressed (platform is resting on the ground).
- Hydraulic components and connections do not leak.
(Should be checked after unit is hydraulically locked for five (5) minutes.)
- All hydraulic lines are secured with cable ties, hoses clamps, or other fasteners. No hoses or components rub on the frame, platform, or any other components while unit is in operation or in storage. No hoses are kinked or bent.

Electrical Inspection

- Battery cable(s) attached are clamped tight and dielectric grease is used to seal all connections.
- All electrical lines are secured with cable ties, hoses clamps, or other fasteners and are away from sharp edges and moving parts.
- Circuit Breakers installed and wired per instructions.
- Battery voltages: Flooded Batteries = 12.6V; AGM Batteries = 12.8V
- Lights wired properly and operate per DOT, State, and Federal requirements.

Operational Inspection

- All decals are in place and legible per instructions.
- All pivot points are lubricated per instructions, and Zerk fittings have been capped.
- Platform travels up and down smoothly and freely, without any hesitation or unusual noises.
- Platform is flush with the sill/floor when raised completely.
- Liftgate and platform slide in and out without any hesitation or unusual noises.
- Platform rests on the rollers evenly when lowered completely and tilts when operator uses the tilt function.
- Platform raises and lowers properly and at correct speed. (2 to 4 inches per second)
- Gate is painted, body is clean around gate. Cylinders are clean and rubber & plastic caps are in place.
- The liftgate serial number and model number are documented on the inside of the front cover of the Owner's Manual, as well as the installation manual in the space provided.
- Owner's Manual is in the vehicle's glove box.
- Supervisor has demonstrated the instructions in the Owner's Manual to the customer/driver upon delivery.

Inspection Information:

Name (please print): _____

Completed by (signature): _____

Title: _____ Date: _____

