

ETC MH 40 IH

ARTICULATED / TELESCOPIC
INSULATED MATERIAL HANDLING



INSULATED VERSATILITY

The ETC MH 40 IH is a versatile insulated unit that is well suited to those customers in need of an aerial unit that can offer powerful capabilities. With an articulating and telescoping aerial lift that reaches a height of 40' to the bottom of the bucket, this unit has a standard option continuous rotation allowing for unrestricted rotation. This model also offers material handling capabilities with a hydraulic winch and a 3' jib that can lift up to 1,000 lbs.



DEPEND ON IT.



ETC MH 40 IH

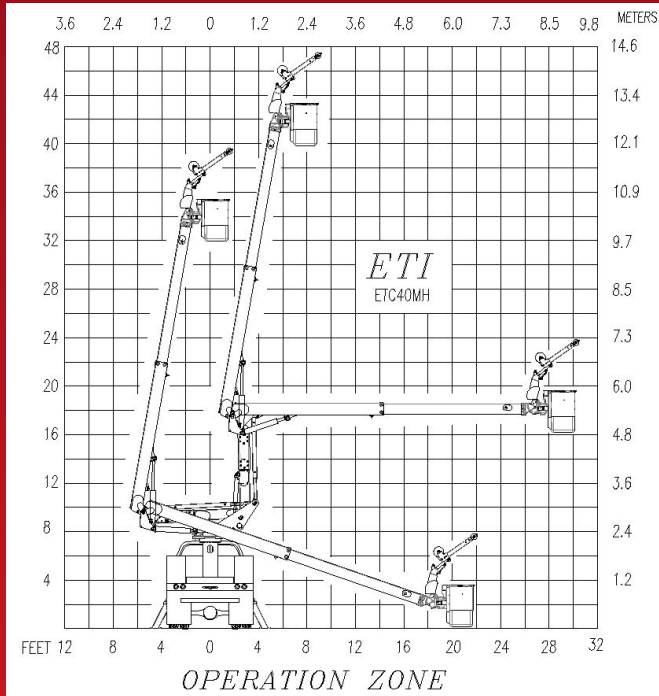

**EQUIPMENT TECHNOLOGY LLC
IS A FULL SERVICE SOLUTION
PROVIDER OF THE HIGHEST
QUALITY DESIGN,
MANUFACTURING, AND POST
SALE SERVICE.**

EQUIPMENT TECHNOLOGY LLC

341 NW 122nd
Oklahoma City, OK 73114
Toll-Free: 1-888-748-3841 • Fax: 1-405-755-6829
etiequipment.com

GENERAL SPECIFICATIONS*

Height to bottom of bucket	40 ft. - 0 in.
Working height	45 ft. - 0 in.
Side reach, End mount	30 ft. - 0 in.
Rotation	Continuous
Lower boom articulation	-3° to 89°
Upper boom travel	-23° to 80°
Stow height	10 ft. - 2 in.
Rated bucket capacity	400 lbs.

MINIMUM VEHICLE SPECIFICATIONS

- GVWR 19,500 lbs.
- C.A. 84 in.

STANDARD FEATURES

- Continuous rotation is standard providing unrestricted rotation.
- Lower boom compensating link.
- Full pressure hydraulic controls located at platform and turret with full feathering capabilities from upper and lower controls.
- Hydraulic leveling via master/slave system providing a bucket dump for clean out and operator rescue.
- Shear ball rotation gear driven by external drive gear box. The gear box has an extended hex shaft for manual rotation.
- Internally mounted holding valve (integral part of cylinder) locks cylinder in place in event of hydraulic failure.
- All pins turn on replaceable composite bushings.
- Inner boom extend with double acting hydraulic cylinder for safety and performance.
- 180 Degree bucket rotator
- Single handle hydraulic control at basket.
- Fiberglass upper boom, fiberglass insert on lower boom.
- 24"x 30" Basket
- Outrigger/boom interlock
- 400lbs. Bucket capacity
- Hydraulic winch & 3ft jib — up to 1000lbs. material handling
- Dual hydraulic circuit

OPTIONS

- Engine start/stop at bucket
- Emergency hydraulic power (12VDC)
- Bucket liner
- Bucket cover



Specifications are subject to change without notice

Note (*): All specifications are based on 40" frame height