

PALFINGER

PALFINGER HT 08 – HT 07 S

A MID-RANGE HOOKLOADER IN THE BIG LEAGUE

LIFETIME EXCELLENCE



DESIGN & DEVELOPMENT FOCUSED ON SAFETY, RELIABILITY & USER-FRIENDLINESS



New hook shape

Easier catch and release of the container bar. Smooth sliding of the container bar inside the hook, reduces vibrations and thus also noise. The deep hook shape allows the safe horizontal movement of the container. Only available on HT 07 S.

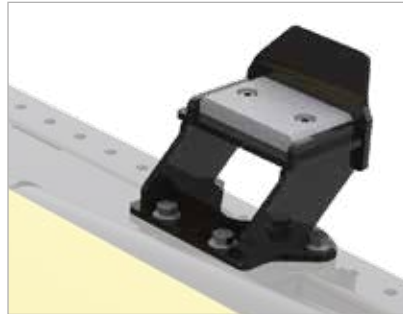

Soft sliding

Bolted container supports with integrated slide bearings allow a lower energy requirement as well as a reduced noise development during the horizontal movement of the container. Available as option.

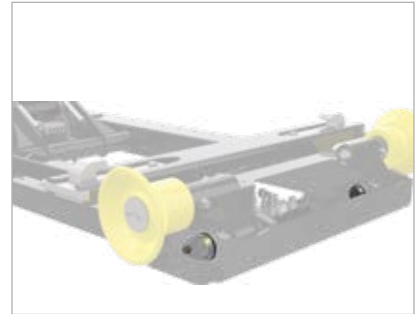

Bi-point concept

Improves the force transmission of the main cylinders and thus facilitates the tipping of heavy containers.

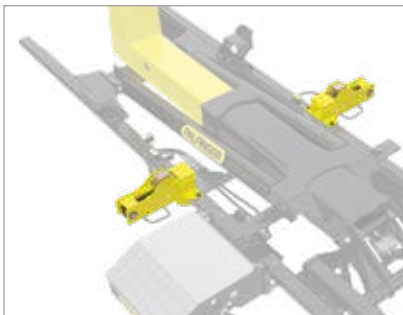

Front hydraulic locking

Front locking enhances stability during transportation of high containers or containers with a high center of gravity. It also allows loading of special containers (cranes on cradles, compactors on cradles, etc.). Bolted design for more flexible positioning on the subframe.



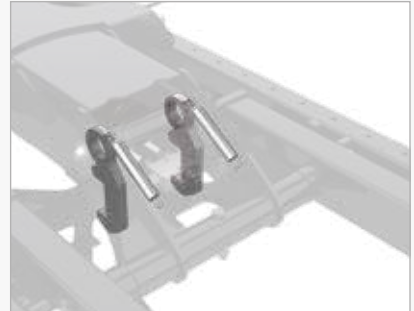

POP – Palfinger Origin Protection

Increased lifetime: before assembling the main components are sand-blasted, degreased, primer painted and electrostatically final coated (according to customer specification). All other parts are anticorrosion treated. According to ISO 12944 Class3.

Service friendly

Reduced service costs due to easy access to all wearing parts. Maintenance-free composite bearing bushes on all pins eliminate the need for regular lubrication and reduce maintenance to a minimum.

Safety

Tipping lock allows tipping even without a container and is therefore not dependent on the condition of the container. This also simplifies maintenance process.

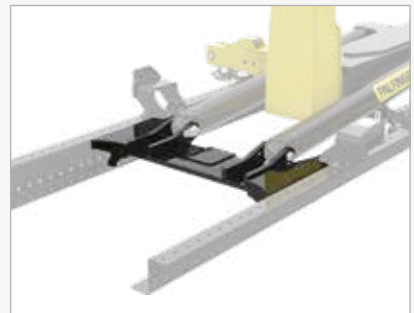

Easy mounting

Optimized design of the subframe allows easy installation on all common vehicle frames. An additional subframe between chassis and subframe is not required. This results in a reduced transport height and increased payload.



3 SERIES

TEC 5, SLD 5 AND SLD 3

CONTROL SYSTEMS



PAD TOUCH on TEC 5

PAD TOUCH control embeds the most advanced control system on TEC 5 units.

- Combination of touchscreen and compact cabin control eases single-lever operation and offers maximum flexibility and information.
- PAD Touch offers the convenience of a joystick control and the possibility to customize the control to your needs. Via the touch screen, the operator also has access to all device and service data at any time.
- TEC 5 includes a rear view camera as standard which is displayed via the touch screen – the system supports up to a maximum of 4 cameras.
- Optionally, the PAD Touch System can also be equipped with a radio remote control as well as the automatic function sequence “Auto-Cycle”.



PAD CONTROL on SLD 5

PAD control is a highly functional and efficient joystick control on all SLD 5 units.

- Integrated LEDs indicate the current PTO status as well as the safe transport position to the operator. A 3-digit LCD display also shows status and error codes.
- Optionally, PAD control can also be equipped with a radio remote control as well as the automatic function sequence “Auto-Cycle”.

EASY DRIVE on SLD 3

Easy Drive System offers simple and reliable control on all SLD 3 units.

- 2 variants with either 3 or 5 functions, depending on the equipment specification.
- 2 LEDs indicate safe transport position and system status.
- Automatic safety shutdown of the system, after 2 minutes without activation.
- Equipped with a simple diagnostic and emergency mode.

3 TYPES OF CONFIGURATION

SLD 3

SLD 5

TEC 5

Control system	Easy Drive	PAD	PAD TOUCH
Radio remote control	No	Option	Option
Soft stop	Option	Std	Std
Mainvalve	SDM110	SDS150	SDS150
Auto-cycle, truck communication, stop button, multi-lightening	No	Option	Option
Pack-vision	No	No	Std
Telematic	No	Option	Option
Screwed container rests – anti-friction	No	Option	Option
Final painting - POP	Option	Option	Option

TECHNICAL DATAS

HT 08

HT 07 S

Market standards	DIN - NF - ESP	KP7	CZ	NF - DIN
Hookheight	1570-1425-1350	1180	1000	900-920
Length (mm)	3550-3800-3950 4350-4750	3800	3550-3800-3950 4350	3550-3800-3950 4350
Capacity	8 t	8 t	8 t	7 t
GVW truck			8 to 12 t	
Average weight			900 kg	
Transport height			235 mm	
Tipping angle	48-54°	54°	51-54°	51-54°

KP-HT08HT07S+EN

Units shown in the leaflet are partially optional equipped and do not always correspond to the standard version. Country-specific regulations must be observed. Dimensions may vary. Subject to technical changes, errors and translation mistakes.