

SPS 17500 STIFF BOOM CRANE

IDEAL LIFTING SOLUTION FOR 2 & 3 AXLE TRUCKS



TECHNICAL SPECIFICATIONS

Product Description

- SANY PALFINGER produces according to European Quality Standards to ensure reliability, performance and safety in the industry
- High tensile strength extension booms to optimize lifting height and working range
- The wide outrigger span ensures stability in all mounting situations
- High safety factor with greater reliability
- Piston pump option for reliability, efficiency, and extended lifetime
- Standard package includes
 - Emergency stop button
 - Working light
 - High pressure filter
 - Over-winding stop

Technical Data

Basic Data	SPS 17500B
Rated Lifting Moment	19.8 mt
Rated lifting capacity	8000 kg (2.0m)
Max. outreach	13.5m
Max. lines of the hook	4
Slewing angle	Continuous
Boom raising angle	0 ~ 75°
Max. lifting height (the measurement from the ground after the outriggers fully extended)	15.3 m
Length of the boom system (retracted)	4.8 m
Length of the boom system (fully extended)	13.8 m
Boom sections	4
Outrigger span (fully extended)	5600 (mm)
Recommended Flow Rate	45 - 70 L/min
Operating pressure	28 Mpa
Recommended oil tank capacity	100 L
Crane moment (dynamic)	301.1 kNm 30.7 mt
Torsional moment (dynamic)	19.2 kNm 2.0 mt
Crane Weight	2730 kg (Floor Control)

LIFTING CHART

SPS 17500B

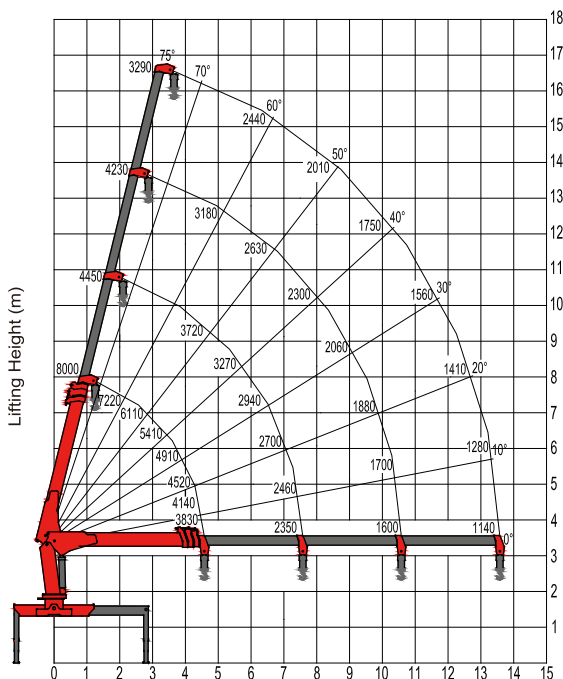

NOTE
 Load chart may be different based on crane options.
 The above lifting height and boom angles are based on a straight (unladen) boom.
 Allowance should be made for boom deflection under laden conditions
 Lifting capacities must not exceed 85% of tipping load.

CRANE DIMENSION

SPS17500B-F

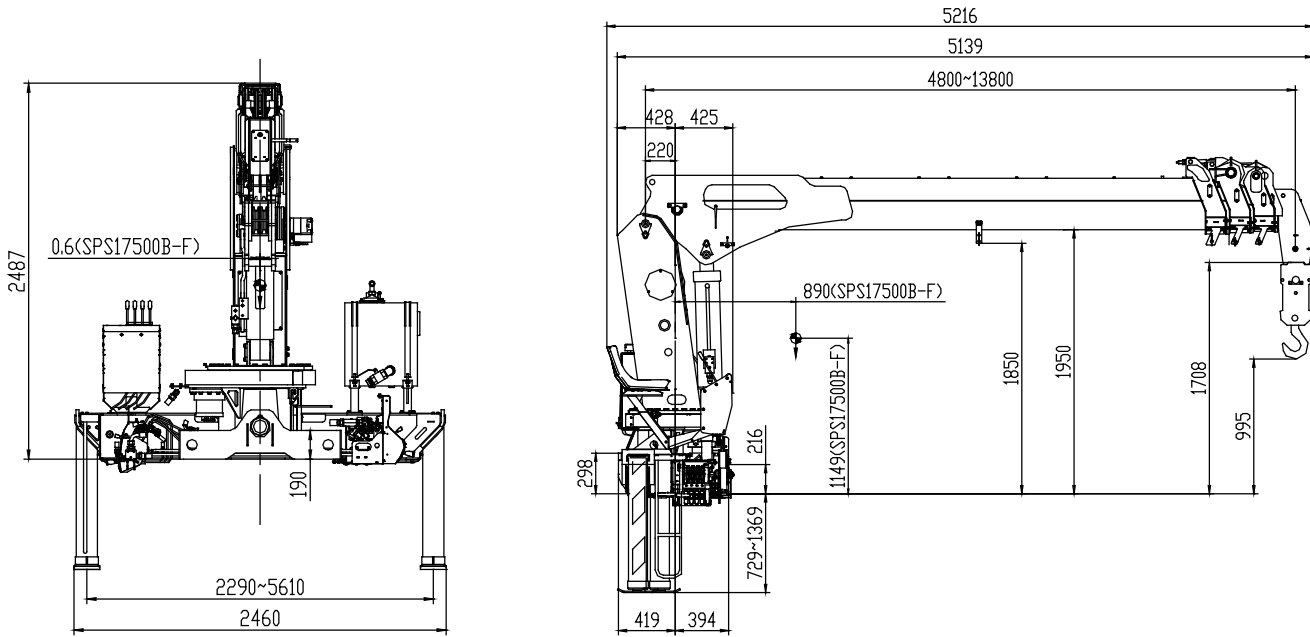

*The actual product dimensions can vary depending on the operational equipment.

FEATURES & OPTIONS



Octagonal Boom Profile

- High strength and rigidity due to octagonal cross section

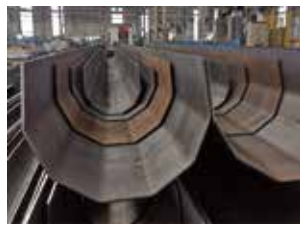

High Tensile Steel

- High Tensile Steel: HG785, SC960
- Able to withstand higher forces



Overload Protection System

- Built-in safety function
- Protects the crane against overloading



Working Light

- Safer operations in dusty and dark working conditions
- Optimal visibility for work



High Pressure Filter

- Ensures proper functionality and longer lifetime of crane



Proportional Hydraulic System

- Sensitive and stable controls for precise operation
- Operator is able to utilize multiple functions simultaneously



Load Indicator

- Provides operators with important information on possible overloading and lifting conditions

PALFINGER ASIA PACIFIC PTE LTD
3 International Business Park
Nordic European Center | #05-25/26
609927 | Singapore
T: +65 6591 9191
asia@palfinger.com

Cranes shown in the leaflet are partially optional equipped and do not always correspond to the standard version. Country-specific regulations must be observed. Dimensions may vary. Subject to technical changes, errors and translation mistakes.