

SPK 8500

PALFINGER

LIFETIME EXCELLENCE

PALFINGER ASIA PACIFIC KNUCKLE BOOM CRANES



SPK 8500

SPK 8500

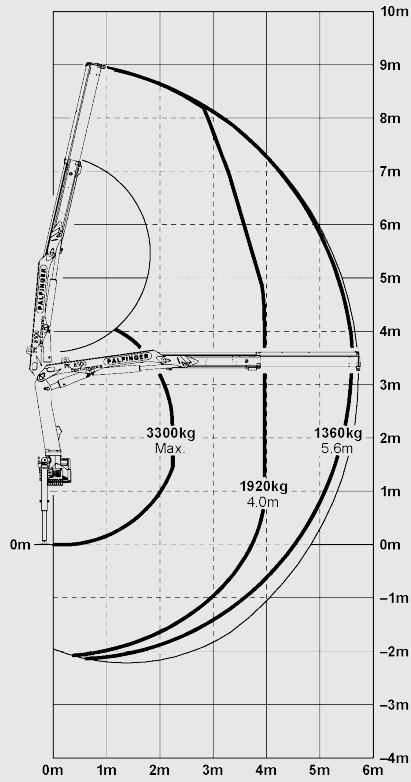

SPK 8500 A

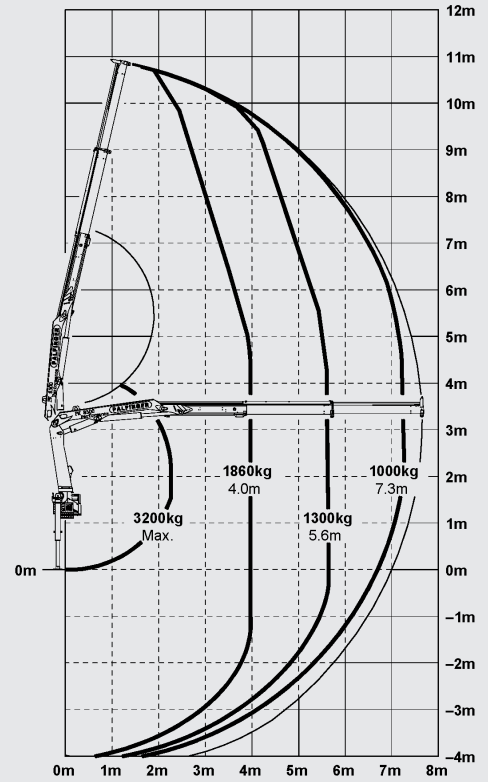

DIMENSIONS

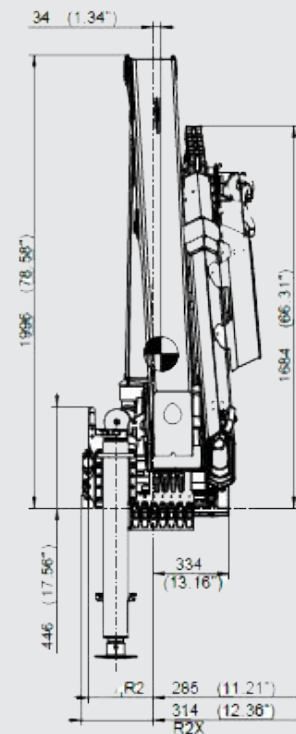
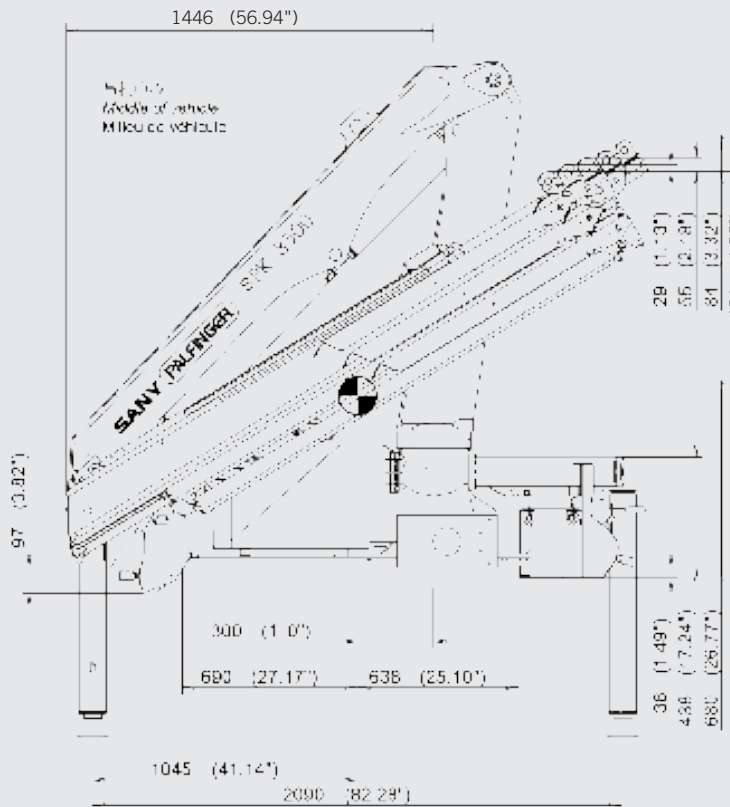

All dimensions are in mm

SPK 8500 B

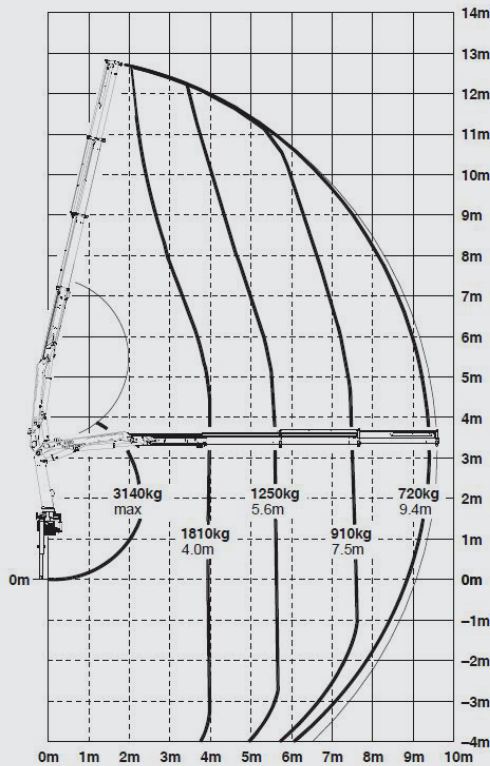

TECHNICAL SPECIFICATIONS (EN 12999 H1-B3)

Max. Lifting Moment	mt	7.6
Max. Lifting Capacity	kg	3300
Max. Hydraulic Outreach	m	5.7 (Std.) / 7.6 (A) / 9.6 (B)
Slewing Angle	°	400
Slewing Torque	mt	0.9
Stabilizer Spread	mm	4870 (R2 / R2X)
Fitting Space Required (std.)	mm	660
Width Folded	mm	2295
Operating Pressure	bar	315
Recommended Pump Capacity	l/min	25 - 35
Dead Weight (std.)	kg	920



- Equipped with load holding valves for safe crane operations
- High speed boom extension and retraction with Return Oil Utilization
- Optimized lifting performance with the use of high tensile steel and hexagonal boom design
- Lightweight yet robust construction according to European standards (EN 12999)
- Optional Overload Protection System and Emergency Stop Button
- Professional installation solutions with the use of Palsoft programme
- Suitable for installation on 2-axles trucks
- High Density (HD) Paint system provides better resale value retention and attractive aesthetics.

LIFETIME EXCELLENCE

PALFINGER LOADER CRANES ARE CONVINCING DUE TO THEIR SUPERIOR LIFE-CYCLE PERFORMANCE. THEY ARE THE MOST ECONOMICAL AND ALSO THE MOST RELIABLE OVER THE ENTIRE PRODUCT LIFE. FROM SOLUTION FINDING TO RE-SALE.

BETTER
SOLUTIONS

BETTER
EFFICIENCY

BETTER
ERGONOMICS

HIGHER VALUE
RETENTION



HIGHER
AVAILABILITY

HIGHER
SERVICEABILITY

BETTER
ECOLOGY

MORE
RELIABILITY

For further information please visit: www.palfinger.com/thebrand

PALFINGER ASIA PACIFIC PTE LTD

3 INTERNATIONAL BUSINESS PARK | NORDIC EUROPEAN CENTRE
05-25/26 | 609927 | SINGAPORE
T +65 6591 9191 | F +65 6591 7737
Enquiries: asia@palfinger.com
Website: www.palfinger.com

