

SPK 38502

PALFINGER

LIFETIME EXCELLENCE

**PALFINGER ASIA PACIFIC
KNUCKLE BOOM CRANES**



SPK 38502

SPK 38502 B

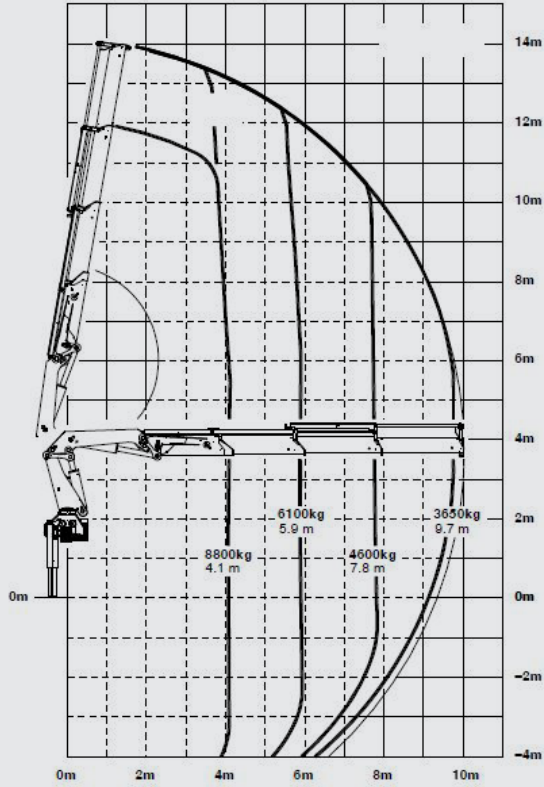

SPK 38502 C

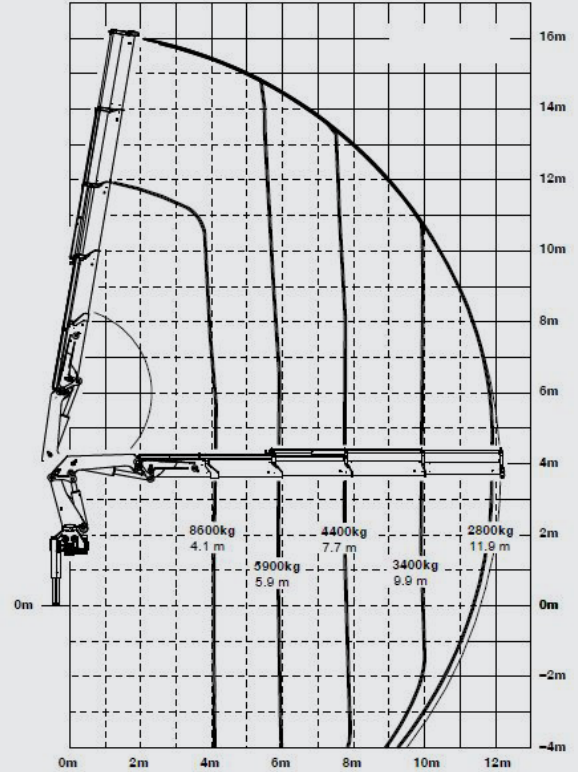

DIMENSIONS

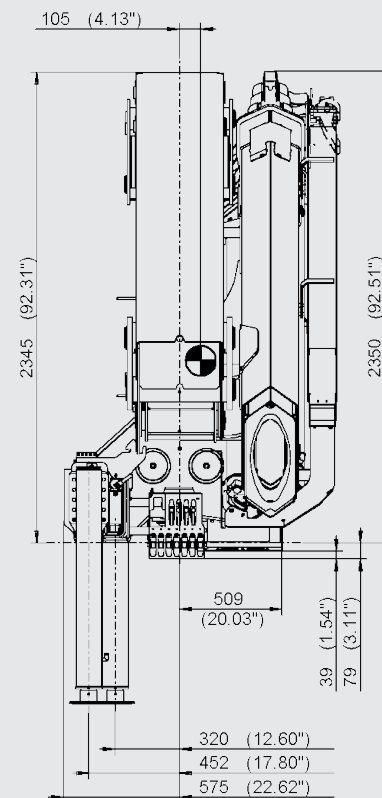
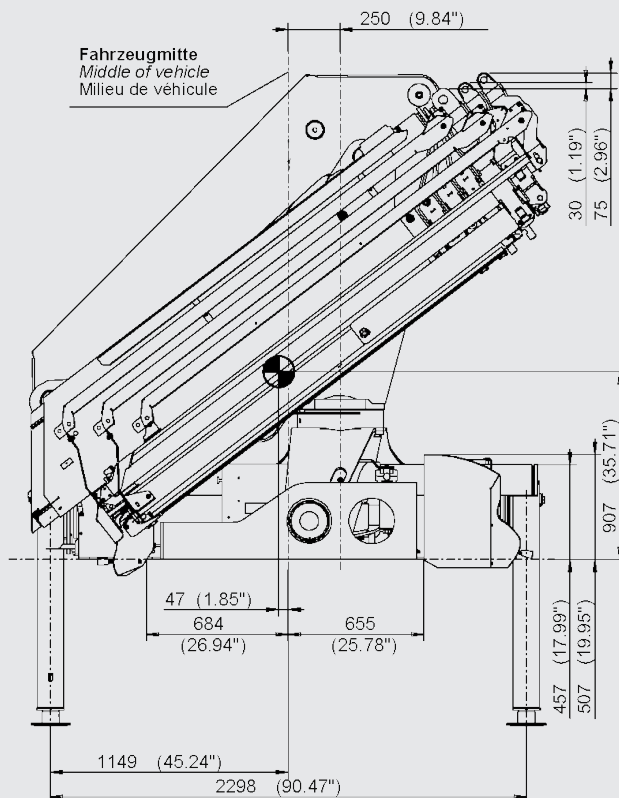

All dimensions are in mm

SPK 38502 D

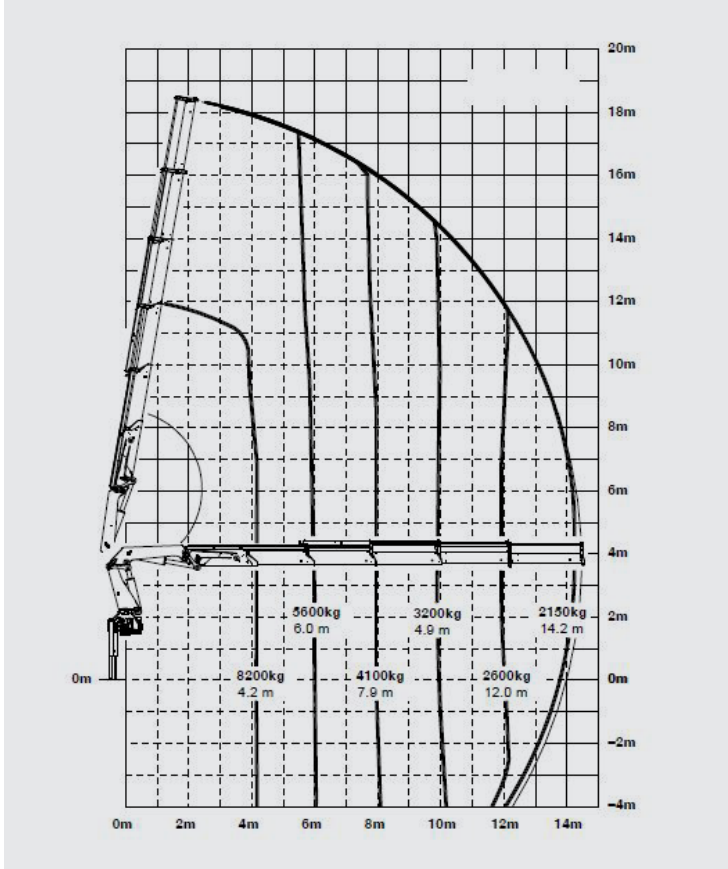

SPK 38502 E

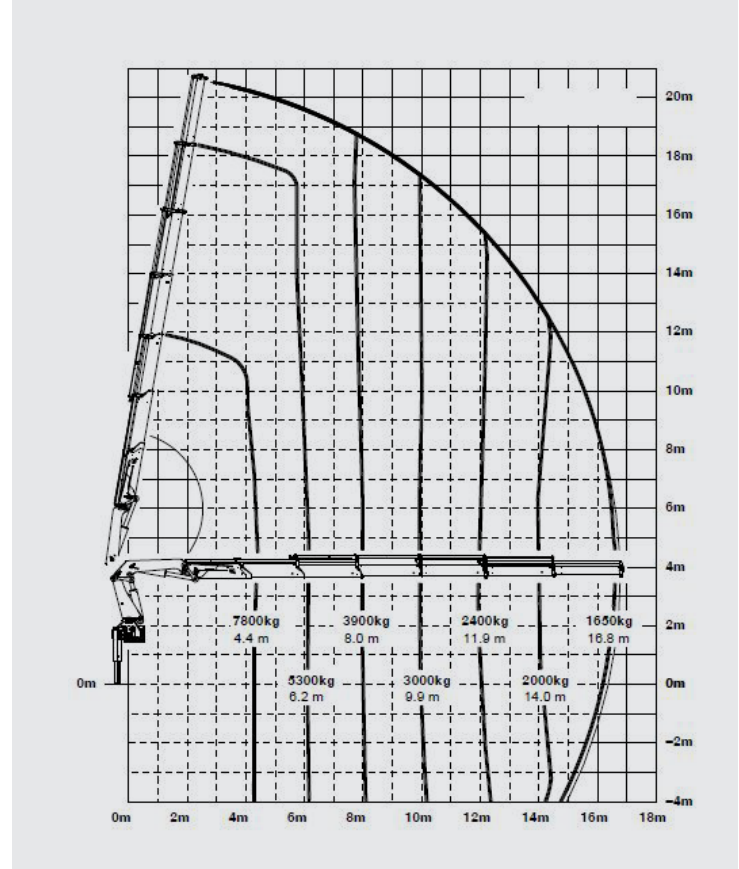

TECHNICAL SPECIFICATIONS (EN 12999 H1-B3)

- Equipped with load holding valves for safe crane operations
- High speed boom extension and retraction with Return Oil Utilization
- Optimized lifting performance with the use of high tensile steel and hexagonal boom design
- Lightweight yet robust construction according to European standards (EN 12999)
- Optional Overload Protection System and Emergency Stop Button
- Professional installation solutions with the use of Palsoft programme
- Suitable for installation on 4-axles trucks
- High Density (HD) Paint system provides better resale value retention and attractive aesthetics.

Max. Lifting Moment	mt	38.2
Max. Lifting Capacity	kg	13000
Max. Hydraulic Outreach	m	10.0 (B) / 12.1 (C) / 14.5 (D) / 16.8 (E)
Slewing Angle	o	400
Slewing Torque	mt	5.0
Stabilizer Spread	mm	6600 (R3X)
Fitting Space Required (Std)	mm	1210
Width Folded	mm	2500
Operating Pressure	bar	300
Recommended Pump Capacity	l/min	55 - 80
Dead Weight (Std)	kg	4205



LIFETIME EXCELLENCE

PALFINGER LOADER CRANES ARE CONVINCING DUE TO THEIR SUPERIOR LIFE-CYCLE PERFORMANCE. THEY ARE THE MOST ECONOMICAL AND ALSO THE MOST RELIABLE OVER THE ENTIRE PRODUCT LIFE. FROM SOLUTION FINDING TO RE-SALE.

BETTER
SOLUTIONS

BETTER
EFFICIENCY

BETTER
ERGONOMICS

HIGHER VALUE
RETENTION



HIGHER
AVAILABILITY

HIGHER
SERVICEABILITY

BETTER
ECOLOGY

MORE
RELIABILITY

For further information please visit: www.palfinger.com/thebrand

PALFINGER ASIA PACIFIC PTE LTD

3 INTERNATIONAL BUSINESS PARK | NORDIC EUROPEAN CENTRE
05-25/26 | 609927 | SINGAPORE
T +65 6591 9191 | F +65 6591 7737
Enquiries: asia@palfinger.com
Website: www.palfinger.com

