

# SPK 36080 KNUCKLE BOOM CRANE

IDEAL LIFTING SOLUTION FOR 3 AXLE TRUCKS



# TECHNICAL SPECIFICATIONS

## Product Description

- Lightweight yet robust construction according to European standards (EN 12999)
- Electronic Overload Protection (Paltronic 50) and Emergency stop button
- High speed boom extension and retraction with Return Oil Utilization
- Optimised lifting performance with the use of high tensile steel and hexagonal boom design
- Standard package includes
  - Emergency stop button
  - Working light
  - High pressure filter
  - Over-winding stop
  - Piston pump for reliability, efficiency, and extended lifetime

## Technical Data

Basic Data	SPK 36080B	SPK 36080C	SPK 36080D
Max. lifting Moment	34.2 mt	33.6 mt	33.0 mt
Max. lifting capacity	8300 kg	8100 kg	6700 kg
Max. outreach	10.1 m	12.1 m	14.2 m
Slewing angle	400°	400°	400°
Slewing torque	3.8 mt	3.8 mt	3.8 mt
Stabilizer spread	6.0 (R3X)	6.0 (R3X)	6.0 (R3X)
Fitting space required (Std)	0.975 m	0.975 m	0.975 m
Width Folded	2.5 m	2.5 m	2.5 m
Operating pressure	330 bar	330 bar	330 bar
Recommended pump capacity	55 - 80 L/min	55 - 80 L/min	55 - 80 L/min
Dead Weight (Std)	3323 kg	3513 kg	3673kg

# LIFTING CHART

SPK 36080B

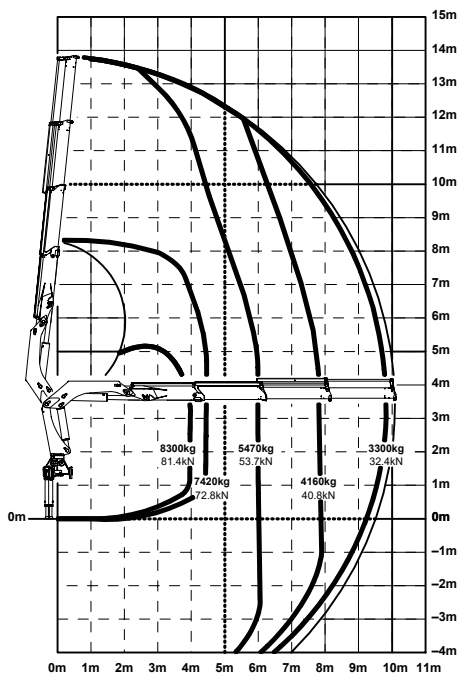

SPK 36080C

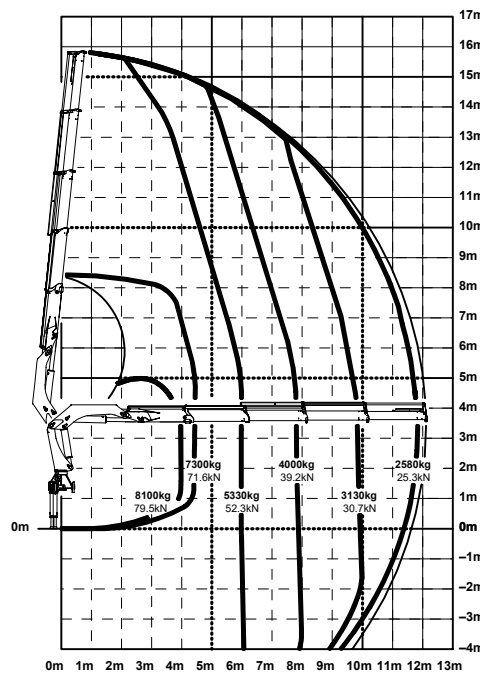

SPK 36080D

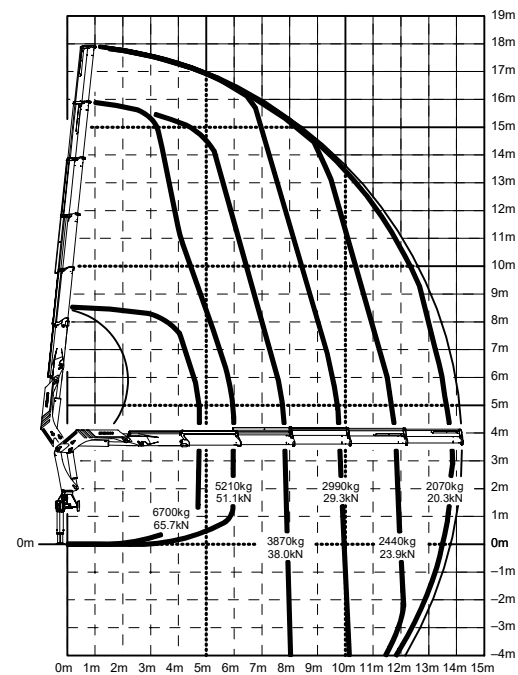

### NOTE

The above lifting height and boom angles are based on a straight (unladen) boom. Allowance should be made for boom deflection under laden conditions. Lifting capacities must not exceed 85% of tipping load.

# CRANE DIMENSION

SPK 36080B-F/L

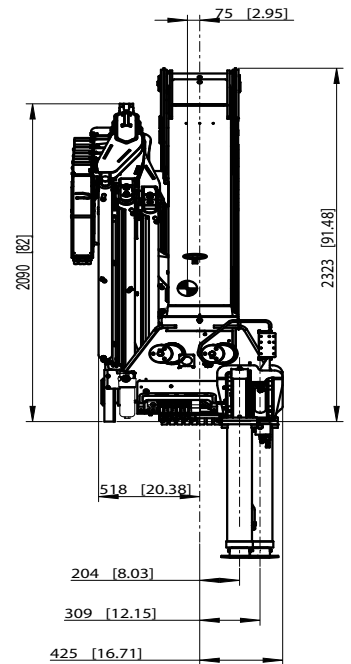
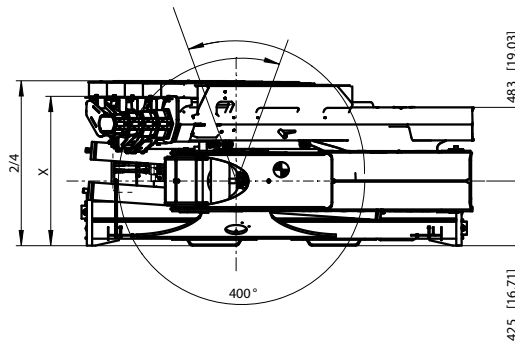
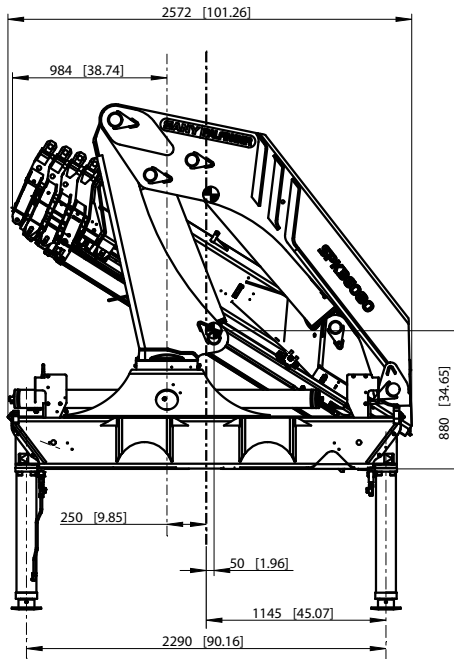

\*The actual product dimensions can vary depending on the operational equipment.

# FEATURES & OPTIONS



## Ergonomic Crane Control

- Ergonomically arranged operating levers for all crane functions
- Functional design for better comfort during crane operation
- Straightforward service and maintenance



## Oil Cooler

- Longer service life of the oil, seals, valves, and other hydraulic components through lower oil temperature



## Load Holding Valve

- Holds the cylinder in position
- Standard fittings on all cylinder
- Strategic positioned to protect from damage



## High speed extension

- Increase extension and retraction speed of the boom system
- Crane works faster with return oil utilization
- Time saving during crane operation



## Radio Remote Control

- Efficient control of the crane remotely
- Safe crane operation outside of the danger zone
- Easy maintenance and quick troubleshooting



## Top Seat

- Excellent visibility of the surrounding area
- Foldable sun protection umbrella for hot weather
- Seat cover to prevent exposure from sun



## Hydraulic Overload Safety Device

- Prevents the crane from overloading
- Overload protection system with emergency cut-off function
- Stops all movements of the crane that increases load



## Hose Equipment for Attachments

- Additional hydraulic functions for attachments
- Simple installation with hose tray protection
- Diverse applications suitable for different industry

