

OIL AND GAS SEGMENT

STATE-OF-THE-ART OIL AND GAS SOLUTIONS



CELEBRATING THE FUTURE SINCE 1932

We have always had an eye on innovations.

Our pioneering spirit has driven us to constantly grow and evolve – from a small workshop to a crane manufacturer and ultimately to the leading provider of innovative lifting solutions. We have pushed the boundaries for generations, have successfully reinvented ourselves and set standards worldwide. In other words: We have been celebrating the future since 1932.

LIFTING VALUE – CREATING MOMENTUM

This is our vision. It defines what PALFINGER aims to be in the future and is the very essence of why we do what we do now.

PALFINGER MARINE lives by this vision every day, too. The company is an integral part of PALFINGER, with around 12,770 employees, with more than 30 production and assembly locations, and a global network of 5,000 service points. In 90+ years of success, PALFINGER has positioned itself as a market leader in lifting solutions and has introduced numerous state-of-the-art products along the way. Eventually, PALFINGER entered new markets and took root offshore. Today, we provide cutting-edge solutions for the maritime and offshore industry. With PALFINGER MARINE's valuable contribution and stable growth, PALFINGER achieved an overall revenue of EUR 2.45 billion in 2023.

And our journey continues!





PALFINGER STRATEGY 2030

The PALFINGER Strategy 2030 is the route for our vision to become a reality. It is based on two strategic pillars: “Go for Solutions” and “Go Digital”.

○ GO FOR SOLUTIONS

By 2030, we will be a solution provider that equips our customers with complete solutions, combining physical and digital elements into one unit – thus creating smart and highly networked machines. Step by step, PALFINGER will evolve from a product provider to a solution provider.

For PALFINGER MARINE, “Go for Solutions” means offering our customers complete, integrated marine solutions across all maritime segments.

○ GO DIGITAL

PALFINGER is continuously digitalizing the entire production and value-added chain. The main goal at the end of the day is to be able to offer customers smart lifting solutions and services that provide increased functionality and added value. In line with this strategic pillar, our integrated marine solutions will be enhanced with assisted, remote, and autonomous control functions for marine applications.

*Together we
are shaping
the future of
our customers’
lifting
solutions –
PALFINGER.*



SOLUTIONS FOR OIL AND GAS APPLICATIONS

PALFINGER supplies equipment for all types of fixed and floating installations related to the extraction of oil and gas at sea. All equipment is delivered according to requirements from class societies, national and international regulations, and standards like NORSOK, SOLAS, USCG, ISO EN 13852, API 2C, IEC Ex, the ATEX directive, and NEC in addition to customers' own company standards. If third-party certification is needed, PALFINGER takes care of the total process of calculations, verification, testing and documentation.

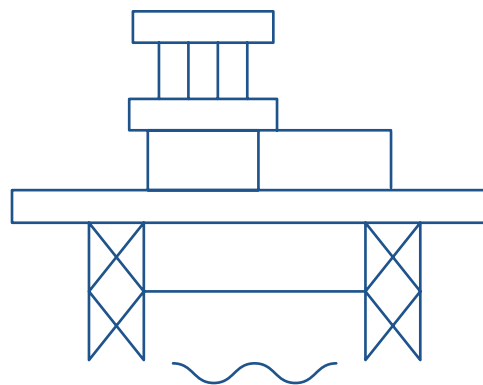

REFERENCE PROJECTS

- Gina Krogh, Equinor
- Ivar Aasen, Aker BP
- Johan Castberg FPSO, Equinor
- Johan Sverdrup, Equinor
- Martin Linge, Equinor
- Yggdrasil (former NOAKA), Aker BP
- Modec FPSO's, MV29/30/32/33
- Valhall, Aker BP
- Petronas PFLNG, Satu & Dua
- Yinson FPSO, Anna Nery
- Modec FPSO, Bacalhau
- Modec FPSO, Léopold Sédar Sengho (Sangomar field)

TYPICAL APPLICATIONS

- Fixed platforms
- Semi-submersible rigs
- Drill ships
- Jack-ups
- Floating production storage and offloading unit (FPSO)



IDEAL FOR OFFSHORE OPERATIONS IN HEAVY SEAS

STIFF BOOM CRANES

PALFINGER's stiff boom cranes are based on a pedestal slewing design with hydraulic cylinder luffing. The cranes are available with lifting moments in the range from 141 to 30,000 kNm and are supplied according to customer requirements. The stiff boom cranes can be delivered within a broad range of certifications and numerous optional features. In the oil and gas industry, stiff boom cranes are typically used on fixed installations.

FEATURES

- Hoisting capacity up to 100 metric tons
- Jib radius up to 50 meters
- Long-life surface treatment: corrosion protection
- Operation from control platform on crane
- Electro hydraulic drive
- Continuous slewing
- Low/high-temperature operations
- Anti-collision system

OPTIONS

- Constant tensioning
- Remote control / operator's cabin
- Overload protection: MOPS, AOPS
- Lifting of personnel – man-riding
- External hydraulic power packs
- Active Heave Compensation (AHC)
- ATEX Zone 1 and 2 execution
- Tugger winches





TELESCOPIC BOOM CRANES

PALFINGER's telescopic boom cranes are based on a pedestal slewing design with hydraulic cylinder luffing. The boom extension is a telescopic inner section that enables a more flexible and wider operational radius and leaves the crane stored in a compact position.

Their low weight and less complex design make them particularly maintenance-friendly. They are available with lifting moments from 140 to 12,000 kNm and are supplied according to customer requirements with numerous optional features.

FEATURES

- Hoisting capacity up to 50 metric tons
- Jib radius up to 40 meters
- Long-life surface treatment: corrosion protection
- Operation from control platform on crane
- Electro hydraulic drive
- Continuous slewing
- Low/high-temperature operations
- Anti-collision system

OPTIONS

- Constant tensioning
- Remote control / operator's cabin
- Overload protection: MOPS, AOPS
- Lifting of personnel – man-riding
- External hydraulic power packs
- Active Heave Compensation (AHC)
- ATEX Zone 1 and 2 execution
- Tugger winches

HIGHLY FLEXIBLE AND IMMENSELY STRONG

KNUCKLE BOOM CRANES

PALFINGER's knuckle boom cranes are designed to lift high loads with the jib extended and to provide the operator with great flexibility during lifting operations. Among other functions, they are used for pipe and boat handling. The knuckle boom crane range is available with lifting moments from 130 to 30,000 kNm. Severe weather conditions and heavy seas introduce oscillating motions to suspend loads. The improved level of control makes the crane ideal for offshore lifting operations in higher sea states.

FEATURES

- Hoisting capacity up to 100 metric tons
- Jib radius up to 50 meters
- Long-life surface treatment: corrosion protection
- Operation from control platform on crane
- Electro hydraulic drive
- Continuous slewing
- Low/high-temperature operations
- Anti-collision system

OPTIONS

- Constant tensioning
- Remote control / operator's cabin
- Overload protection: MOPS, AOPS
- Lifting of personnel – man-riding
- External hydraulic power packs
- Active Heave Compensation (AHC)
- ATEX Zone 1 and 2 execution
- Tugger winches





FOLDABLE KNUCKLE BOOM CRANES

Their sophisticated crane geometry and compact construction make PALFINGER MARINE foldable knuckle boom cranes a convenient, multi-functional tool for effortless loading and unloading of equipment – especially in confined working areas. They can be customized to meet offshore rules and regulations and come with a variety of options and additional features.

FEATURES

- Lifting capacity up to 32 metric tons
- Outreach up to 22 meters
- Surface treatment / corrosion protection according to offshore standards
- Rack & pinion single and double slewing cylinders as well as continuous slewing system
- Power link system

OPTIONS

- Constant tension winches
- Radio and cable remote control
- Standing operator platform
- Operator cabin
- Overload protection: MOPS, AOPS
- Lifting of personnel – man-riding
- Workman basket
- Mounting pedestal integrated and external hydraulic power pack
- ATEX Zone 1 and 2 execution
- Central greasing system
- Special skid base for temporary installations
- Design according NORSOK / DNV-ST-0378

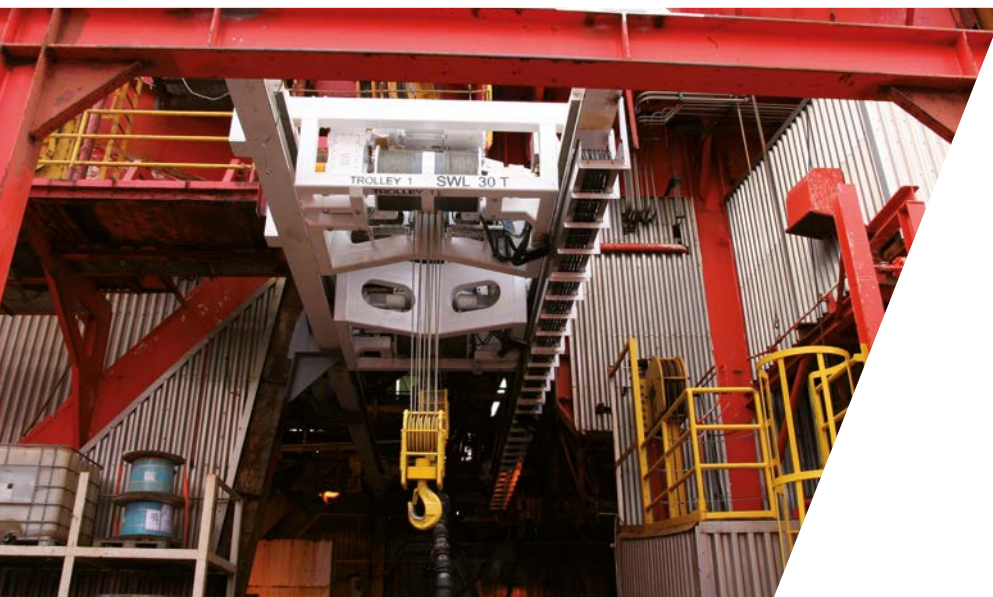

TRAVELLING CRANES

PALFINGER MARINE travelling cranes come in a variety of configurations and serve a wide range of applications. They can travel within a given area of operation and can be designed as overhead, under-slung, gantry, or semi-gantry structures. Depending on the project, travelling cranes are available with electric or hydraulic drives and custom-built for specific requirements.

FEATURES

- Hoisting capacity up to 600 metric tons
- Long-life surface treatment: corrosion protection
- Operation from control platform on crane
- Electro hydraulic drive or fully electric
- Low/high-temperature operations

OPTIONS

- Remote control
- Offshore Control System (OCS)
- External hydraulic power packs
- Anti-collision system



FULLY ELECTRIC TRAVELLING JIB CRANES

One of the most important features of PALFINGER MARINE's wallmounted travelling cranes is their ability to move along the side of a structure or a wall. This unique capability allows them to work in areas that are difficult to access with traditional cranes. Wallmounted travelling cranes typically consist of a main crane unit that is mounted on a rail system, which allows it to move along the side of a structure. They can be used for a wide range of tasks, including lifting and positioning heavy equipment, installing and maintaining pipelines and cables, and performing maintenance and repairs on offshore structures. Another advantage they can quickly and easily position themselves to perform tasks, which can save time and reduce costs compared to traditional cranes.

These cranes can also be designed for high risk operation with redundant hoisting system making it possible to work close to live wells.

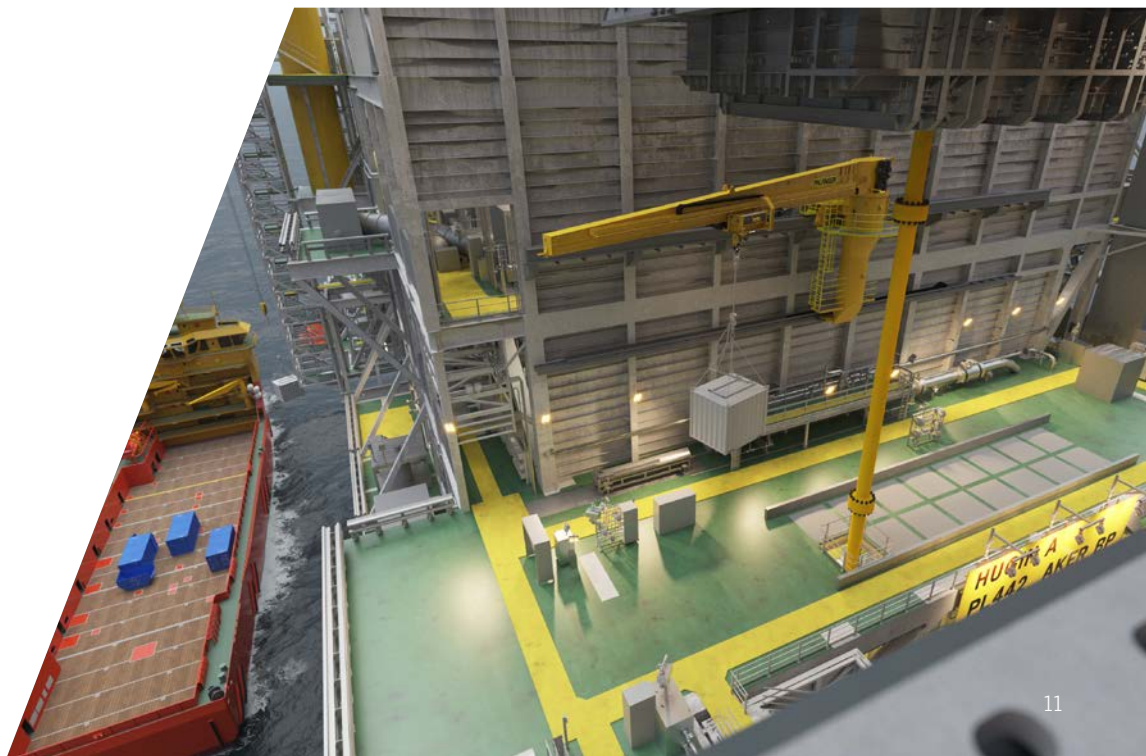

WIRE LUFFING LATTICE BOOM CRANES

PALFINGER MARINE wire luffing lattice boom cranes are based on a slewing pedestal design. The cranes are state-of-the-art and supplied according to the latest offshore rules and regulations. They are supplied with built-in electro-hydraulic or diesel hydraulic power packs.

FEATURES

- Hoisting capacity up to 100 metric tons
- Jib radius up to 70 meters
- Internal slewing gearing and slewing gears
- Reduced need for maintenance
- Electro hydraulic or diesel hydraulic drive
- Easy access to all types of maintenance
- Weight optimized
- Enables operation with a significant wave height up to 6 m
- Operator's cabin
- Anti-collision system

OPTIONS

- Tugger winches
- Remote control
- Design according to API-2C / ABS / EN13852
NORSOK / DNV-ST-0378
- AOPS / MOPS / Tensioning
- Personnel lift
- Metalizing
- ATEX Zone 1 and 2 execution





FULLY ELECTRIC WIRE LUFFING LATTICE BOOM CRANES

PALFINGER MARINE has developed a new and innovative range of wire luffing lattice boom cranes with fully electric drive based on VFD technology, designed according to EN13852-1 and NORSOK R002. The cranes offer high quality alongside optimized weight and need no oil and less power, making them remarkably environmentally friendly. In addition, reduced maintenance needs cut down on total lifetime costs.

FEATURES

- Hoisting capacity up to 100 metric tons
- Jib radius up to 70 meters
- State-of-the-art control system
- Safe to use up to a significant wave height up to 6 m
- Optimized load charts to ensure flexibility in operation
- Designed for easy maintenance
- Access to all areas of the crane
- Remote access to crane for quick support and fault detection
- Off-the-shelf components to ensure easy maintenance and quick supply of spare parts

ADVANTAGES

- Less vibration, less noise
- Less components
- Smoother and more predictable operations
- Reduction in maintenance costs
- Subject to wear and tear
- No risk of oil spill
- Less power consumption

MODULARIZED OFFSHORE CRANE SYSTEM

PALFINGER MARINE has developed a modularized wire luffing lattice boom crane system that allows the individual configuration – from cabin to luffing winch and more – of one of the most indispensable offshore lifting solutions. Alongside the advantage of being able to adapt to customer needs quickly, the scalable, modularized solution boasts many other benefits. A repeatable manufacturing and assembly platform results in a high-quality product which facilitates efficient maintenance.

MODULARIZATION OPTIONS

- Standard offshore cabin or high-performance cabin
- Electro hydraulic, diesel hydraulic, or fully hydraulic drive system
- Access for maintenance via stairs or ladders
- Main winch system vs. aux winch system
- Available for remote operation
- Min. length 36 m, max. length 60 m
- Luffing winch for standard luffing system or redundant luffing system with two winches

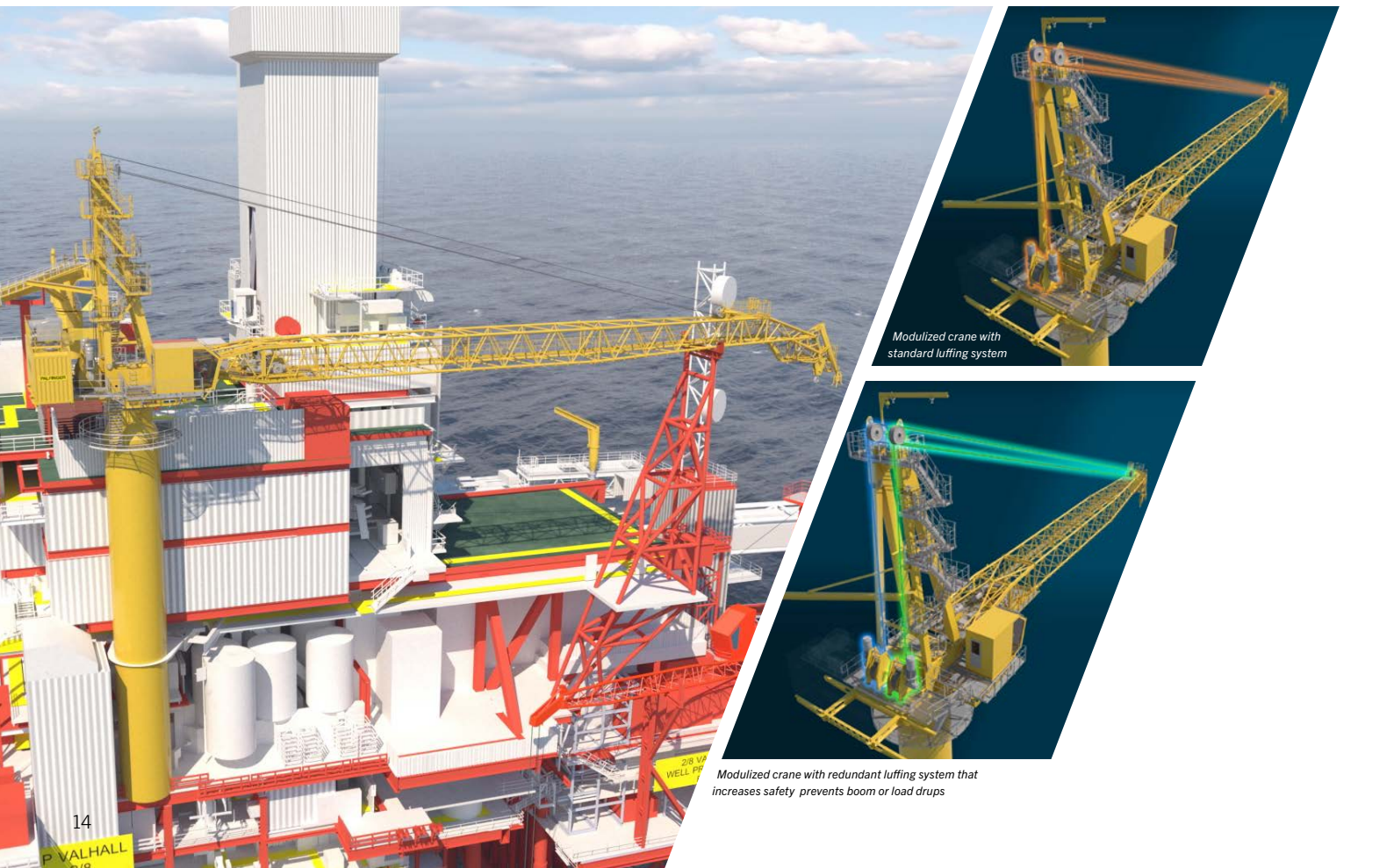

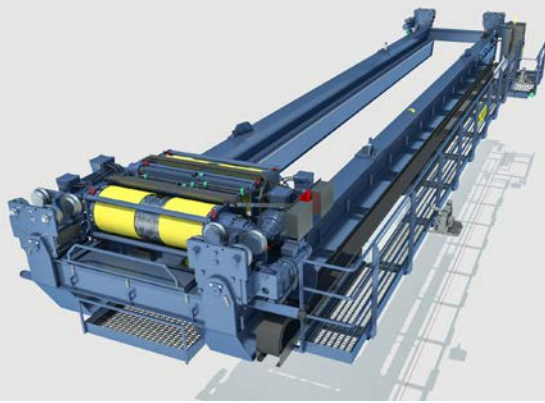
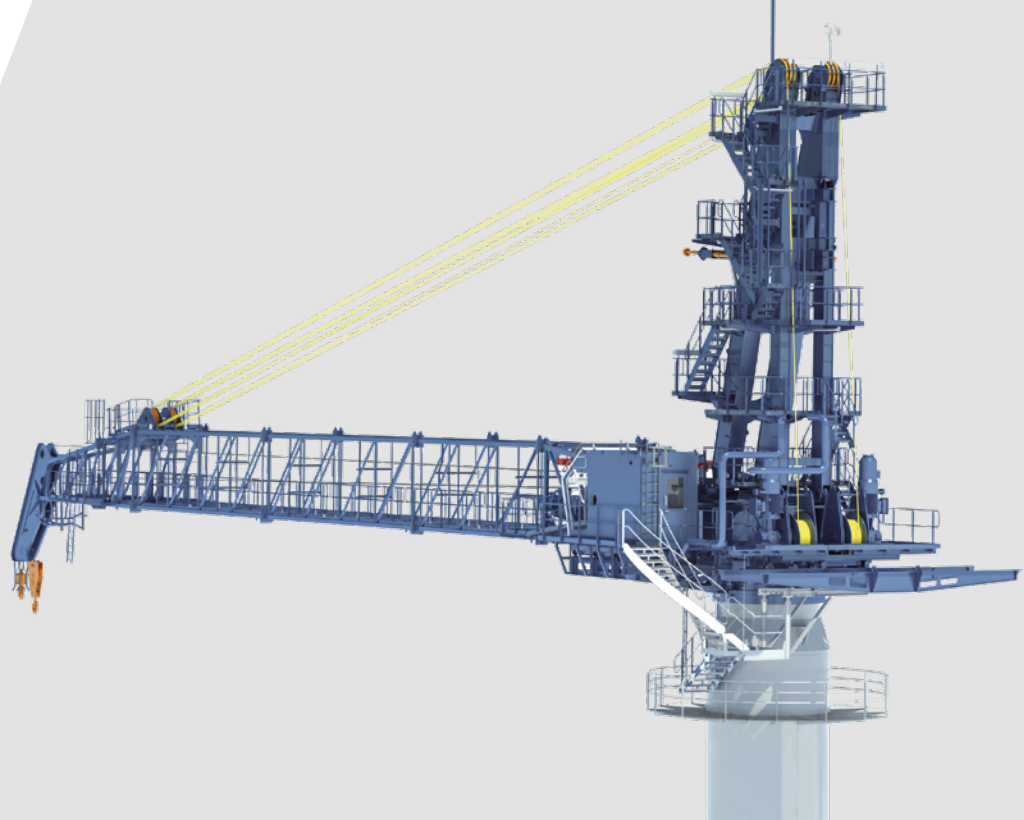

HIGH-RISK OPERATION FEATURES

PALFINGER MARINE's offshore cranes can be delivered with additional features for high-risk operations. These features are specially adapted to cranes that are used for various applications where the consequences of potential failures are high.

OFFSHORE PEDESTAL CRANES

One of the major risks is a boom fall. In this situation, it will be difficult to predict where the load and boom will come down. This risk can be minimized by using PALFINGER MARINE's double luffing system which ensures that a failure in one of the winches or wire rope will not lead to a boom fall or load drop even with full load in the worst conditions. The system is highly reliable without adding any components compared to a traditional luffing system.

TRAVELLING CRANES

PALFINGER MARINE can deliver 100 % redundant hoisting systems where any kind of failure to any of the components in the system including a wire failure will not cause any uncontrolled movement of the load. Due to their high level of performance, the cranes also prevent uncontrolled movements of the bridge or trolley motions.

FULLY ELECTRIC JIB CRANES FOR UNMANNED OFFSHORE INSTALLATIONS

PALFINGER JIB CRANES

PALFINGER MARINE has developed fully electric jib cranes for use on low-manned or unmanned offshore installations. Designed to withstand harsh environments, these cranes have no exposed components in the parked position. The control system can be fully integrated into and operated remotely from an onshore control location, with start-up procedures, diagnostics, and integrated support and logistic functions. Their power consumption is only 30 to 50 percent compared to conventional offshore cranes.

Benefits of the crane include zero accidents due to autonomous features and no personnel in the critical loading area, as well as zero waste of energy and time due to fully electric operations, immediate log-in on various platforms, and reduced helicopter transfers.



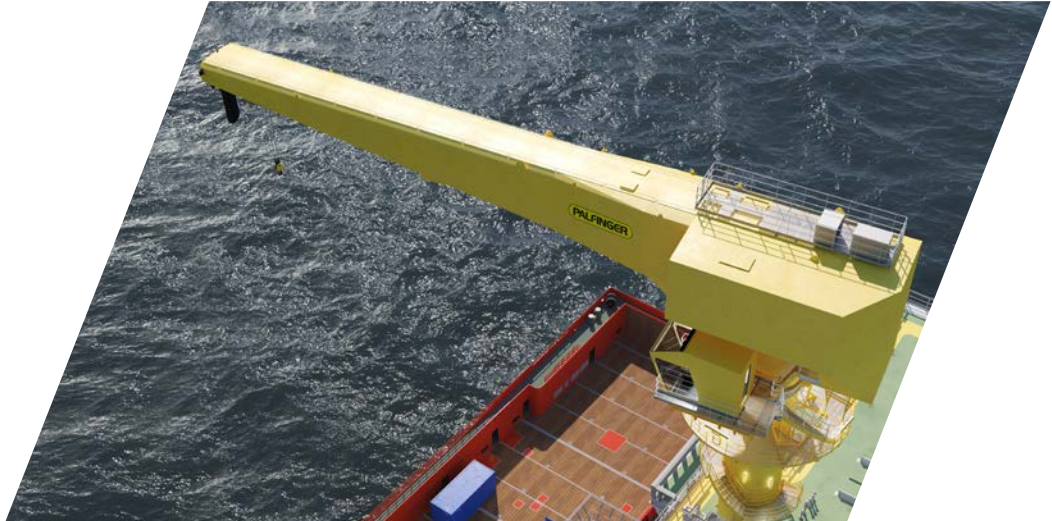
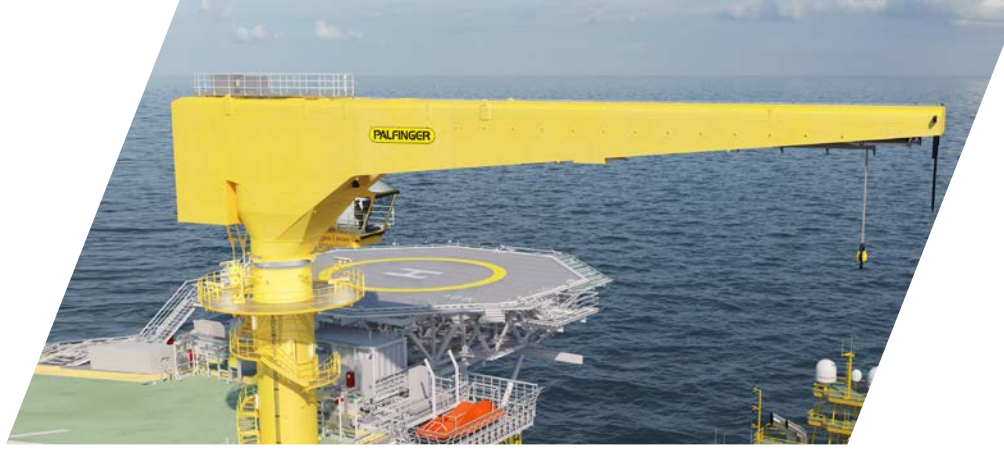

FEATURES

- All critical components are sheltered from weather conditions when crane is parked.
- HVAC system for climate control inside the crane
- Fully electric drive for all motions
- Crane can be fully operated from onshore control room – no need for people offshore
- Crane cabin for offshore operation available
- Battery room with enough energy stored to move the crane into safe position in case of power loss
- Energy efficient drive system with common DC bus and regeneration
- Significantly reduced energy consumption and CO2 emissions compared to traditional cranes
- Crane designed for high-risk operations and as personnel lift with high level of redundancy

OUTREACH	LIFTING CAPACITY
Typically 30–40 meter	Typically 30–70 tons



©Equinor

LIFEBOAT AND DAVIT SOLUTIONS FOR THE OIL AND GAS INDUSTRY

PALFINGER LIFEBOATS AND DAVITS

PALFINGER MARINE free-fall lifeboats and enclosed lifeboats are designed to meet the latest IMO/SOLAS regulations and are suitable for a variety of oil and gas applications include platforms of any type, drill ships, FPSOs, car carriers, any large complement ship and many more. PALFINGER MARINE also offers a wide range of lifeboat davits with multiple configurations, enabling customers to choose the most suitable davit system for their specific project requirements.

FREE-FALL LIFEBOATS

- Designed and approved according to DNV-ST-E406/ NORSOK R-002 & SOLAS standards
- Capacity for 70 people based on an average weight of 100 kg per person
- Free-fall height: 46 meters
- Superior space and comfort for people with an average size from 1.4 m to 2.1 m and weight from 50 kg to 150 kg
- Twin steering position
- Designed for free fall into waves – verification of project-specific weather data by CFD simulations
- Structural design for maximum strength and safety and minimum deflection

FREE-FALL DAVITS

- Compliance with IMO / SOLAS regulations
- Selected models designed according to NORSOK standard
- Free-fall launching or hydraulic lowering
- Safe working load from 50 kN to 313 kN

LIFEBOAT AND DAVIT SOLUTIONS FOR THE OIL AND GAS INDUSTRY

TOTALLY ENCLOSED LIFEBOATS

- Fully enclosed lifeboat series with a capacity of 21 to 150 passengers
- Various seat arrangements to meet specific project requirements
- Winterization or Polar-Code-compliant packages up to -40°C Polar Service Temperature (PST)
- Competitive pricing and lifeboat range for different segments
- Compliance with the latest SOLAS/LSA Code, MED as well as USCG and Transport Canada regulations

LIFEBOAT DAVITS

- Multiple lifeboat davit configurations (gravity, electro-hydraulic, fully hydraulic) suitable for all needs and project requirements
- N Series known for its innovative and fully enclosed design, with all major components mounted inside the davit structure and fully protected from the weather
- Winterization or Polar-Code-compliant packages up to -40°C Polar Service Temperature (PST)
- Available as either standard lifeboat davit (5 m/min) or life-/ rescue boat davit (18 m/min)
- Modular design with multiple configurations of standardized components for easy exchangeability and maintenance
- Compliance with the latest IMO/SOLAS regulations, LSA Code, MED as well as USCG and Transport Canada regulations





EXCELLENT MANEUVERABILITY AND STABILITY

(FAST) RESCUE BOATS AND DAVITS

PALFINGER MARINE fast rescue boats are known for their excellent maneuverability and stability, even in the toughest sea conditions. The fast rescue boats range covers the latest market developments and requirements, providing customers with models made from seawater-resistant aluminum (ALU) or glass-reinforced plastic (GRP). This makes them a strong, durable, and safe choice while reducing operational and maintenance costs. PALFINGER MARINE also offers a complete range of suitable fast rescue boat davits developed to meet the different market requirements for launching appliances. They are all designed in accordance with the latest IMO/SOLAS regulations and LSA Code.

(FAST) RESCUE BOAT DAVITS

- Multiple (electro-hydraulic and fully hydraulic) models to suit all decks and project requirements
- Delivered as a plug-and-play unit – pre-tested and fully certified
- Fully hydraulic series (PRH-H) designed for heavy-duty usage and multiple daily launching and recovery operations
- Innovative and fully enclosed davit system (N Series) incorporates all the main components inside the davit structure, protecting them from the weather
- N Series available with different configurations, including Standard (18 m/min) and High-Speed (48 m/min) versions with constant tensioning and shock-absorbing systems
- Winterization or Polar-Code-compliant packages up to –40°C Polar Service Temperature (PST)
- Fast rescue boat davit certificate available for High-Speed version on the NPDS 3500 FR (Ro-Ro certificate)

LIFE RAFT DAVITS

- Designed for lifeboats with up to 39 people
- Plug-and-play installation system
- Meet the latest SOLAS/LSA rules and regulations
- Different outreaches to suit various deck scenarios
- Fully certified CAR 35 Hook automatic release mechanism
- Quick return unit for launching multiple rafts

(FAST) RESCUE BOATS

- Models constructed out of either aluminum (ALU) or glass-reinforced plastic (GRP)
- Capacity of up to 15 people, including one on a stretcher
- Easy access to all the main components and service points
- Different inboard diesel engine configurations with water-jet propulsion
- Excellent maneuverability and stability due to V-shaped hull
- Compliance with the latest SOLAS, MED and USCG requirements as well as the LSA Code

FENDERS

- High-protection netting with aircraft tyres
- Complete STS mooring package – ropes, wires and hardware
- Fully compliant with ISO 17357:2014-1
- Chain and tyre net type / sling type





OUR SERVICE PORTFOLIO

As a leading manufacturer of innovative and reliable equipment for the oil and gas industry with an impressive global portfolio of 25+ brands, PALFINGER MARINE is committed to flexible and efficient service solutions. With a network of 27 sales and service hubs all over the world, we ensure fast and professional on-site support for our customers.





INSPECTION AND
MAINTENANCE

SPARE PARTS AND
REPAIR

REFURBISHMENT AND
UPGRADES



HOOK
REPLACEMENT

AGREEMENTS

TRAINING

INDUSTRIAL
SERVICES |
ROPE ACCESS

GLOBAL SERVICE NETWORK

PALFINGER MARINE is a reliable and professional partner in every situation, from telephone assistance to on-time delivery and instant on-site support. A global network of specially trained engineers and experts with extensive know-how and experience provides comprehensive, customized, and reliable service solutions to customers worldwide.





PALFINGER WORLDWIDE

📍 HQ SALZBURG, AUSTRIA
 📍 SALES AND SERVICE LOCATIONS
 🏭 ASSEMBLY AND PRODUCTION SITES

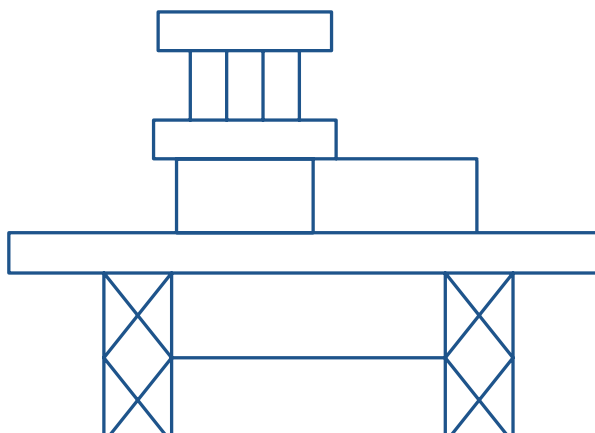

Palfinger Marine GmbH
F.-W.-Scherer-Strasse 24
5020 Salzburg | Austria

palfingermarine.com/contact

