

INTERLIFT

BY **PALFINGER**

INSTALLATION MANUAL & CHECK OFF SHEET

ILQ 22, 2200 lbs. Capacity

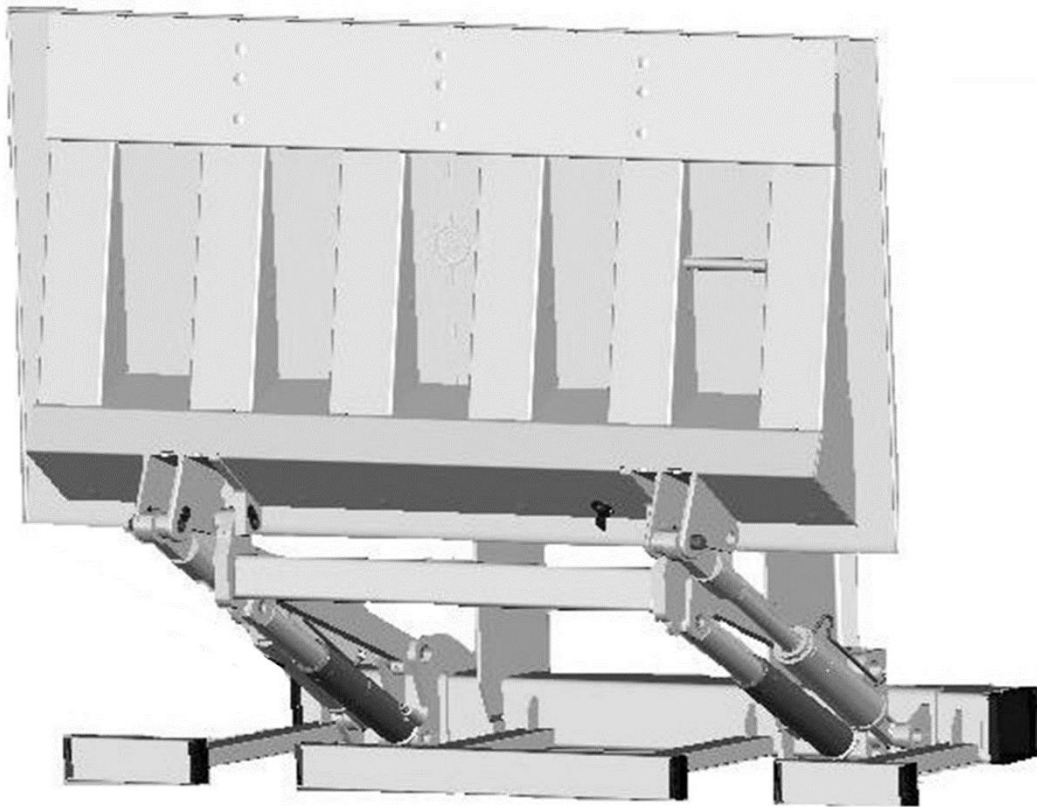

ILQ 22 Installation Manual
Document Part Number: 90-0613-200
ECN-M1723, Rev. 1.5, 01-19-24
Copyright © 2023 Palfinger Interlift, LLC.
All rights reserved.

Information in this document is subject to change without notice.
Visit www.palfinger.com for up to date information and notifications.

If you received this product with damaged or missing parts,
contact INTERLIFT Liftgates at (888)-774-5844

Parts Order/Inquiries
liftgateparts@palfinger.com

Technical Support
technicalapplications@palfinger.com



BY **PALFINGER**

15939 Piuma Ave.
Cerritos, CA 90703
Tel (888) 774-5844
Fax (562) 924-8318



BY **PALFINGER**

572 Whitehead Road.
Trenton, NJ 08619
Tel (609) 587-4200
Fax (609) 587-4201

TABLE OF CONTENTS

Manual Updates..... 4

Recommended Tools For Installation..... 5

1 Important Notes:..... 6

2 Dimension Sheet 8

 2.1 Installation Dimensions ILQ22..... 10

3 Chassis and Body Preparation for special applications..... 11

 3.1 Flip-Up door & Full-door seal kit installation 11

 3.2 Swing Door Applications 13

4 Liftgate and Platform Installation 14

 4.1 Sill Preparation 14

 4.2 Mount Plate Installation..... 14

 4.3 Installation with mounting fixture Sill Preparation 15

 4.4 Platform Installation 17

 4.4.1 Attach platform to liftarm..... 17

 4.4.2 Installation and Adjusting the tilt cylinders 17

 4.5 Installation without mount fixture 19

 4.6 Setting and Operation of B-16 Sensor..... 20

 4.7 Setting and Operation of B-13 Sensor..... 21

 4.8 Installation of left and right Up Stops..... 22

 4.9 Final Welding 23

5 Electrical Installation..... 24

 5.1 Main Power Connections 24

 5.2 On-off switch installation 26

 5.3 Remote Hand Control Installation 27

 5.4 Wiring Diagrams 29

 5.5 Connector Overview 30

 5.6 Hydraulic Schematic 31

6 Lubrication and Final Inspection..... 32

 6.1 Decal Placement and Inspection..... 33

7 Check Off Sheet..... 36

Company Information:

Company Name: _____

Advisor Name: _____

Vehicle Year Make & Model: _____

Liftgate Information:

Liftgate Serial Number: _____

Liftgate Model Number: _____

Date of Purchase: _____

Date of Installation: _____





Manual Updates

Revision	Description
v1.4	<ul style="list-style-type: none">• Added Section 4.2: Mount Plate Installation
v1.5	<ul style="list-style-type: none">• Changed logos, from Palfinger to Interlift

Recommended Tools For Installation

Metric Wrench Set	Basic Screwdrivers	Pliers	Wire Crimp Pliers
Test Light	Snap Ring Pliers	Hammer	Metric Allen Set 1.5mm-10mm
½" Impact & Sockets	Sm. Metric Socket Set	Assorted Drill Bits	Floor Jack or Equiv.
Sm. To Med. Bottle Jack	Forklift or O/H Crane	Hand Held Grinder	Paint Gun
Pry Bar	3/8 Drill Motor		Heat Gun or Equiv.
Min. 250 Amp Welder	Cutting Torch or Equiv.		

1 **Important Notes:**

1. **Read Manual completely before beginning any work**
2. Mount fixture must be ordered separately
3. Refer to your truck manufacture's instructions before adding any auxiliary equipment.
4. Pay Special attention to items marked with this symbol: 
5. All welding should be performed by qualified personnel per AWS standards
6. For flip up door or full seal kit applications, please read 3.1 first
7. For swing door applications, please read 3.2 first
8.  Always Ground closest to your welding point to prevent arcing through moving parts
9. Contact INTERLIFT Liftgates for Special Installations not covered in this Installation Manual
10.  Do not paint cylinder shafts or nylon rollers (Use non-chlorinated brake cleaner to remove over spray)
11. Verify that pin lock bolts are tight
12. Grease all pivot points
13. Verify that ALL decals are placed properly (Contact INTERLIFT Liftgates to replace any missing decals)
14.  Final Check-Off-Sheet at rear of this manual **MUST** be filled out and kept in your records for future reference.
15. Refer to owner's manual for troubleshooting & repairs.

Important Dimensions:

(Refer to line drawing on following pages)

- 1) BED HEIGHT [H] Bed Height Ranges: Max=Unloaded / Min=Loaded Truck
 - Measure from top of body floor to ground. Vehicle must be on flat level ground when measured.
- 2) MOUNT TUBE HEIGHT [F]
 - Measure from **TOP** of Mount Tube to **TOP** of body floor
- 3) MOUNT TUBE [K]
 - Measure from **rear of body** to forward edge of Mount Plate.
- 4) REAR SILL CUT OUT [S]
 - Refer to H, K & S Charts and Cut Out diagrams on following pages
- 5) GROUND CLEARANCE
 - Measure from **BOTTOM** of Mount Tube to ground

Mounting Notes:

Read and clearly understand manual **BEFORE** beginning ANY work



Important!!!



The basic rule of INTERLIFT Liftgates' ILQ installation is to raise mount frame to achieve **MAXIMUM** ground clearance **WITHOUT** exceeding Min "F" dimension.

Refer to mounting tables and determine the proper [S] dimension. If the sill is greater than what's allowed, the sill has to be notched and capped to achieve original strength. Bend flat stock and weld 100% around the notch.



Warning

- Minimum bed height dimensions are **ALWAYS MAXIMUM LOADED TRUCK**
- Floor Height Ranges: Max=Unloaded Truck; Min=Loaded

Installing a gate at or close to minimum bed height normally results in a gate that **will NOT open and close** from stored position **if the minimum floor height is exceeded when truck is loaded.**

Call tech support before starting the installation if you have any questions or concerns on mounting dimensions → 888-774-5844

2 Dimension Sheet



Trailer Chassis Dimension Sheet

Customer Information

Quote#/SO#: _____
 Company: _____
 Phone: _____
 Email: _____ @ _____

Liftgates Information:

Model: _____
 Capacity: _____
 Platform Size: _____
 Platform Material: _____

Trailer Information

Trailer Specifications:	
Manufacturer: (ex. Utility)	
GVWR: (ex. 68,000 lbs)	
Length: (ex. 53ft)	
Width: (96", 102")	

Type of Body (check applicable) <input checked="" type="checkbox"/>	
Van	<input type="checkbox"/>
Flatbed	<input type="checkbox"/>
Reefer	<input type="checkbox"/>
Other (specify) _____	<input type="checkbox"/>

Type of Rear Door (check applicable) <input checked="" type="checkbox"/>	
Flip-Up	<input type="checkbox"/>
Roll-Up	<input type="checkbox"/>
Swing	<input type="checkbox"/>
Other (specify) _____	<input type="checkbox"/>

Trailer Dimensions

A = Bedheight: Top of trailer floor to level ground (with airbags up):.....

B = Top of floor to bottom of trailer cross member:.....

C = Rear sill height (Top of floor to bottom of buck plate): *If Stepped sill complete M,N; If Tapered sill complete O, P.*

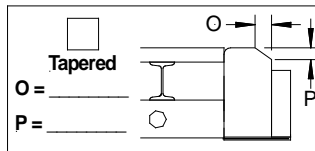
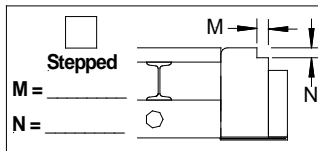
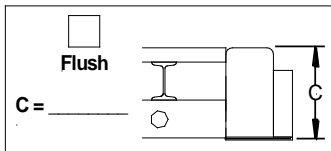

D = Crossmember height:.....

E = Tire to end of vehicle body:.....

F = Bogie to end of vehicle body:..... Sliding Suspension? Yes _____ No _____
 If Yes complete G, H, I, K, and L dimensions

G = Inside horizontal width of sliding suspension angles:.....

H = Diameter of sliding suspension holes:.....

I = Hole spacing:.....

J = Bottom of crossmembers to bottom of sliding ramp box, if applicable:.....

K = Rear sill face to first slider hole:.....

L = Top of floor, where liftgate platform will meet floor, to the center of the trailer slider holes:.....

X = Eyebrow depth:.....

Z = Top of floor, where the liftgate platform will meet the top of the eyebrow:.....

Notes:

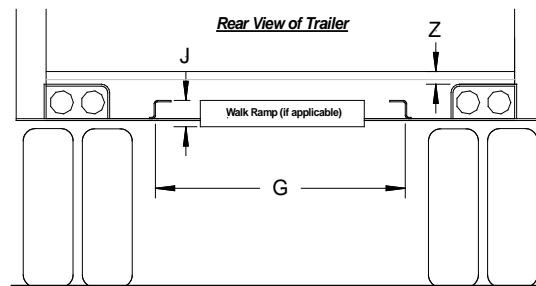
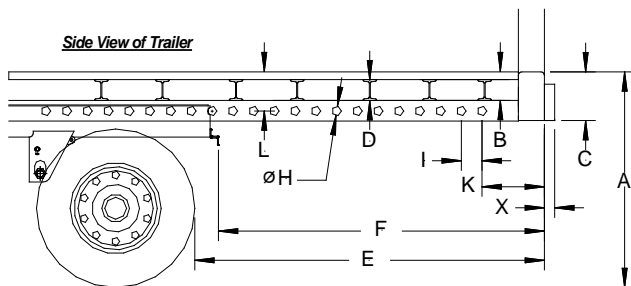

90-9813-002_b



Truck Chassis Dimension Sheet

Customer Information

Quote#/SO#: _____
 Company: _____
 Phone: _____
 Email: _____ @ _____

Liftgates Information:
Model
Capacity
Platform Size
Platform Material

Truck Information

Truck Specifications:
Manufacturer: (ex. Hino)
GVWR: (ex. 68,000 lbs)
Length: (ex. 53ft)
Width: (96", 102")

Type of Body (check applicable) <input checked="" type="checkbox"/>
Van
Flatbed
Reefer
Other (specify) _____

Type of Rear Door (check applicable) <input checked="" type="checkbox"/>
Flip-Up
Roll-Up
Swing
Other (specify) _____

Truck Dimensions

- A = Bedheight:..... Loaded Bedheight:.....
- B = Top of floor to bottom of frame:.....
- C = Rear sill height:.....
- D = Spring hanger to end of body (if applicable):.....
- E = Air bag suspension to end of body (if applicable):.....
- F = Tire to end of vehicle body:.....
- G = Gas tank to end of body (if applicable):.....
- H = Fuel filler hole to end of body (if applicable):.....
- I = Bottom of frame to bottom of gas tank (if applicable):.....
- J = Top of floor to bottom of sliding walk ramp (if applicable):.....
- K = Frame Width: Width of chassis frame:.....
- L = Frame Height: Height of chassis frame:.....

Notes:

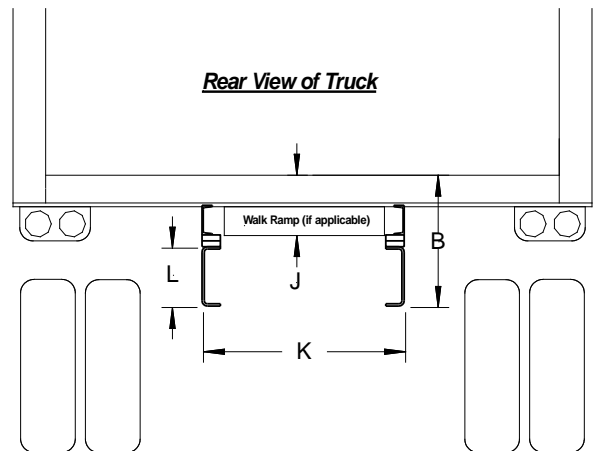
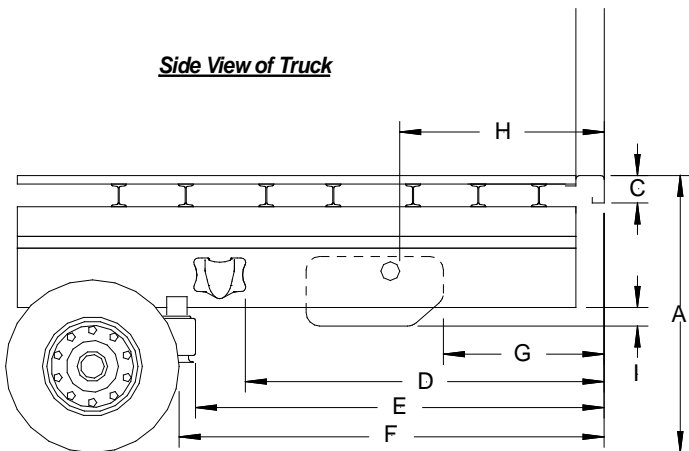

90-9813-003_b

2.1 Installation Dimensions **ILQ22**

IMPORTANT:

Always use the **smallest F-dim possible** for best ground clearance (don't exceed max. ground clearance!)

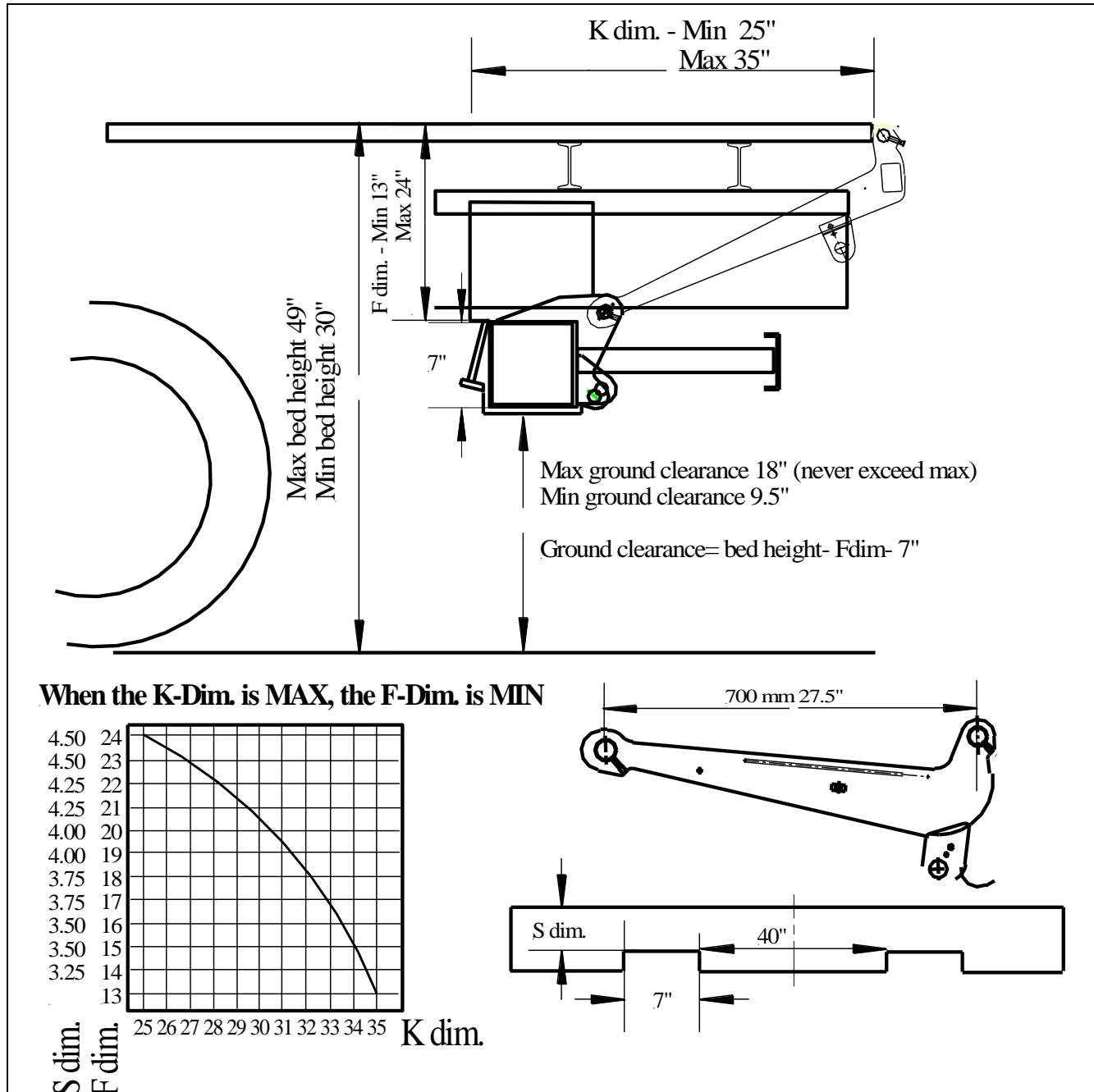

Figure 1 ILQ22 mounting dimensions

Part number for ILQ 22 Mounting Fixture: 1-00015



MINIMUM bed height is defined as truck/trailer loaded to MAX GVW

3 Chassis and Body Preparation for special applications

3.1 Flip-Up door & Full-door seal kit installation

1. Install 1/2" x 1-1/2" HR flat bar to the lower rear body seal

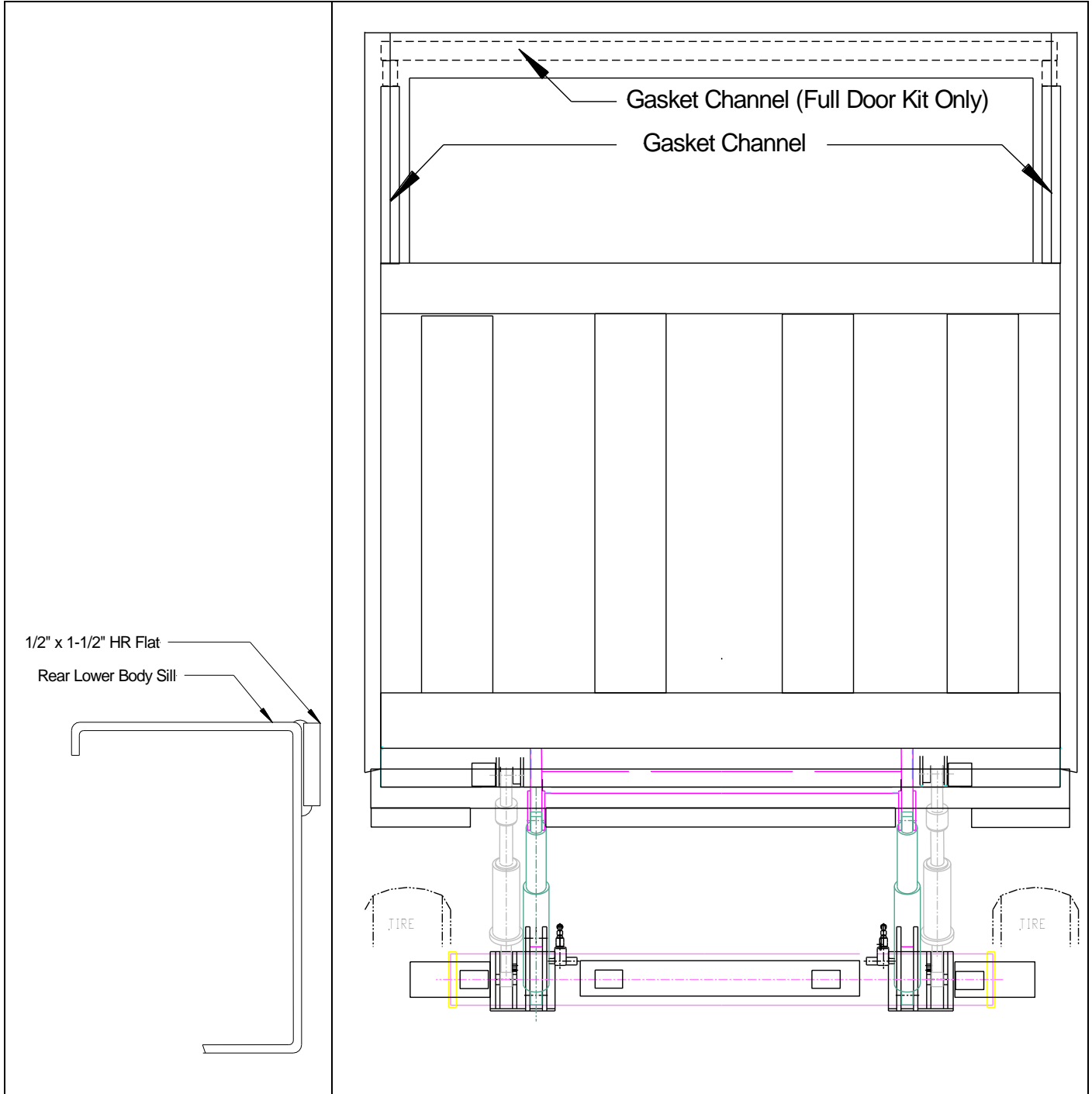

Figure 2 Full door seal kit

2. Install gate per instructions per 4.1
3. Install gasket channels on rear vertical body posts to match width of platform
4. For full door seal kits install gasket channel along header at edge of platform

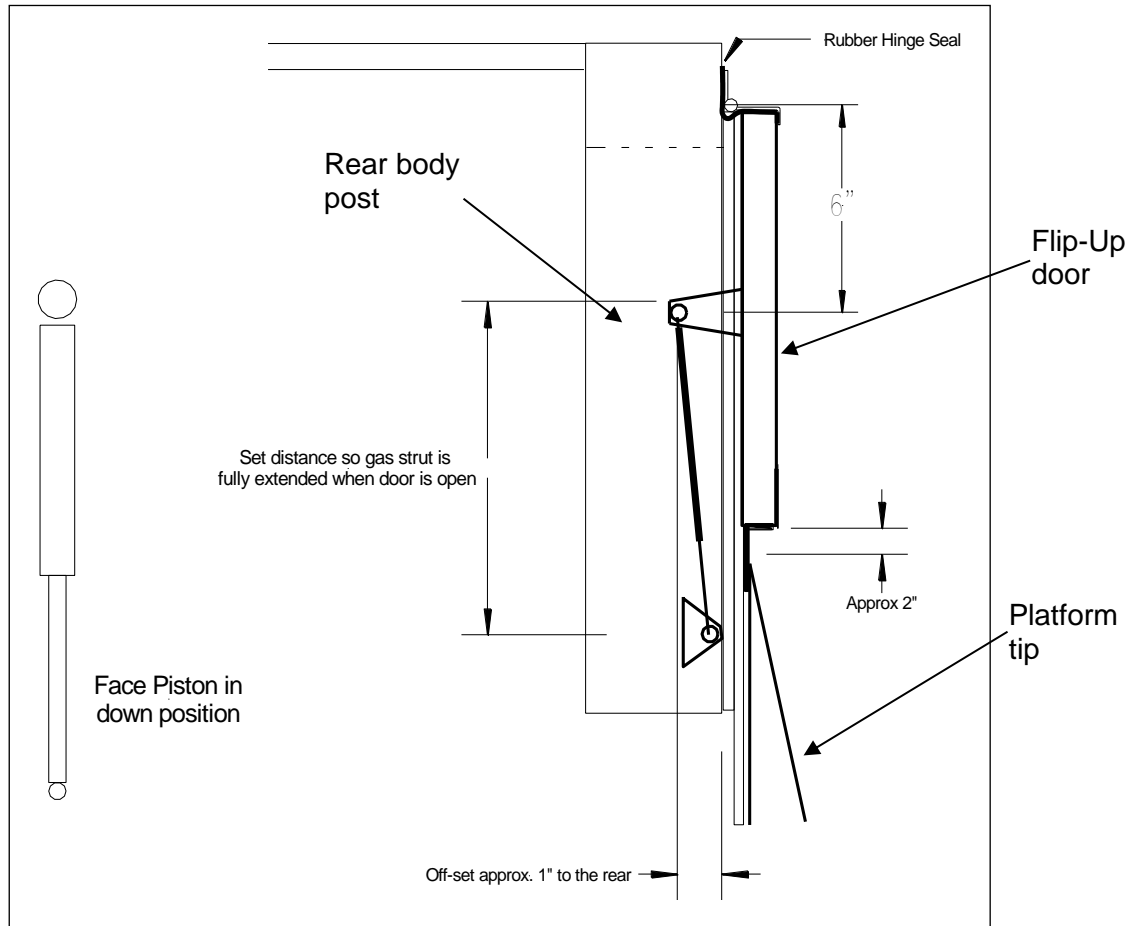

Figure 3 Flip-Up door

5. Apply Silaprene (or equivalent) to gasket channel and slide gasket into channel
6. Trim gasket flush with channel and crimp channel slightly at top and bottom to lock gasket
7. Install flip-up door
8. Verify Hinge Seal is approx 3/16" above top hinge and even before tightening any fasteners
- ⚠ Open door several times before tightening any top hinge fasteners ⚠**
9. Install lower gas strut mount so that gas strut is fully extended when door is open
10. Lower gas strut mount should be off set (approx. 1") to the rear of body to pull door in when closed

3.2 Swing Door Applications



A bridge kit is recommended for the usage of an ILQ liftgate behind swing doors. Due to the shifted pivot points all welding and cut out points have to be shifted accordingly.

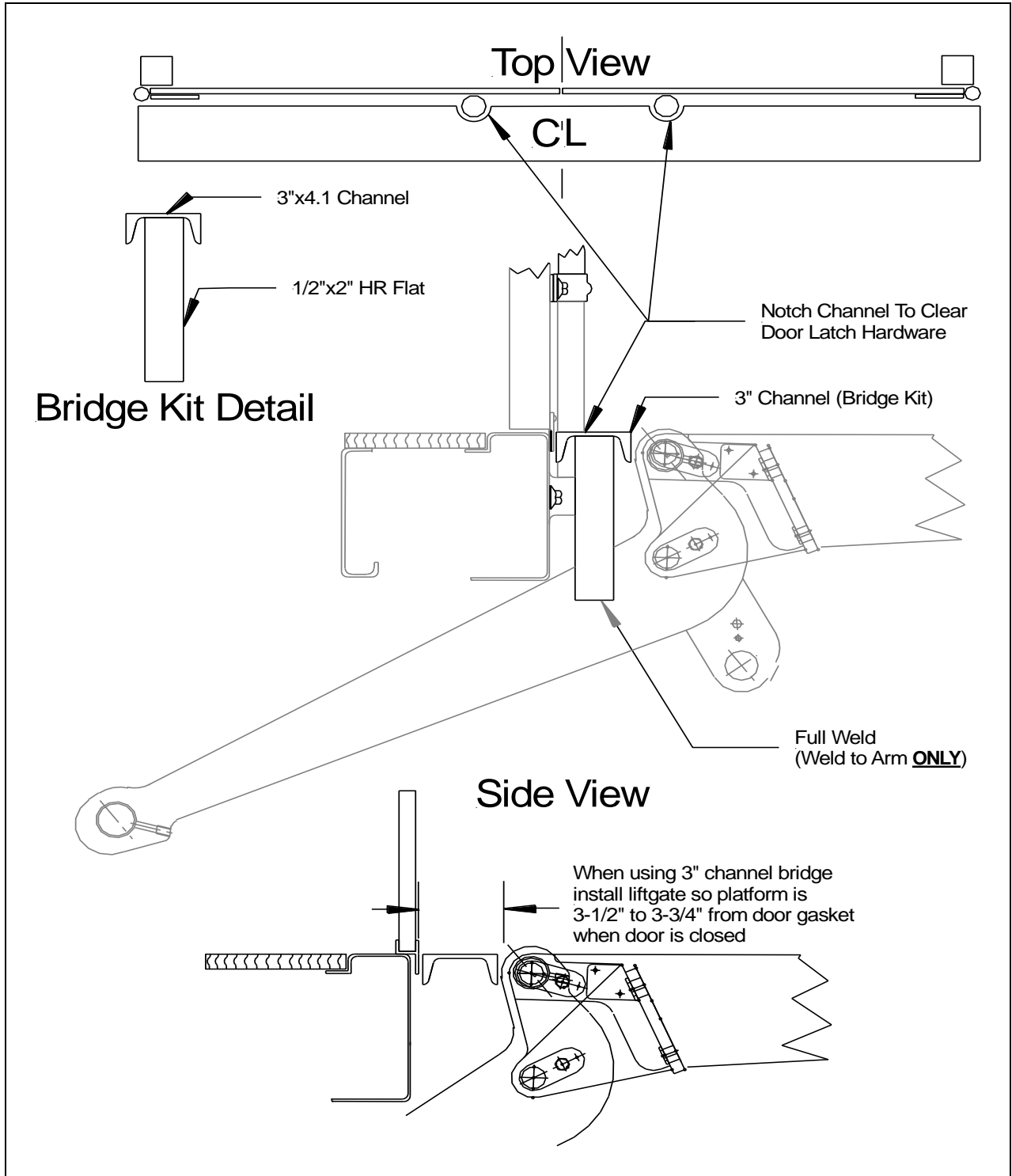

Figure 4 Bridge kit for swing door application

Please consider your particular door frame. Set up for best solution for your application.

4 Liftgate and Platform Installation



Refer to 3.1 for flip-up door/full seal kit and swing door applications **BEFORE INSTALLATION**



Refer to 4.3 for installs with Mounting Fixture **BEFORE INSTALLATION**

4.1 Sill Preparation

1. Notch rear sill if necessary per mount table for your particular model
2. Box in notch with flat bar to maintain sill strength

4.2 Mount Plate Installation

- 1) Set up mount plates (2) on top of mount frame (1)
 - 2) Connect mount plate (2) to mount frame (1) with Hex head bolts (3), lock washer (4) and (5) square washer.
 - 3) Slide mount plates in position to frame width and slide gate under truck frame.
 - 4) Tack weld mount plates (2) to frame when gate is in position and aligned.
 - 5) Double-check position of gate (centered underneath the truck)
 - 6) Tighten up hex head screws (3) to secure mount frame (1) and mount plates (2).
- Torque on screws (5) = 295 ft./lbs. [400 Nm].

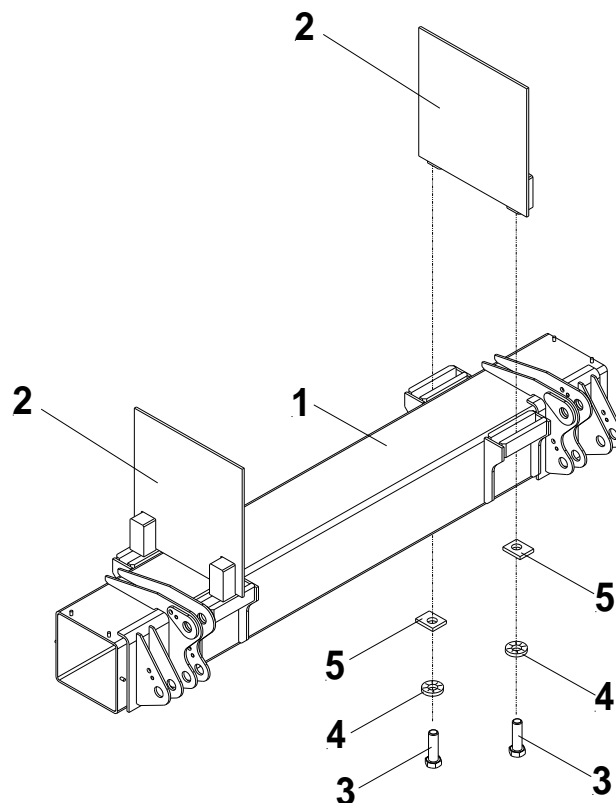

4.3 Installation with mounting fixture Sill Preparation

1. Locate and mark out the center of the rear body or bed sill.
2. Attach the INTERLIFT Liftgates mounting fixture centered to the sill by tack welding it in place. (The mounting fixture must be ordered separately from INTERLIFT Liftgates. Once purchased it can be used over and over)
3. Tie tilt cylinders with rope or wire to lift arm to avoid dragging on the ground

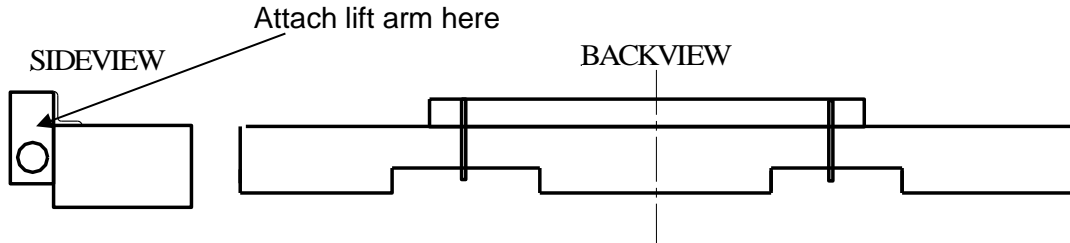

Figure 5 : Mount fixture welded to rear sill

4. Slide mount tube under the truck frame and attach the lift arm to the mounting fixture. At this point you should place the mount tube in the pre determined position, keeping the given **maximums and minimums in mind**(K- and F- dimensions). You can use a forklift, a floor jack or a similar device to position the mount tube. Make sure that you **place the tube at a 90-degree angle to the truck bed**.

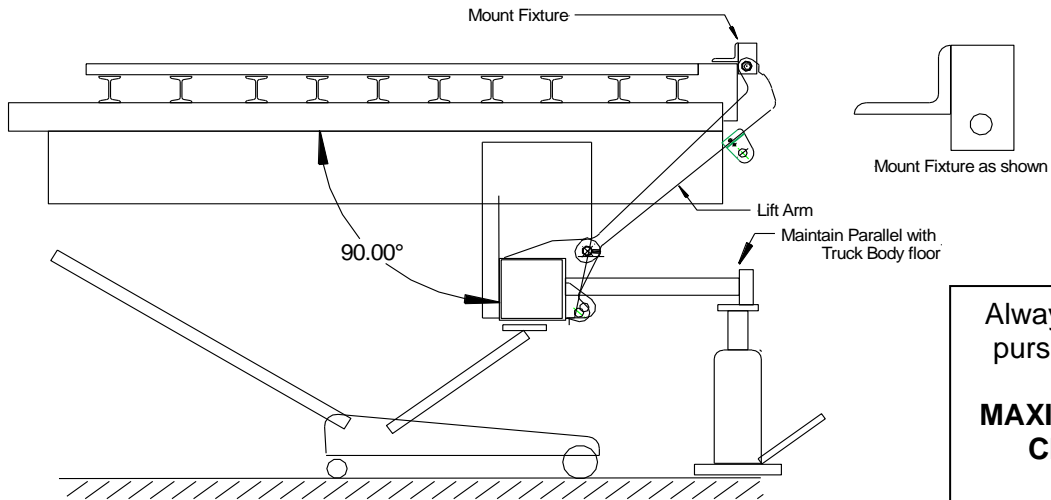

Figure 6 Mount frame alignment with fixture

5. With the mount tube held in place, position the mount plates over tube and against truck frame. Position them with angle facing to back of truck and clamp them to truck frame.



Before any welding is started, check that liftgate is balanced and not binding in mounting fixture, you should have equal pressure on each lift-arm pin. This is very important to make platform align with truck sill.



Be certain to pull out power tray before welding. IMPORTANT!!!!!!

6. The reservoir is made of plastic and you will burn it while welding. To pull out tray, open curb side mount tube rubber cover, simply remove the clamp and the tray holding bolt and detach the ground strap and control power connector for the tray. Pull on tray until the hoses are stretched and the tank is further out than the point of welding, open driver side to verify that hoses or cables are not touching inside of tube wall. Insulate the inside of the mount tube to protect the hoses from the heat during welding

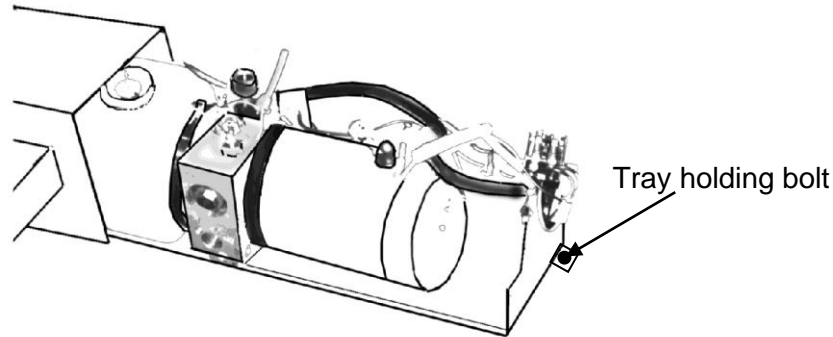
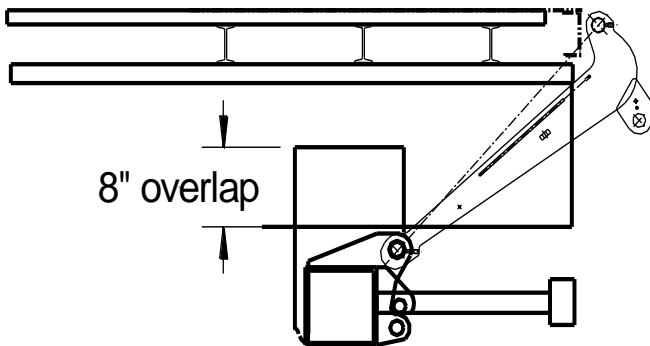

Figure 7 Track lock bolt on sliding power pack

7. Tack weld mount plates to mount tube with a minimum of three 2" and three 2" welds to the truck frame.

! Before finishing up all welding we recommend doing the electrical installation (see 5, Page 24) and platform installation (see 4.4, Page 17) to make sure that everything aligns like it should.



Use a min of 8" overlap between mount plates and truck frame
Weld 100% with 1/4" weld against the frame and both sides of the plates against the mount frame

Figure 8 Mount plate welding with overlap

! Before running the unit through its cycle, make sure that the In-Cab Switch is in the "ON" position (lights on)

! Before running the unit through its cycle, make sure that the solenoids on the lift cylinders are not hitting the mount plates.

4.4 Platform Installation

- If power pack is still removed from mount tube for welding, reconnect the ground cable and power connection. Do not push back in, welding is not finished!!!!!!

Attention: check all PC-Board connections for tightness

4.4.1 Attach platform to liftarm

1. Remove pins attached to mounting fixture and lift arm. Lift arm will drop about 12"- 16".
2. Remove mounting fixture from truck bed
3. Lower lift arm to ground to bleed air out
4. Support platform horizontally with forklift, overhead crane or similar equipment
5. Install platform onto lift arm using small pins.
6. Tighten up pin lock bolts

4.4.2 Installation and Adjusting the tilt cylinders



Pin only one cylinder at a time to the platform

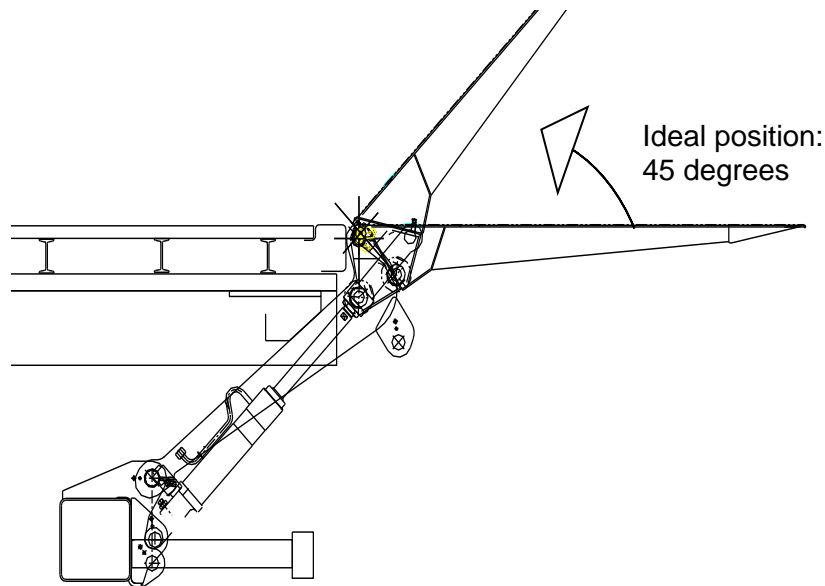

Figure 9 Attaching of platform with tilt cylinders

1. Tilt platform up to a point of easy access of the tilt bushings (using the forklift, overhead crane, etc.)
2. When installing the tilt cylinder into the platform, extend the tilting cylinder by pressing the switch for opening and closing until the pins fit in the tilt cylinder and the platform bushings. For this purpose, hold the platform sensor B-16 with the cable straight down.
3. For the platform to be in the required end position, the **tilting cylinder must be fully extended**
4. Verify that reservoir breather cap is installed and hydraulic fluid is at proper level with platform on the ground



Make sure to **tighten the tilt piston rod lock nuts** when you are finished.



Wrench Sizes for Tilt Cylinder Adjustments

Gate Model	Nut	Piston
ILQ 22	29MM	29MM

How to adjust the tilt cylinders:

1. Raise the gate all the way up against the truck body.
2. Close the platform – tilt cylinders fully extended.
3. Look for a gap at the platform tip and the body.
4. If platform is not completely in a vertical position, open up platform about 15-20 degrees and lower down about 5"-10". Adjust the tilt cylinders by rotating the piston in the cylinder head.
5. Repeat step 4 till platform is vertical and even with body
6. Tighten left and right lock nut at tilt piston to keep



Round side of tilt cylinder clevis MUST face down towards ground

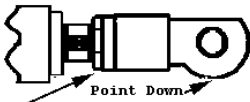

Lock nut to be tightened
when platform is stored
in vertical position



If you have not finished the welding, **carefully** run lift to see if it is properly aligned with the floor sill, remove pump & motor from tube and finish all welding work before continuing with detail work.



Never power the lift hard against anything if you have not finished welding.



4.5 Installation without mount fixture

1. Connect platform to lift arms using short pins
2. Tie tilt cylinders with rope or wire to lift arm to avoid dragging on the ground
3. Support platform with forklift, overhead crane or similar device
4. Lift platform up and support mount tube with rolling floor jack or similar device
5. Slide platform/mount tube assembly under the vehicle frame
6. Set platform so it is centered level and flush with body floor
7. Secure and attach platform to body using 3" channel or equivalent with tack welds (steel platform) or clamps (aluminum platform) to assure level position of platform to body floor (shown in Figure 4.3)



Warning: Never work or place yourself under unsupported Platform



8. Place the mount tube in the predetermined position, keeping the given maximum and minimum F- and K-Dimensions in mind. Use floor jack or a similar device to position the mount tube. Make sure that you **place the tube at a 90-degree angle to the truck bed.**

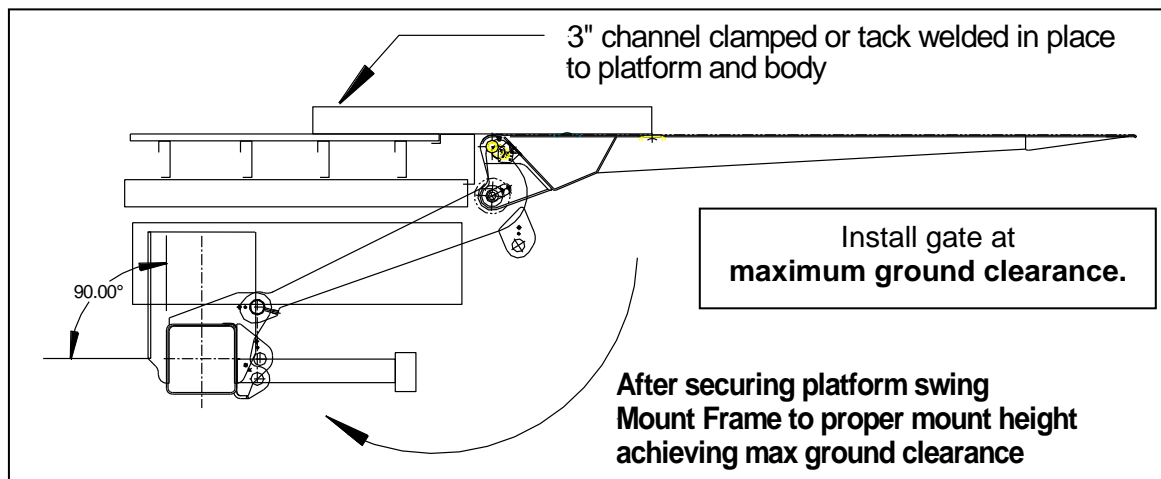

Figure 4.10: Platform install without fixture

9. When mount frame is in place, tack weld **mount plates to mount tube** with minimum three 2" welds and three 2" welds to the frame.
10. Before finishing all welding we recommend doing the electrical installation (see chapter 5 on page 24) and to make sure that everything aligns like it supposed to be.
11. Remove the 3" channel and follow instructions to install tilt cylinder as shown in **chapter 4.4.2**

4.6 Setting and Operation of B-16 Sensor

1. Mount the platform sensor B-16 to the right-hand side of the platform as shown in Fig.4.4. Make sure to **loop wire around to give it enough slack** in normal operation and route clear of any pinch points.
2. Close the platform as much as possible to body of vehicle. (**Tilting cylinder is fully extended**). Relieve tilting cylinder pressure with the 'tilt open' switch. Adjust the platform to required vertical position by turning the piston rod in or out of the clevis using a wrench (See page 18). Repeat the setting procedure if necessary. **It is important that both of the cylinders are adjusted equally.**
3. Verify that the platform sensor B-16 is set correctly by placing platform in stored position (fully vertical) and check that warning lights are off (with cab switch off). If lights still on when gate is stored, loosen the 5mm x 50mm Allen Head mount screws at sensor and rotate slightly till lights turn off. Re-tighten screws

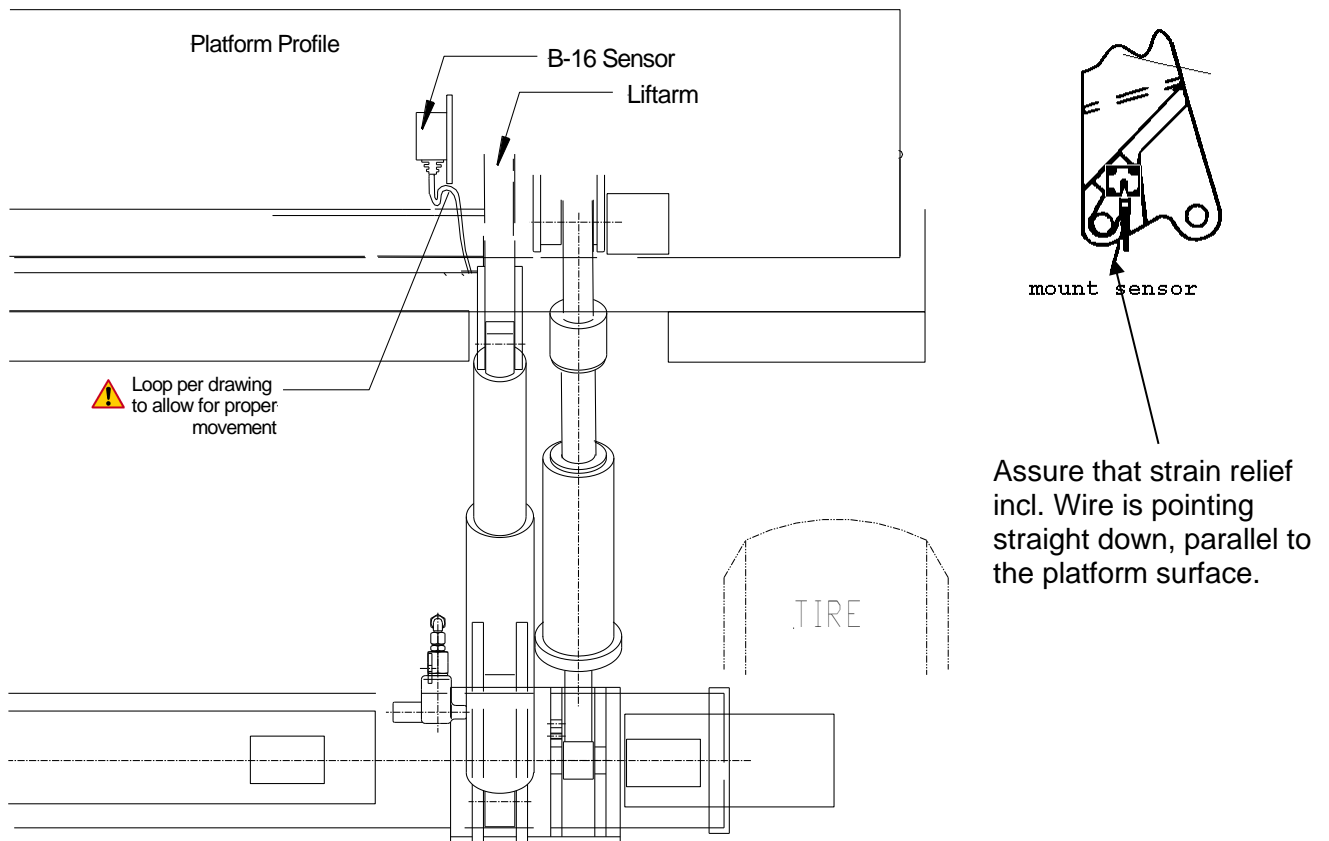

Figure 4.11: B-16 Sensor and warning light cable installation and placement



Warning Light/Foot Control (option) **MUST** have all connectors tied off and inserted into platform profile after connections are made.



Route cables secure to avoid damaging harness during regular operation

4.7 Setting and Operation of B-13 Sensor

1. Raise platform approx. 8" – 10" off ground and verify platform is level (tilt if necessary)
2. Loosen lock bolt and **set sensor level with platform surface/ground** (verify colored side of sensor is out, plastic housing is facing to lift arm)
3. Lower platform to ground. When properly set, platform should remain level for approx. 2 seconds, then tip will tilt towards ground.
4. Cycle Platform from bed height to ground several times to verify proper operation. Tilt sensor slightly forward or back to achieve proper Auto-Tilt action.

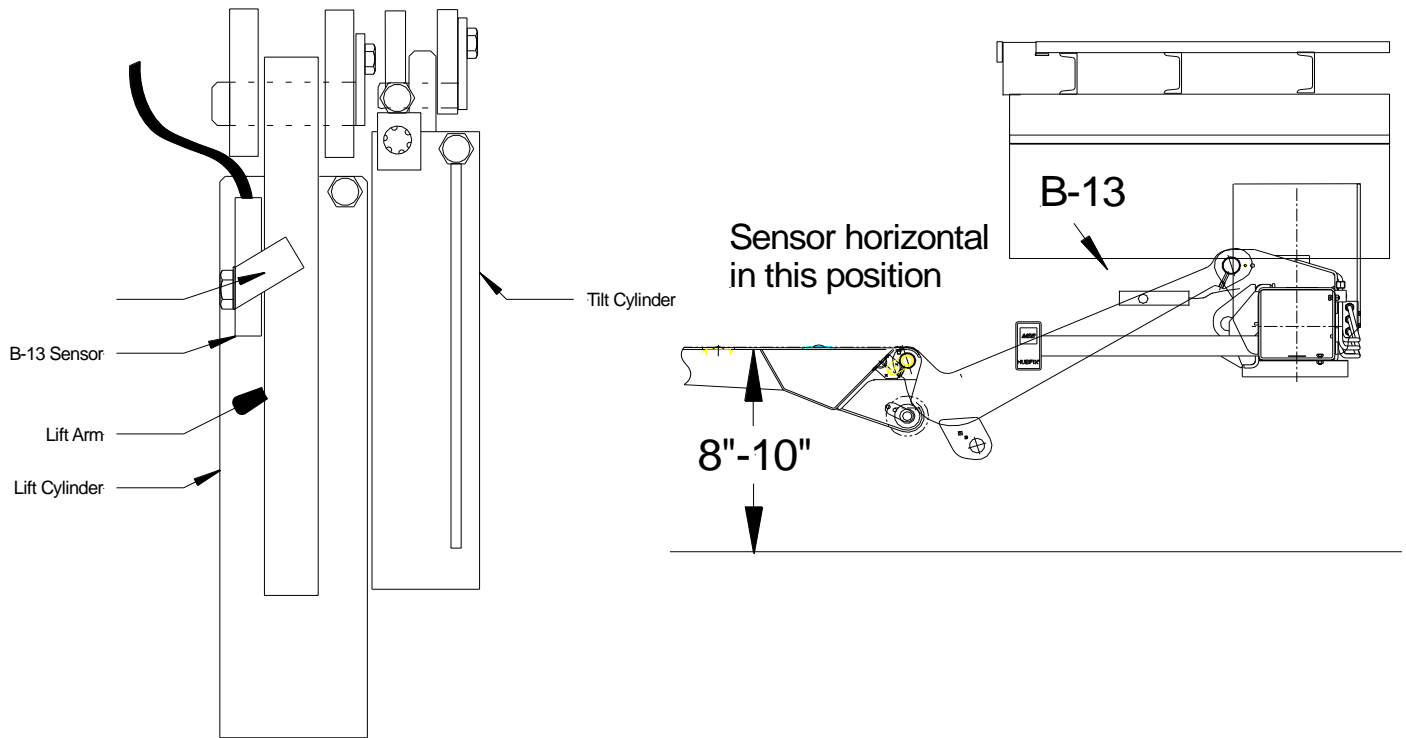

⚠ At NO time should the platform tilt towards ground while lowering. Platform should ONLY tilt AFTER Lift Arms/Nylon Rollers contact ground.

5. After sensor is properly set, tighten lock bolt to 43 in.lbs/3.5 ft.lbs
6. Cycle platform several times to check operation after tightening.
7. If Platform does not level, but lifts up only, check batteries, start truck in fast idle.
8. Fold down Lock Tab tightly onto Lift Arm (see above)

⚠ Never over torque B-13 lock bolt.

⚠ Verify colored side of sensor is out (facing away from arm)

⚠ Under torquing B-13 lock bolt may allow sensor to shift during normal gate operation.

4.8 Installation of left and right Up Stops

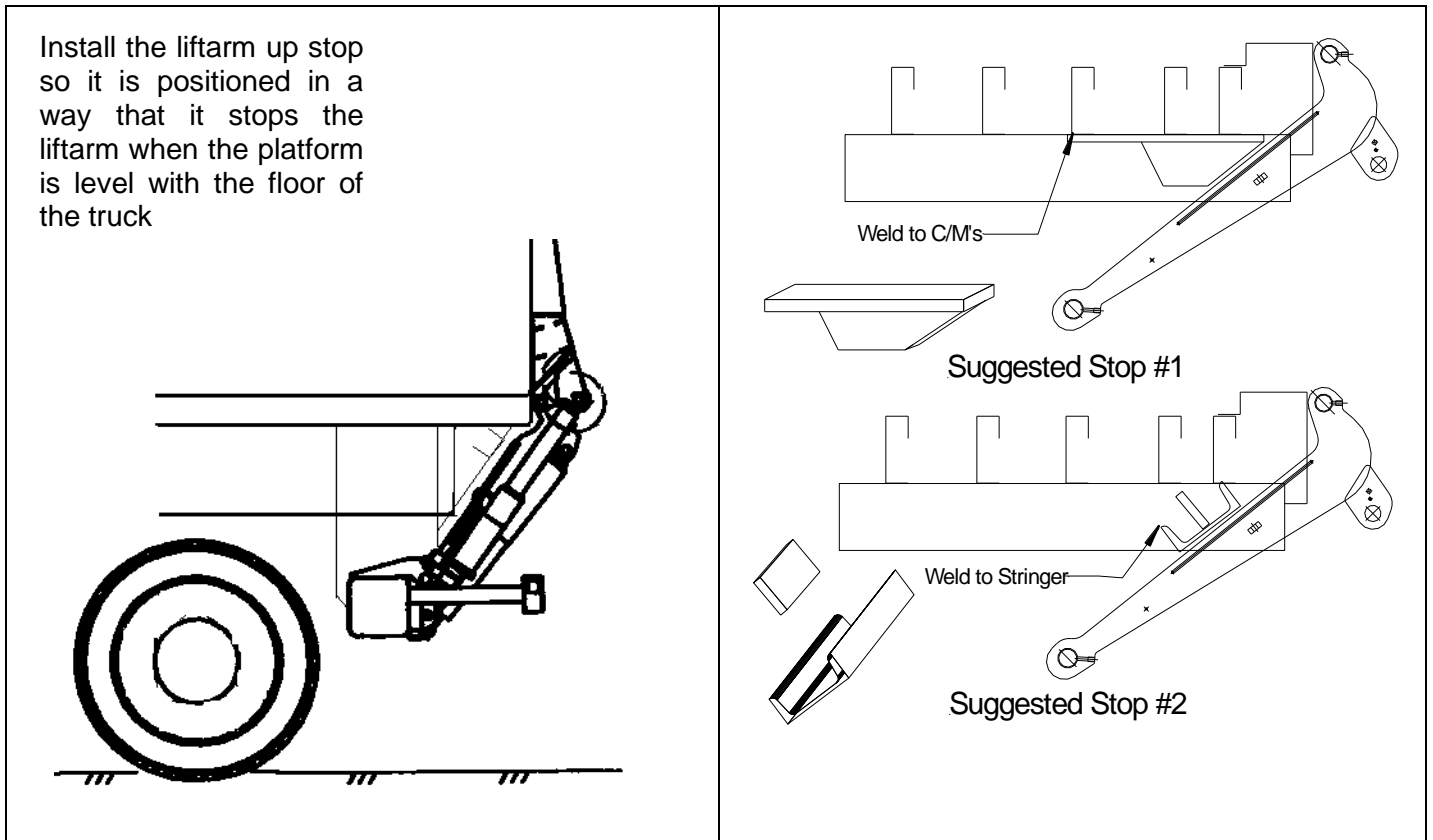

Damage to the body may occur if up stops are not installed properly



How to install the Up-stop:

1. Raise platform up to rear sill verifying it is level with body floor and there is a slight gap (appr. 1/8") between lift arm and rear sill.
2. Determine type of up stop for your installation.
3. Set up stop so that it makes contact with liftarm.
4. Tack weld in place.
5. Cycle gate to verify liftarm makes contact with left and right up stops before making contact with rear sill.
6. There **is not** an excess gap between rear sill and liftarm
7. Platform is level with body floor.

4.9 Final Welding



Make sure to have power pack pulled out and hoses and cables are away from walls when welding the tube



Protect all wires from dropping slag or splatter when welding mount plates.

1. Verify the platform is in the correct position in relation to truck sill.
2. Weld tube and mount plates with a 1/4" fillet weld 100% of the area around mount tube and around frame on both sides of plates. The plates must have a minimum of 8" of overlap on the frame. INTERLIFT Liftgates recommends adding 1/4" flat bar or plate to the top of mount plates if needed to tie Liftgate mount plates to body stringer.

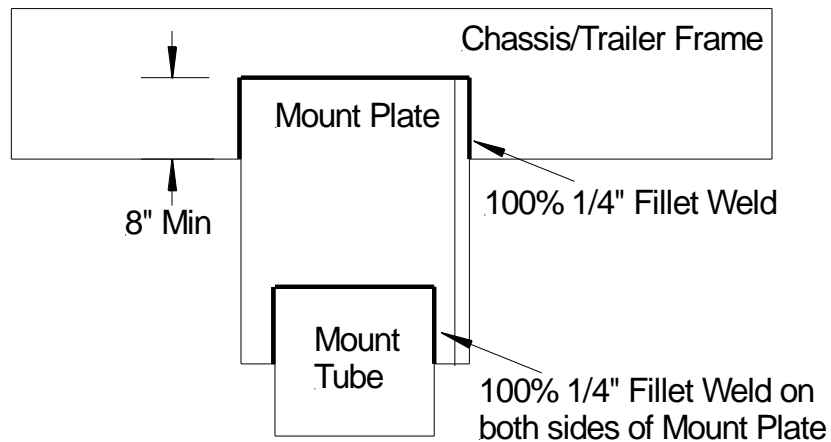

5 Electrical Installation

When performing electrical installation, please be certain to install and secure everything in a way where it is not subject to damage from moving parts, sharp edges, exhaust systems, etc.



Never exceed rating of existing fuses located at the battery and control board at the pump and motor

5.1 Main Power Connections

1. Install the 2 Ga. battery cable securely from mount frame to battery.
2. Secure the cable every 12 inches.
3. Heat shrink lug connection to cable.
4. Assure all connections are tight and securely fastened.

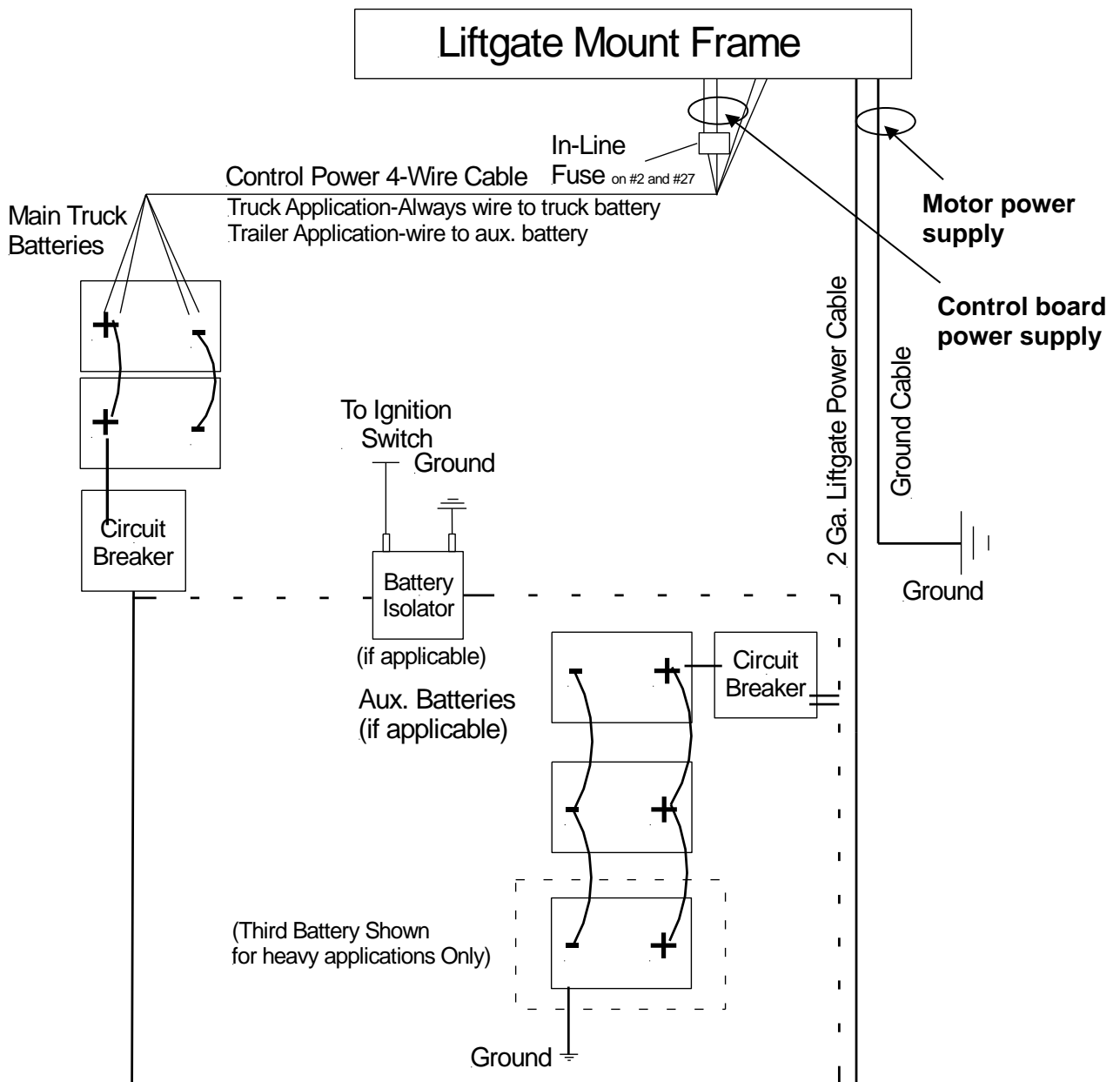

⚠ FOLLOW DOTTED LINE IF ISOLATOR OR AUXILLIARY BATTERIES INSTALLED!

⚠ Never secure cable in a way where it can make contact with other wiring, brake fuel or airlines etc or get pinched against other objects.

⚠ Never run wiring next to fuel hoses or attach to it.

Breaker Installation (Fig. 5.1)

1. Mount circuit breaker securely in battery box
2. Connect liftgate 2Ga. cable to open stud on circuit breaker
3. Connect 2Ga. jumper from forward most stud on breaker to positive battery post

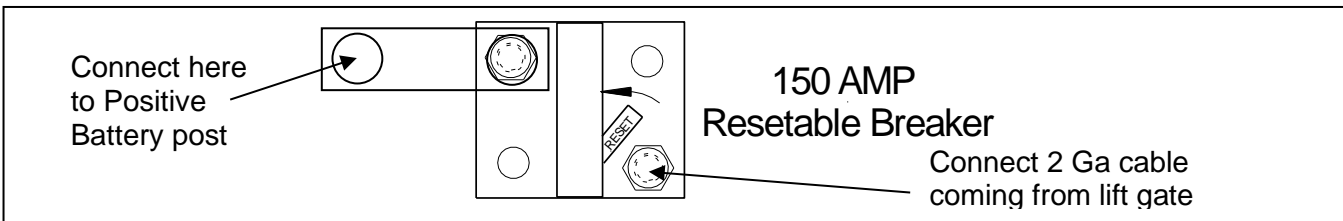
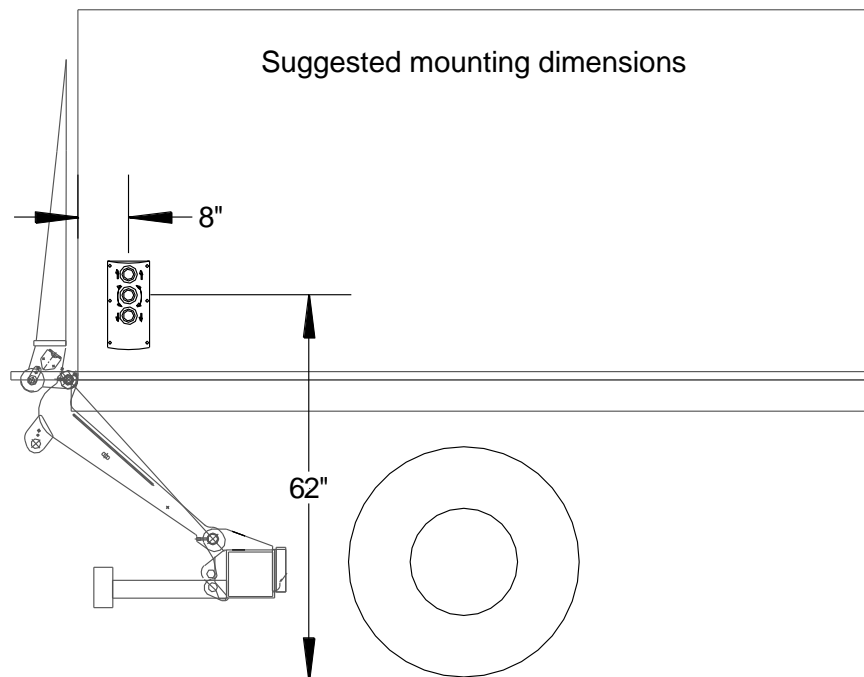

Figure 5.1: Circuit Breaker installation

- Mount circuit breaker securely in battery box or at positive battery post using supplied buss bar
 - Connect liftgate 2Ga. cable to open stud on circuit breaker
 - Connect 2Ga. jumper from open stud on breaker to positive battery post if circuit breaker was not mounted straight at battery with buss bar
1. Determine location for fixed control box; locate it in a way that the operator can view the platform and surrounding areas while operating the liftgate. Also, locate in a way where the lid does not extend out side the van body when open.



5.2 On-off switch installation

Install the cab shut-off switch inside the cab. Locate it where it can conveniently be seen and reached from the drivers seat as well as from the ground.

Place cab shut off in view of the driver and within reach from the ground.

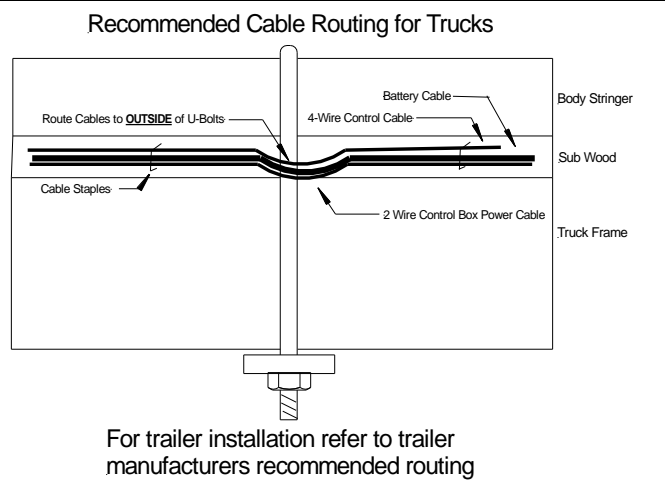
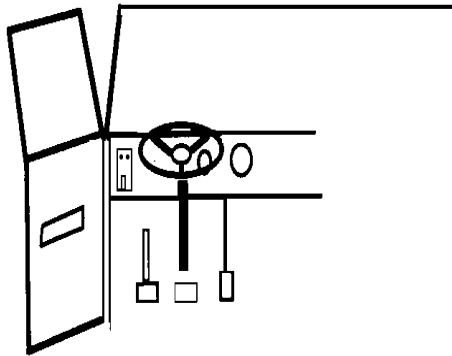

2. Lead the 4-wire cab switch together with the battery cable and the 4 wires for the control power to the batteries along the sub-wood. Secure the cable every 12 inches against the sub-wood with cable staples. Run only the cab switch into the cab. Battery cable and 4 wire control power cable will go directly to the truck battery. (#2 and #4 go to positive post **with an inline 20 amp fuse**; #1 and green/yellow go to negative post)

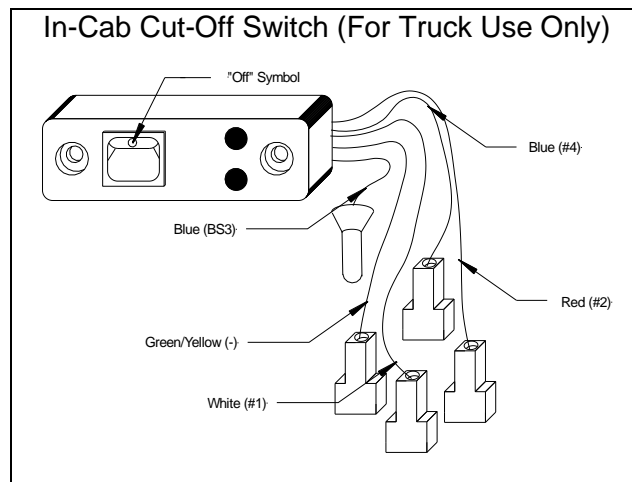

In-Cab Switch Color and Number Coding

Cable wires are marked:		Cab Cut off Switch Code	
1	= Hot Lead To Red L.E.D. Lights	-	WHITE
(-)	= Ground To L.E.D. Lights	-	GREEN YELLOW
2	= 12 Volt Power	-	RED
4	= Control Power To Liftgate	-	BLUE



Inspect and test all electrical connections, wiring and the different functions to make sure that the electrical installation is complete.

5.3 Remote Hand Control Installation



Hand Controls are NOT weatherproof and have to be stored inside body in holster or in weatherproof box (INTERLIFT Liftgates option). For “Refer”- & Flatbed installations or stored in cab solutions we recommend “plug & socket” option.

Mount Holster inside body on curb side at rear
Mount approx. 40"-48" from floor (end user needs may vary)

BUTTON NO. 1 – UP

BUTTON NO. 2 + 1 – TILT CLOSE

BUTTON NO. 2 – TILT FUNCTION ACTIVATION

BUTTON NO. 2 + 3 – TILT OPEN

BUTTON NO. 3 – DOWN

Connect all wires together according to cable ID's. Use heat-shrink to seal the connection.

3 Button Hand Control

Function	From H/C / Color	From Gate / Number
Up -	5.2 / Yellow	5.2 - #4
Down -	6.2 / Brown	6.2 - #3
12V Hot -	4.3 / Red	4 – Gn/Ye
Tilt-Up -	3.2 / White	3.2 - #1
Tilt-Down -	14.2 / Green	14.2 - #2

Optional Plug and Socket application

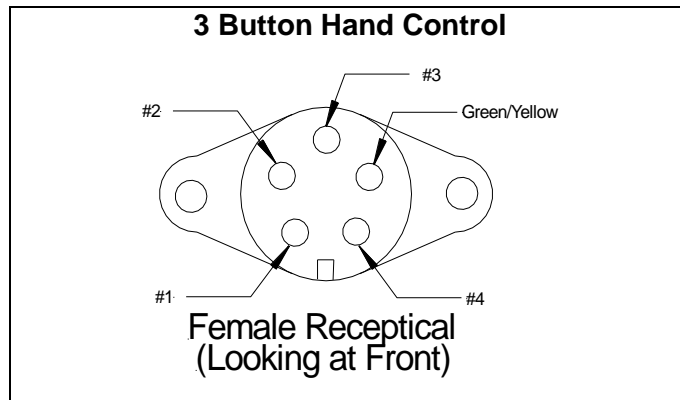

Figure 5.2: Plug & Socket wiring for Hand Control

5.4 Wiring Diagrams

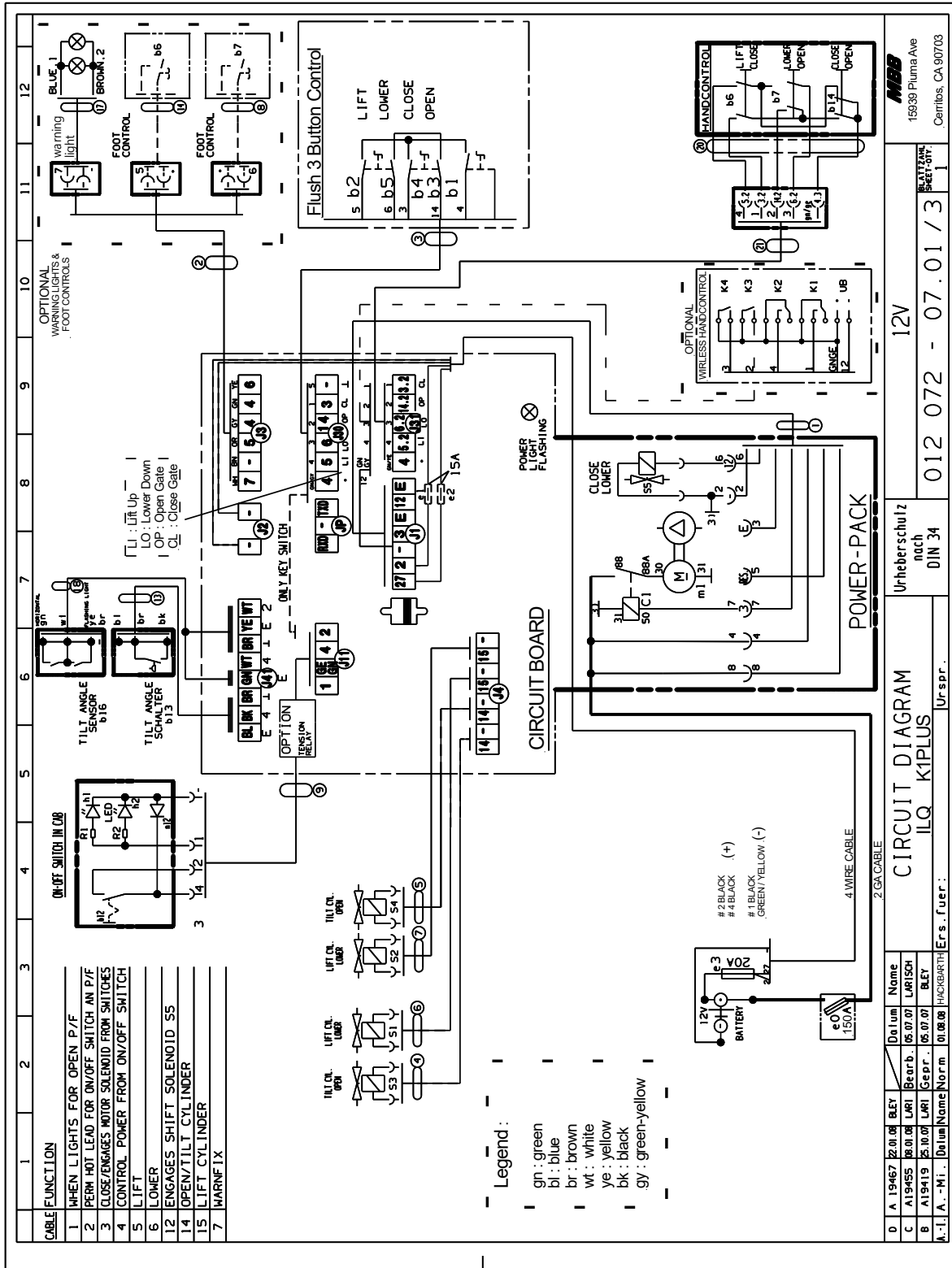

Figure 5.3: Electrical schematics

5.5 Connector Overview

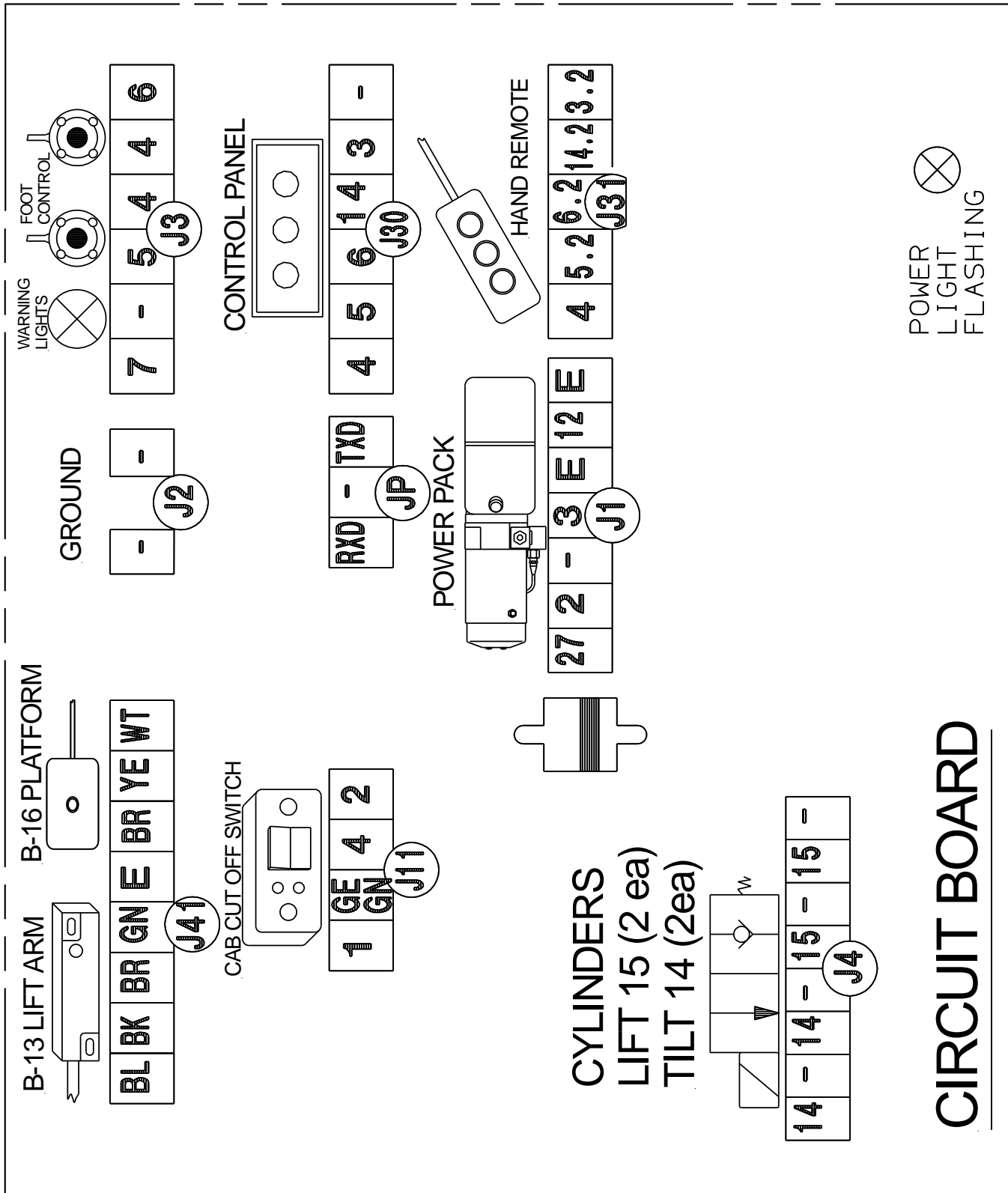

Figure 5.4: Electrical Wiring overview

5.6 Hydraulic Schematic

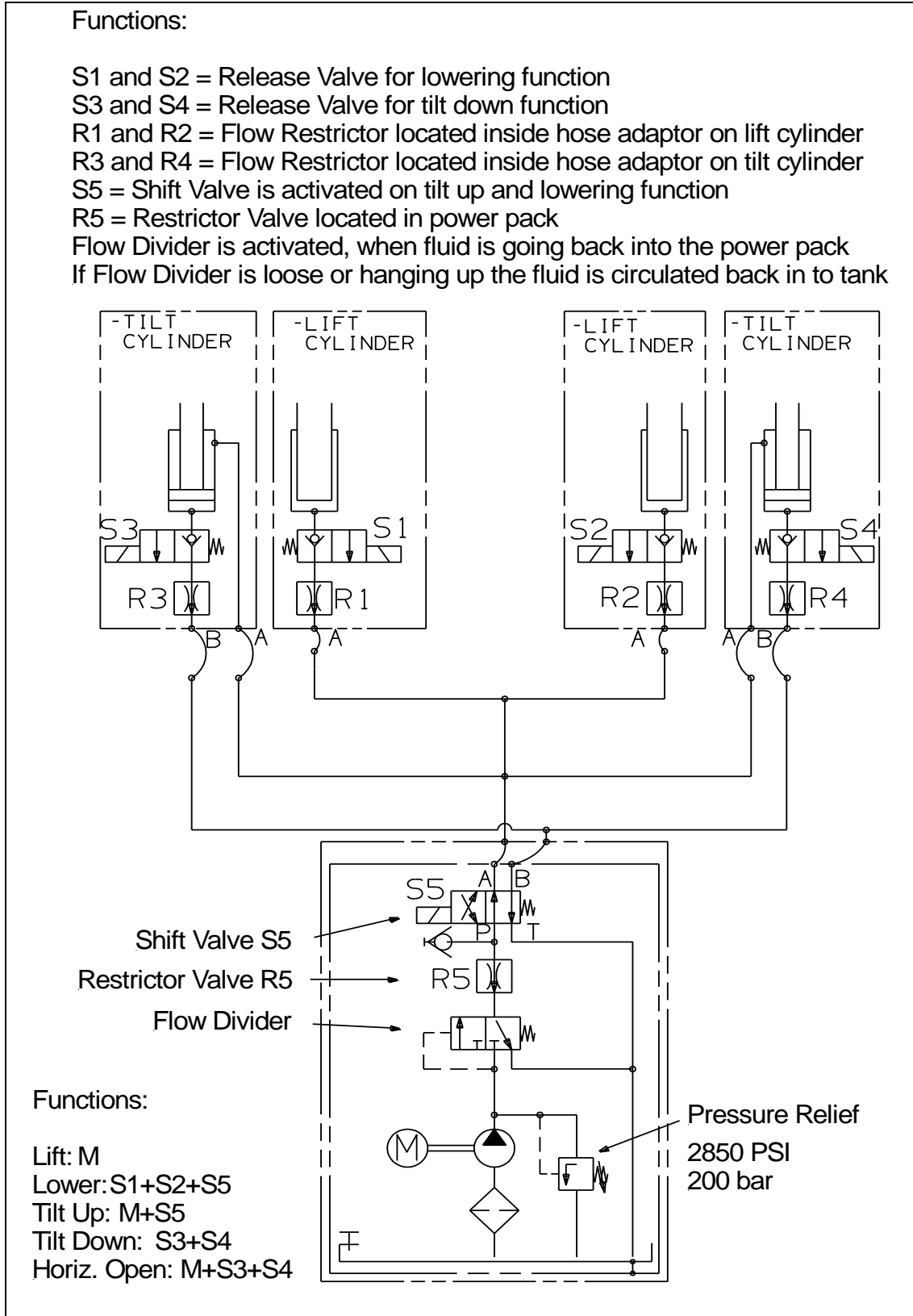

Figure 5.7: Hydraulic schematic

6 Lubrication and Final Inspection

1. Open platform and lift gate to bed level
2. Remove red caps, apply grease until grease begins to flow from bushing ends
3. Lower platform to ground and grease left over grease zerks.
4. Cycle platform open and closed several times and grease again (Fig. 6.1)
5. Wipe excess grease from joints and replace ALL red caps
- 6. Check ALL pin lock bolts for proper torque of 14 ft-lbs**
7. Paint all welded areas and area that have been scratched during installation



Note: Do not paint chrome hydraulic piston rods

8. Remove any overspray from cylinder piston rods
9. Check for any wires or hoses that may rub during operation.
10. Re-route and/or tie up wires and hoses as necessary
11. Lower platform completely to ground and slide out pump/motor to check oil level
12. Check Plugs on PC Board. Push tight and reinstall clamp on rubber cover
13. Install all operation and safety decals

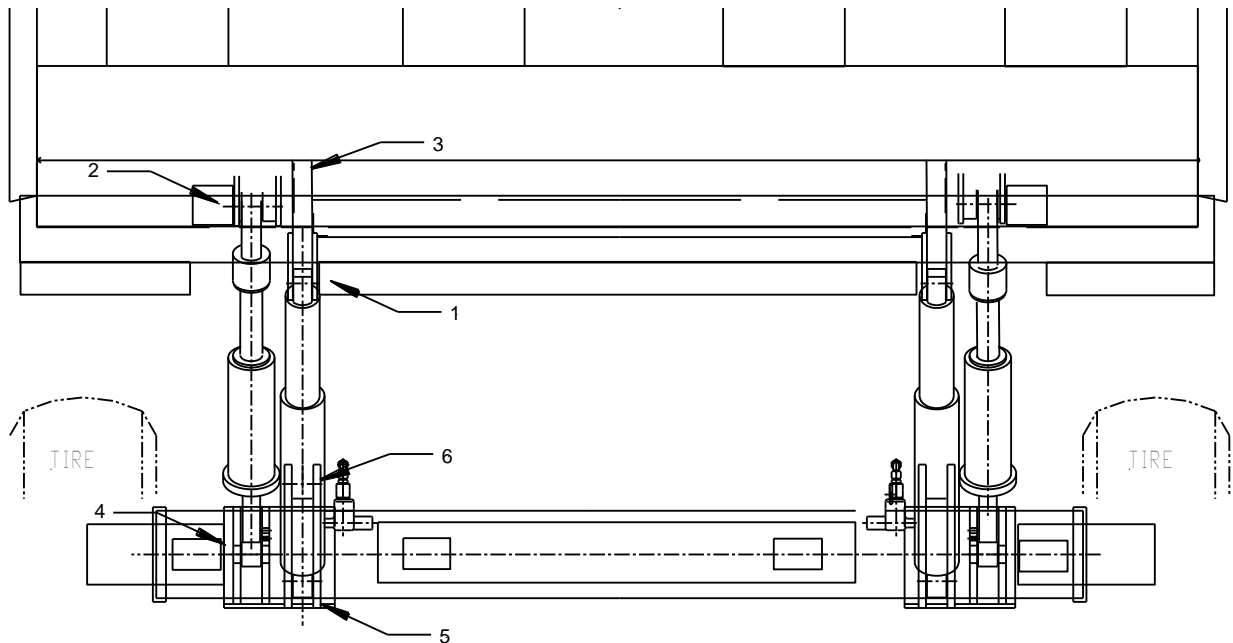
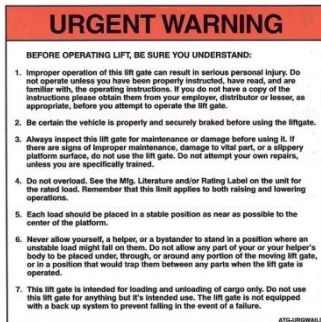

Figure 6.1: Lubrication Points (opposite direction on curb side)

6.1 Decal Placement and Inspection

For operator’s safety, all decals appearing in “Decal Kit” must be in a conspicuous place on control side of liftgate. This is typically a combination of decals on the liftgate and truck body. Please make sure to place the maximum capacity decal (D) on driver and curb side.

- (A) 1 ATG-URGWA - Urgent warning: Elevating gate instructions
- (B) 1 ATG-ILK - Main Operation (Control Box)
- (C) 2 ATG-XXXX - Max. Capacity (please check the serial number plate to find out your specific capacity)
- (D) 1 ATG-CAB - Liftgate Shut-Off (must be placed next to the Shut-Off Switch)
- (E) 1 ATG-BKR - Circuit Breaker Reset (must be located at the circuit breaker)
- (F) 2 ATG-WLH - Warning: liftgate can crush
- (G) 2 ATG-CTN - Caution: Always stand clear of platform area
- (H) 1 ATG-RESET - Circuit Breaker Protection
- (J) 1 ATG-OPENILD - Notice for Open & Close
- (K) 1 ATG-FT - Notice for Foot Control (if applicable)



Decal - A

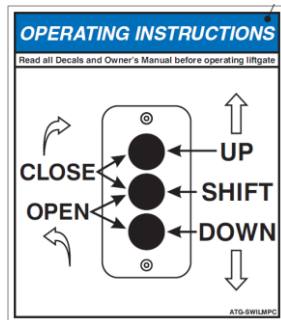

Decal - B



Decal - C



Decal - D

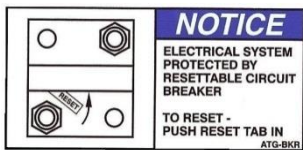

Decal - E



Decal - F



Decal - G



Decal - H



Decal - J

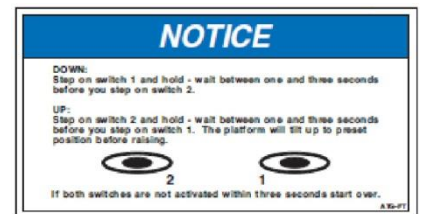

Decal - K

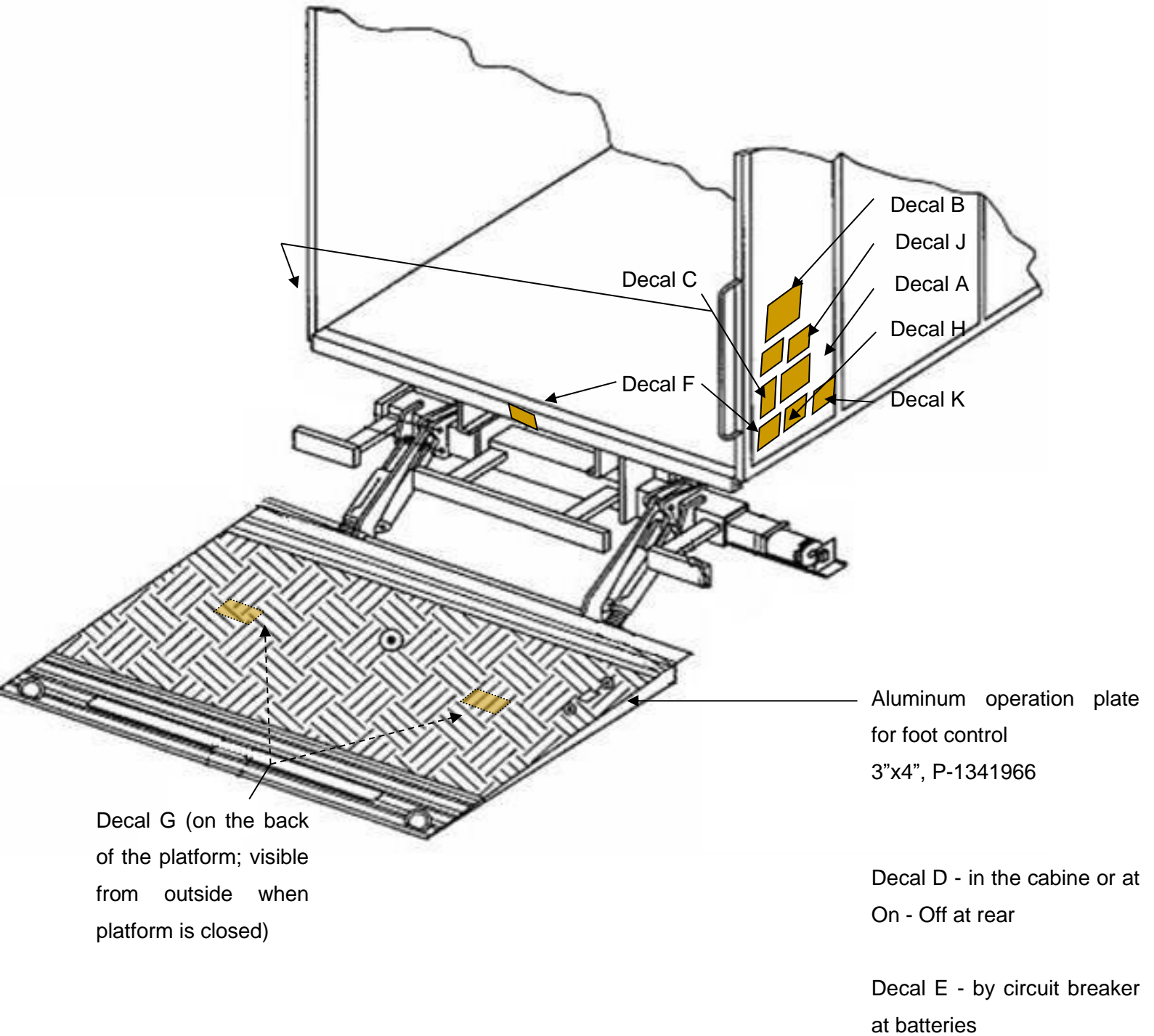
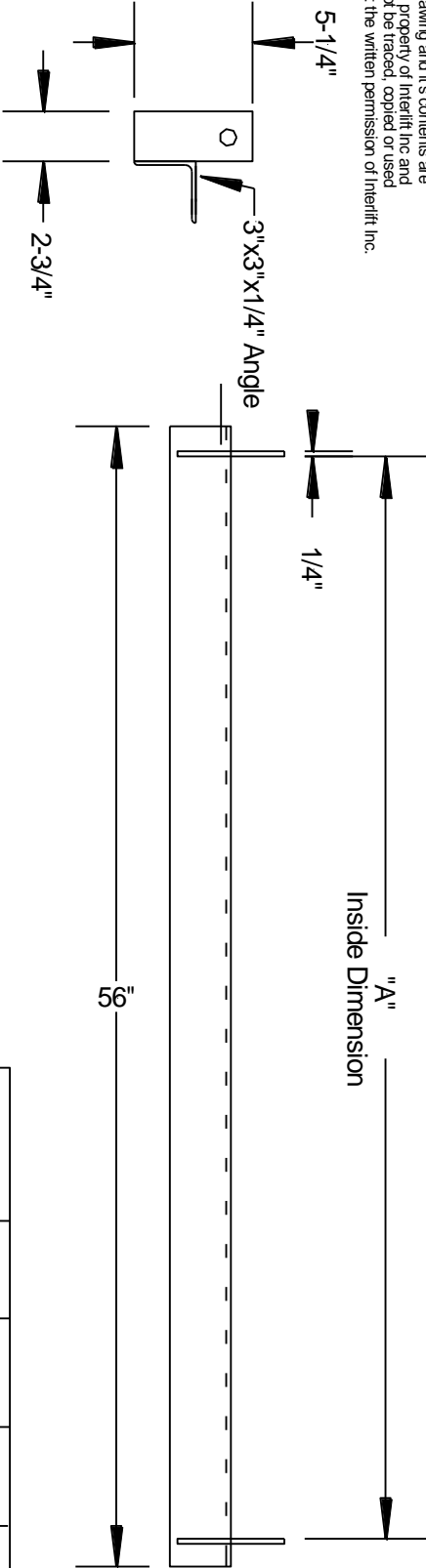
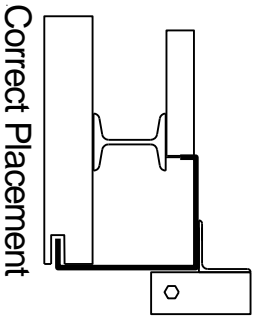
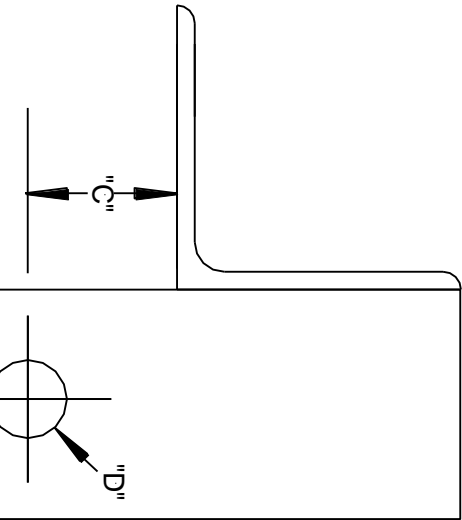

Figure 1: Decal Placement Guideline

This drawing and it's contents are the property of Interlift Inc and may not be traced, copied or used without the written permission of Interlift Inc.



Model	"A"	"B"	"C"	"D"
ILK 20/22	44-3/4"	15/16"	7/8"	1"
ILK 33	53-1/4"	1-3/8"	1-1/4"	1-1/4"
ILK 44/55	53"	1-1/2"	1-5/16"	1-7/16"
ILK 66				



Interlift Inc.
15939 Piuma Ave.
Cerritos, California 90703

Liftgate Mounting Fixture
 Drawn by: **MH** Date: **3/03/09** Rev Date:
ILK 20/22/33/44/55/66

7 Check Off Sheet

- WIRING**
- 1. Power Cord Secured
 - 2. Cables Not Rubbing Steel
 - 3. 12V Control Wire Secured
 - 4. Loomed & Stapled
 - 5. Circuit Breaker & Fuse Installed & Decal In Place
 - 6. Loop in platform sensor wire

- HYD. LINES SECURED**
- 1. No Rubbing On Frame
 - 2. No Rubbing On Platform
 - 3. Up-Down Clear
 - 4. Storing Platform Clear

- HYD. OIL LEAKS**
- 1. None At Hoses
 - 2. None Power Pack
 - 3. Cylinders

- WELDS**
- 1. Full Welds Mount Plates
 - 2. Ground Off / Clean
 - 3. Frame Capped Off

- PUMP & MOTOR**
- 1. Check Fluid With Platform On Ground
 - 2. Connections Tight With Heat Shrink
 - 3. Power Cable Tight
 - 4. Ground Cable Tight
 - 5. Breather Installed
 - 6. Cables Tied Off
 - 7. Fuses Tight
 - 8. Clamp on cover

- PINS**
- 1. Grease Zerks In Place
 - 2. Red Grease Caps On Zerks
 - 3. Bolts Tight On Pins
 - 4. Ground Rollers On

- OPERATION**
- 1. All Functions Operate On outside Control & Hand Control
 - 2. Up Stops In Place
 - 3. Platform Meets Body
 - 4. Sensor Set For Proper Auto tilt
 - 5. Warning lights stop flashing when platform stored
 - 6. Cab switch not flashing when platform stored and switch off
 - 7. Platform hits rear sill even at the same time
 - 8. Titl cylinder clevis lock nuts tight
 - 9. No Paint on cylinder shafts

- FINAL INSPECTION**
- 1. Platform Touches Ground
 - 2. Lights Working On Chassis
 - 3. Lic. Plate Bolts & Lights
 - 4. Decals Installed
 - 5. Rubber & Plastic Caps on
 - 6. Gate Painted Completely
 - 7. Body Clean Around Gate
 - 8. Pin Greased - 12 Places
 - 9. Cylinders Clean
 - 10. Clamp on cover
 - 11. Exhaust mud flaps are ok

- OPTIONS**
- 1. All Options On Gate
 - 2. Circuit Breaker Tight
 - 3. Cart Stops Working

CHECKED BY _____

DATE _____

Note:

This must be filled out and kept for your records. A copy of this sheet must be presented to INTERLIFT Liftgates for any warranty compensation

