

# ***INTERLIFT***

**BY PALFINGER**

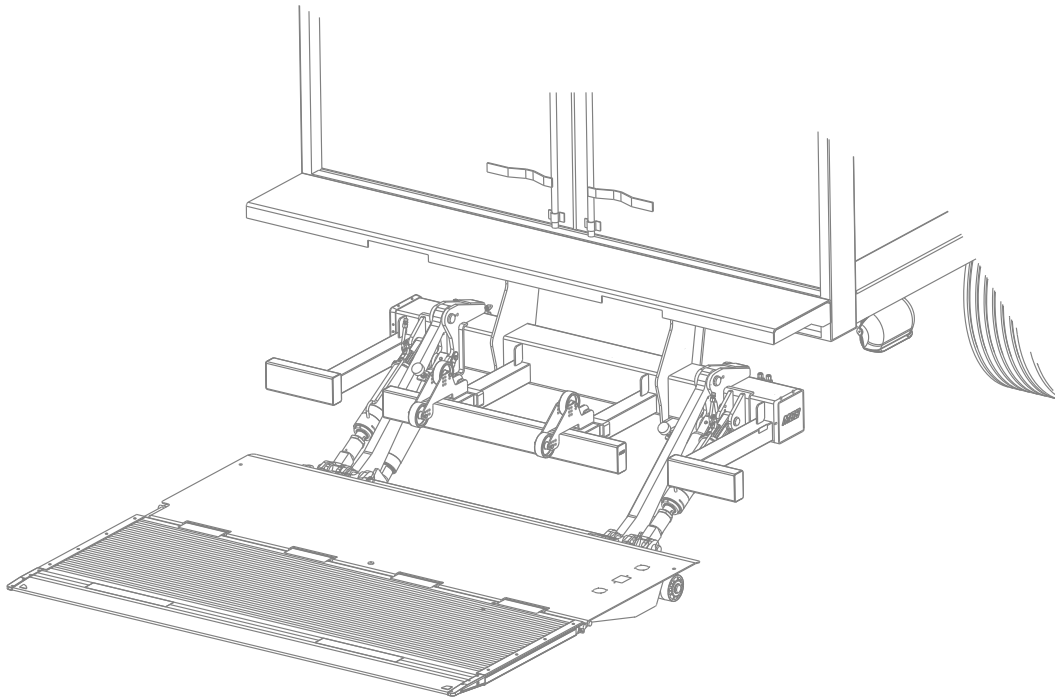
---

## **OWNER'S MANUAL**

**ILF 33, 3300 lbs. Capacity**

**ILF 44, 4400 lbs. Capacity**

**ILF 55, 5500 lbs. Capacity**



ILF 33/44/55 Owner's Manual  
Document Part Number: 90-0813-100 / 13-696\_90-00\_01-00  
ECN-M1723, Rev. 1.6, 01-23-24  
Copyright © 2023 Palfinger Interlift, LLC.  
All rights reserved.

Information in this document is subject to change without notice.  
Visit [www.palfinger.com](http://www.palfinger.com) for up to date information and notifications.

If you received this product with damaged or missing parts,  
contact INTERLIFT Liftgates at (888)-774-5844

Parts Order/Inquiries  
[liftgateparts@palfinger.com](mailto:liftgateparts@palfinger.com)

Technical Support  
[technicalapplications@palfinger.com](mailto:technicalapplications@palfinger.com)



15939 Piuma Ave.  
Cerritos, CA 90703  
Tel (888) 774-5844  
Fax (562) 924-8318



572 Whitehead Road.  
Trenton, NJ 08619  
Tel (609) 587-4200  
Fax (609) 587-4201

---

## Table of Contents

<b>1</b>	<b>Manual Updates .....</b>	<b>5</b>
<b>2</b>	<b>Important Notes .....</b>	<b>6</b>
2.1	Attention .....	6
2.2	Important Notes .....	6
2.3	General Information .....	7
<b>3</b>	<b>Safety Information .....</b>	<b>9</b>
<b>4</b>	<b>Overview .....</b>	<b>10</b>
4.1	General View of Liftgate.....	10
<b>5</b>	<b>Maximum Load and Placing of Load on Platform .....</b>	<b>11</b>
<b>6</b>	<b>Operation of Liftgate .....</b>	<b>12</b>
6.1	Liftgate Operation .....	12
6.2	Platform Cart Stops (Optional) .....	16
6.3	3-Button Hand Held Remote Control.....	17
6.4	Operation by Foot Control (Optional) .....	18
6.5	Operation by Wireless Hand Held Remote (Optional) .....	18
<b>7</b>	<b>Preventive Maintenance and Quick Check .....</b>	<b>19</b>
7.1	Maintenance and Care.....	19
7.2	Lubrication .....	20
7.3	Checking and Changing Oil .....	21
7.3.1	Recommended Hydraulic Fluids.....	21
7.4	Decal Placement and Inspection.....	22
7.5	Quick Check List.....	24
<b>8</b>	<b>Troubleshooting .....</b>	<b>25</b>
8.1	Liftgate will not power on.....	26
8.2	On-Off L.E.D.s are on but all functions are dead .....	28
8.3	L.E.D.s continue to stay on, after switch is turned off .....	28
8.4	Platform tilts down before it reaches the ground.....	28
8.5	Main Power Connections .....	29
8.6	Electrical Schematic.....	30
8.7	Control Board Connector Overview.....	31
8.8	Hydraulic Schematic .....	32
<b>9</b>	<b>Needed Information for Ordering Spare Parts and Repairs.....</b>	<b>33</b>
9.1	Ordering Spare Parts .....	33
9.2	Repairs .....	33

---

<b>10</b>	<b>Warranty.....</b>	<b>33</b>
<b>11</b>	<b>Contact Address.....</b>	<b>34</b>

**Company Information:**

**Company Name:** \_\_\_\_\_

**Advisor Name:** \_\_\_\_\_

**Trailer Year Make & Model:** \_\_\_\_\_

**Liftgate Information:**

**Liftgate Serial Number:** \_\_\_\_\_

**Liftgate Model Number:** \_\_\_\_\_

**Date of Purchase:** \_\_\_\_\_

**Date of Installation:** \_\_\_\_\_

**Thank you for choosing INTERLIFT Liftgates.**

## 1 Manual Updates

Revision	Description
v1.5	<ul style="list-style-type: none"><li>• Updated Section 5: Liftgate Operation.</li><li>• Updated Section 7.3: New Operating Instructions decal added.</li><li>• Added Platform Cart Stops operation, Section 6.2.</li></ul>
v1.6	<ul style="list-style-type: none"><li>• Changed the logos, from Palfinger to Interlift</li></ul>

## 2 Important Notes

### 2.1 Attention

Before starting any operations of the liftgate, please read and understand this OWNER'S MANUAL. Its intention is to act as a guide for the operation personal as well as to give help with preventive maintenance but does not take place of unauthorized usage or repair by unqualified personnel.

Please contact your nearest INTERLIFT Liftgates distributor or INTERLIFT Liftgates in California or New Jersey for assistance if you have questions regarding installation, operation or maintenance.

This owner's manual applies to the following models: **ILF 33, 44, 55**



This is the safety alert symbol. It is used to alert you to potential personal injury hazards. Obey all safety messages that follow this symbol to avoid possible injury.

### 2.2 Important Notes

The ILF is a unique 4 cylinder design able to virtually fold and unfold with the push of a button and maintain level throughout the ride.

The Hydraulic Power Unit (HPU) is easily accessible for service and exchange. The whole assembly slides out and can be serviced at that point. To exchange the HPU, two hoses and the battery cables need to be disconnected. The platform is supported by two arms linked with a torsion tube.

A three piece under ride guard is preinstalled on the liftgate. Lifting actions are carried out by hydraulic cylinders mounted on the lift arms.

The platform's tilting actions are controlled by two hydraulic cylinders on each side of the liftarms. This enables the platform to maintain in a horizontal position throughout the lift mode, regardless of the terrain.

The hydraulic cylinders are equipped with solenoid operated valves located at the port of the cylinder which prevents the platform from lowering accidentally unless the operator is activating the controls. This system also enables you to store the liftgate without a separate platform latch.

The piston rods are treated against corrosion and might also be protected with plastic or rubber boots to protect from road gravel and dirt. The HPU is equipped with a built-in pressure relief valve, which prevents overloading when lifting and tilting up.



**The valves do not prevent overloading of the platform when lowering or tilting down.**



The electric supply is taken from the vehicle battery. If the vehicle battery is not sufficient, an auxiliary battery kit needs to be installed. The electric control power is secured via a 20 Amp fuse and an on-off switch located inside the cab. The switch has L.E.D. lights, indicating when the control power is on. (Trailer application has an on-off switch located in the lockable control box).

The liftgate is operated from a standard lockable control box located on the curbside underneath the van body. A standard hand held remote control is also supplied with the lift. A variety of different product options can be purchased with the liftgate as well.

## 2.3 General Information

### REMEMBER!

It is the fleet manager's responsibility to educate the operator on the liftgate and its intended use. The operator's attention should be drawn to the permitted load limits and an understanding of the operation to ensure the safety throughout the operation.

### ONE-MAN OPERATION!

Never let an "outsider" operate the liftgate while you are handling the cargo.

A "misunderstanding" can result in serious personal injury.



In the interest of safety it is important that all operating personnel properly understand the functions of the liftgate, possible hazards, dangers, the load limits and load positioning for that specific unit.

### IMPORTANT NOTICE!



Before the operator uses the liftgate, they should be thoroughly familiar with the lift's functions and usage according to the following:

1. Improper operation of this lift can result in serious personal injury. Do not operate unless you have been properly instructed, have read and are familiar with the operation instructions. If you do not have a copy of the instructions please obtain them from your employer, distributor or lessor, as appropriate, before you attempt to operate the lift.
2. Be certain the vehicle is properly and securely stopped before using the lift.
3. Always maintain the liftgate and inspect it for damage before usage. If there are signs of improper maintenance, damage to vital parts, or slippery platform surface, do not use the lift. Do not attempt your own repairs unless you are specifically trained.
4. Do not overload. See the Rating Label on the unit for the rated load. Remember that this limit applies to both raising and lowering operations.
5. Each load should be placed in a stable position as near as possible to the body of the truck/trailer.
6. Never stand in, move through or allow anyone else to stand in or move through the area in which the lift operates, including that area in which a load might fall.

7. This is not a passenger lift. Do not ride the lift with unstable loads or in such a manner that a failure would endanger you. The lift is not equipped with a back-up system to prevent falling cargo in the event of a failure.

**The maximum loads must be observed and followed!**



**IMPROPER USE**



It is not permitted to use the liftgate:

- As an elevating work platform.
- To push loads.
- To carry people (Only the operator may travel on the platform).
- To clear snow.

Please read through the operational and technical description of the INTERLIFT Liftgates Liftgate.



### 3 Safety Information

This manual follows the guidelines set forth in "ANSI Z535.4-2007" for alerting you to possible hazards and their potential severity.



This is the safety alert symbol. It is used to alert you to potential personal injury hazards. Obey all safety messages that follow this symbol to avoid possible injury or death.

#### **DANGER**

**! DANGER** indicates an imminently hazardous situation which, if not avoided, will result in death or serious injury.

#### **WARNING**

**! WARNING** indicates potentially hazardous situation which, if not avoided, could result in death or serious injury.

#### **CAUTION**

**! CAUTION** indicates a potentially hazardous situation which, if not avoided, may result minor or moderate injury.

#### **CAUTION**

**CAUTION** without the safety alert symbol is used to address practices not related to personal injury. (*In this manual we use it to alert you to potentially hazardous situation which, if not avoided, may result in property damage.*)

#### **NOTICE**

**NOTICE** without the safety alert symbol is used to address practices not related to personal injury. (*In this manual we use it to alert you to special instructions, steps, or procedures.*)

This Manual has been designed for use in conjunction with the ILF series liftgates only, which is designed for different capacities. You have different options to determine the type of your Liftgate:

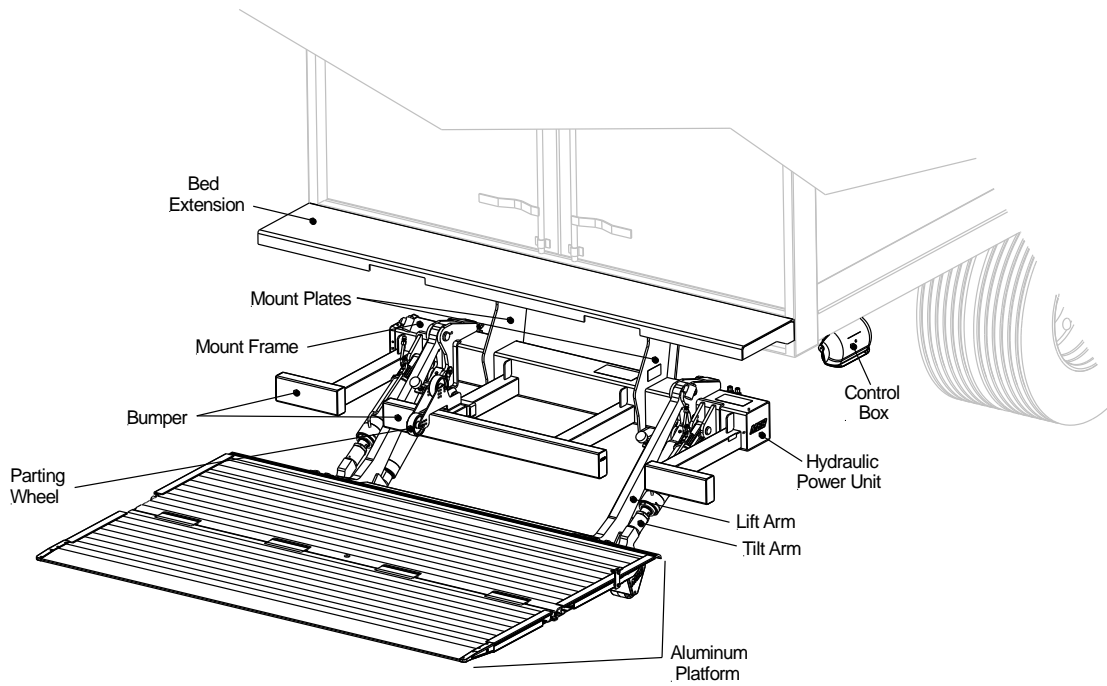
- 1) Refer to the serial number tag on the Liftgate (Driver Side on Top of Mount Frame).
- 2) Ask your employer or lessor.
- 3) Call your INTERLIFT Liftgates Authorized Service Center for assistance.
- 4) Call INTERLIFT Liftgates for assistance in the USA at 888-774-5844. You can also contact INTERLIFT Liftgates by fax (562) 924-8318, or on the internet- [www.PALFINGER.com](http://www.PALFINGER.com).

If you are facing any problems or are in need of repair, contact INTERLIFT Liftgates for information regarding experienced and trained Authorized Service Center in your area.

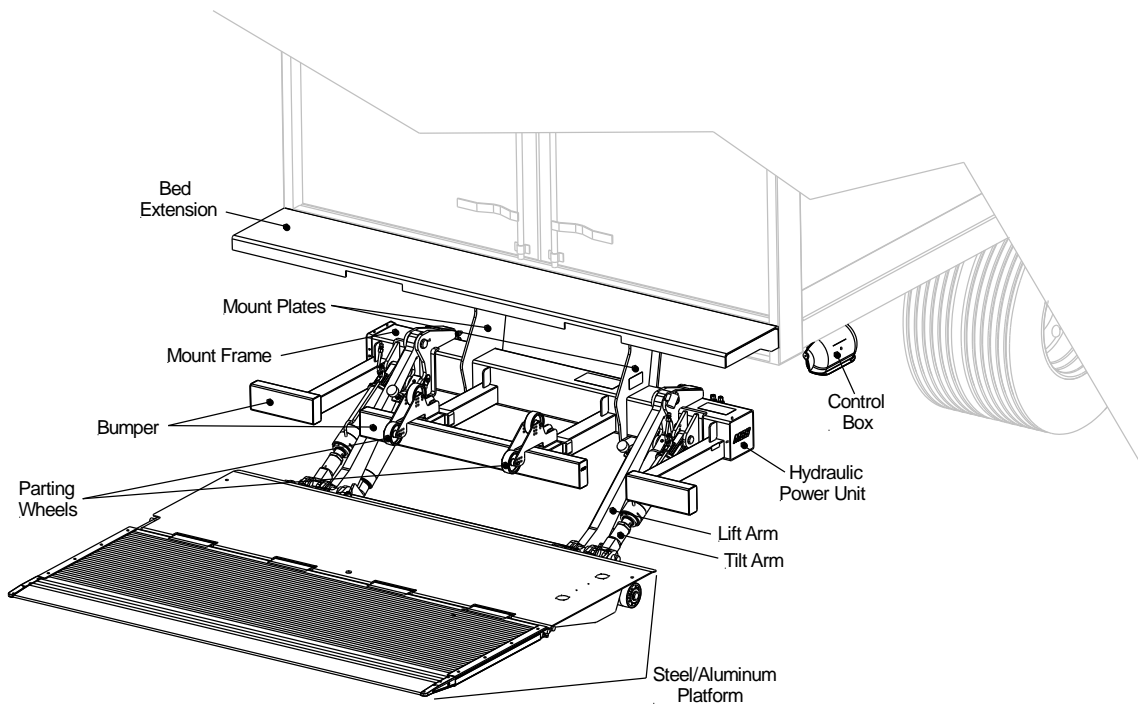
*Replacement manuals are available for download at [www.palfinger.com](http://www.palfinger.com)*

# 4 Overview

## 4.1 General View of Liftgate



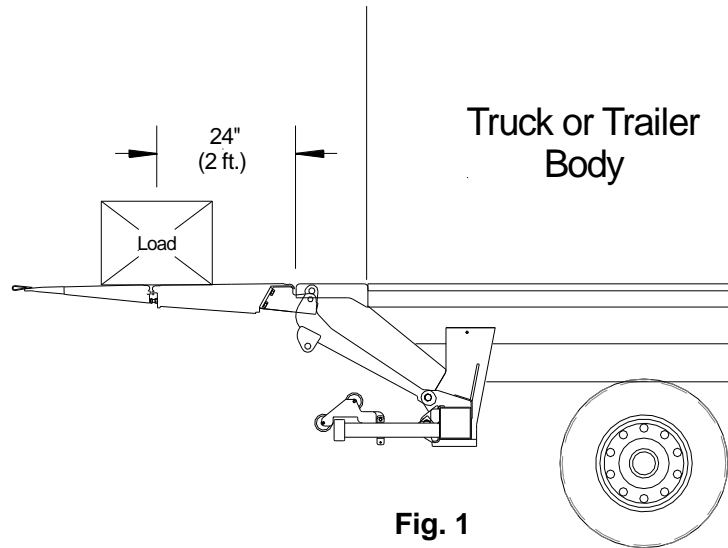
**ILF 33**



**ILF 44/55**

## 5 Maximum Load and Placing of Load on Platform

Every INTERLIFT Liftgate is rated for a maximum load. The point of maximum load is rated at a defined distance. The center point of maximum load is at 24" from the front of the platform, **Fig.1**.

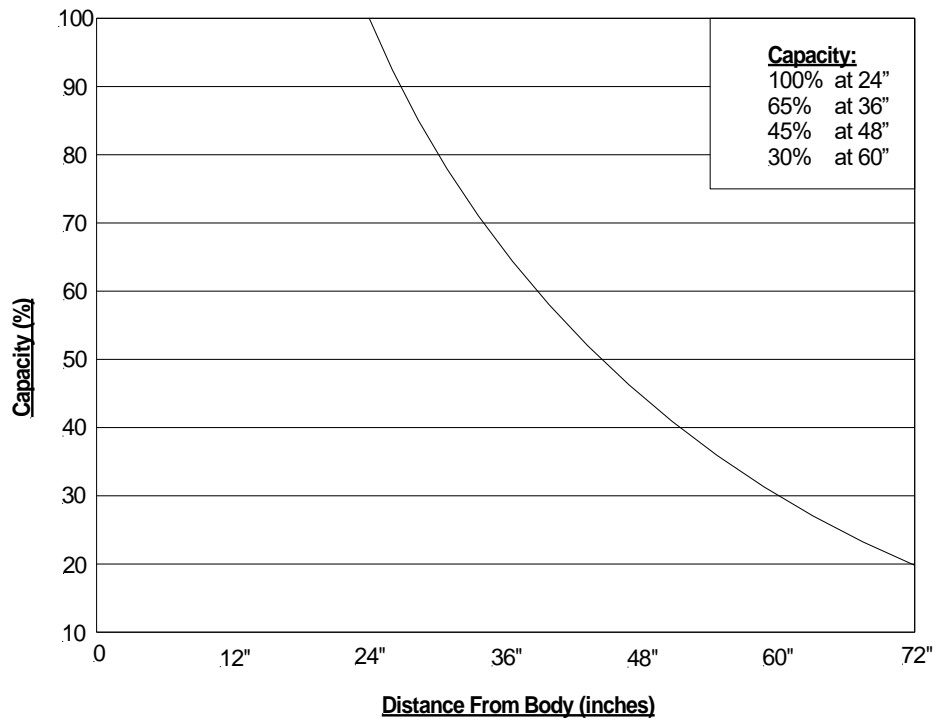


**Fig. 1**



By increasing this distance the maximum load of the liftgate is decreasing. An overview about the rating depending, on the distance from the end of the platform is shown in the following load diagram, **Fig. 2**.

### Load Diagram



**Fig. 2**

# 6 Operation of Liftgate

## 6.1 Liftgate Operation

### NOTICE

It is highly recommended to have batteries completely charged before operating the liftgate.

Switch the liftgate ON. ON/OFF switch for trailers are on the control box and for trucks the switch will be inside the cab, Fig. 3.

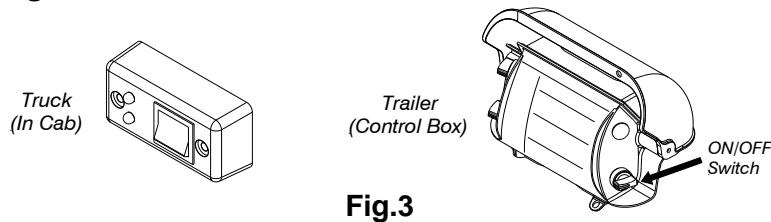


Fig.3

### To Unfold Platform - Follow Steps 1A-4A

1A. Turn the Lift switch Down until the platform wheels contact the ground and the platform rests on the roller wheels, Fig. 4.

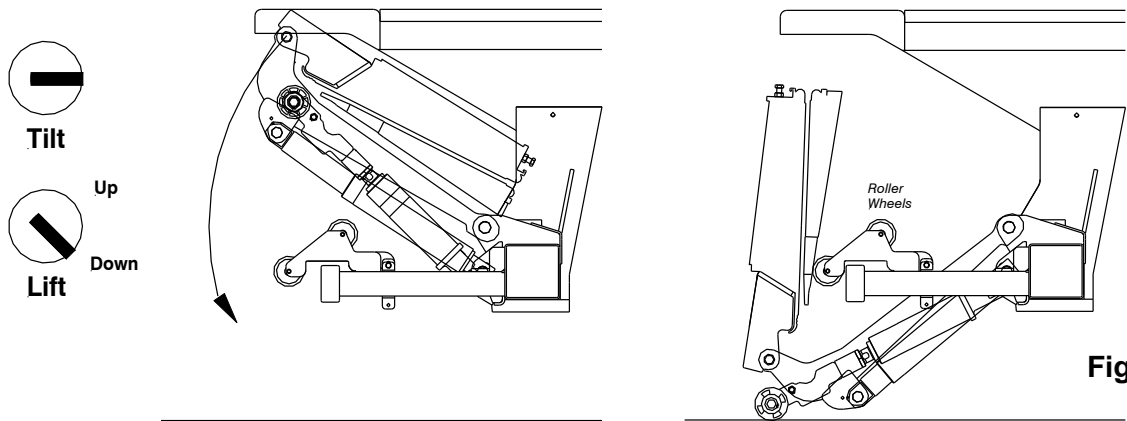


Fig. 4

2A. Manually pull the platform rearward away from the roller wheels, Fig. 5.

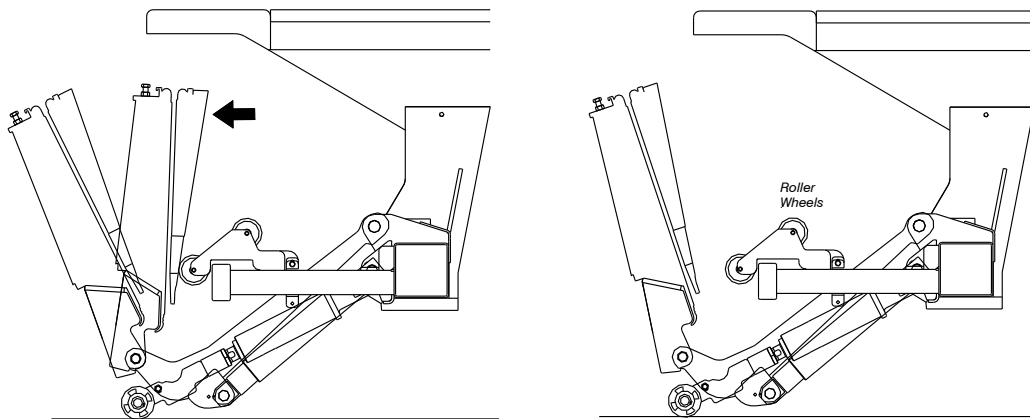
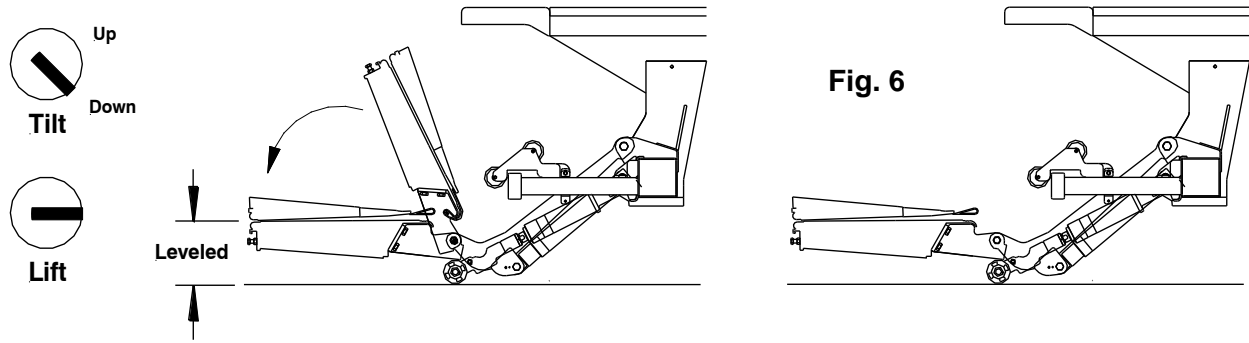
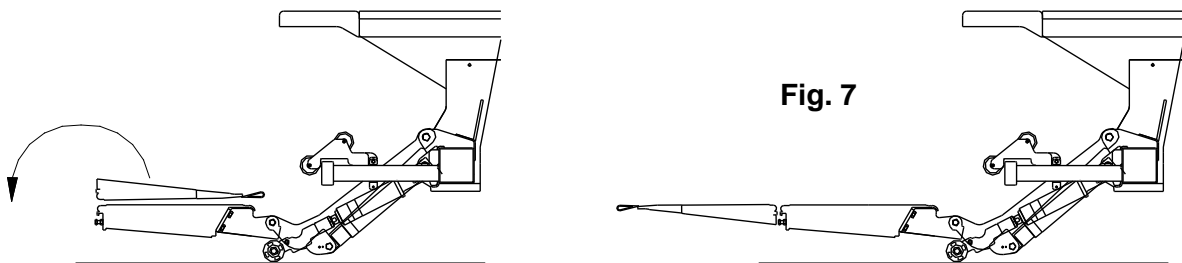


Fig.5

3A. Turn the Tilt switch Down until the platform is visually leveled, **Fig. 6**.

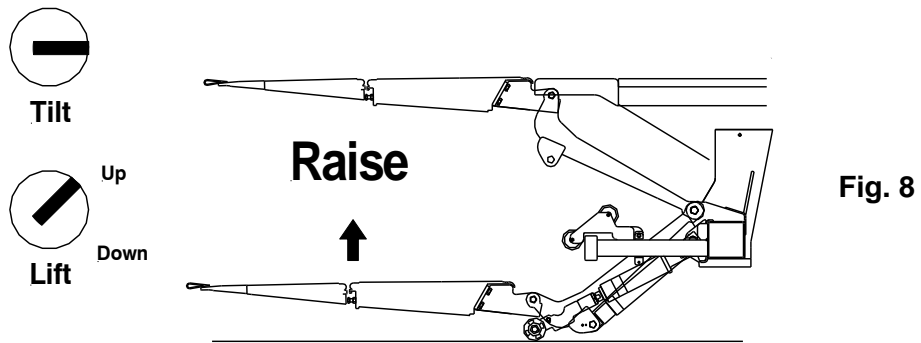


4A. Unhook the strap on the side of the platform main. Use the strap to manually unfold the platform tip, **Fig. 7**.

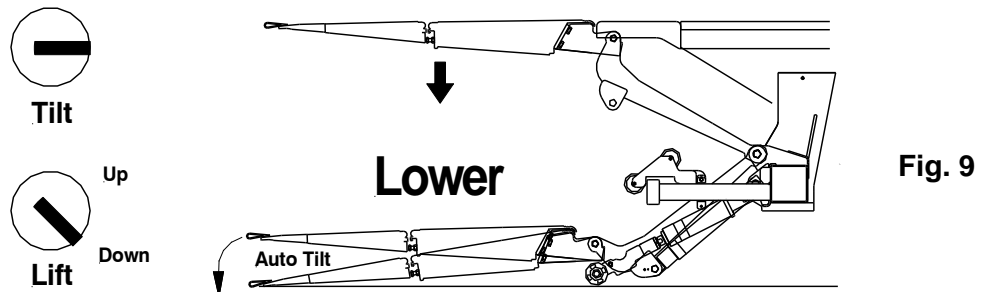


**To Unfold Platform - Follow Steps 1A-4A**

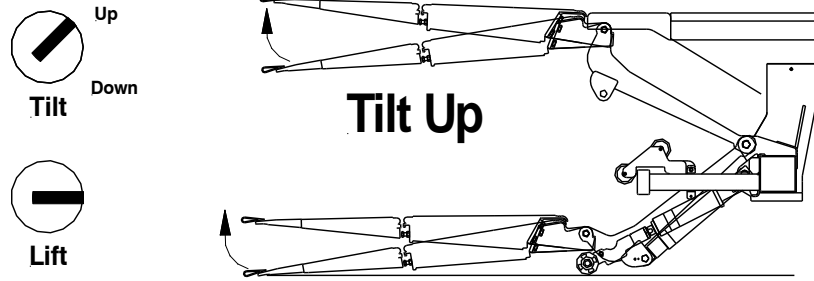
Turn the Lift switch Up to raise the platform to bed level. **Fig. 8**.



Turn the Lift switch Down to lower the platform to ground. Continue holding the Lift switch Down to activate auto tilt, **Fig. 9**.

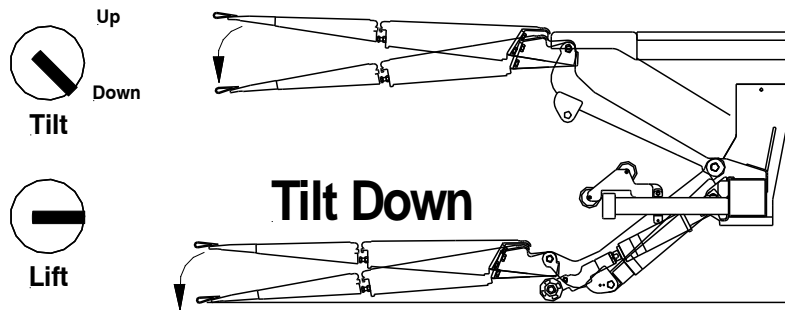


Turn the Tilt switch Up to tilt the platform up, **Fig. 10.**



**Fig. 10**

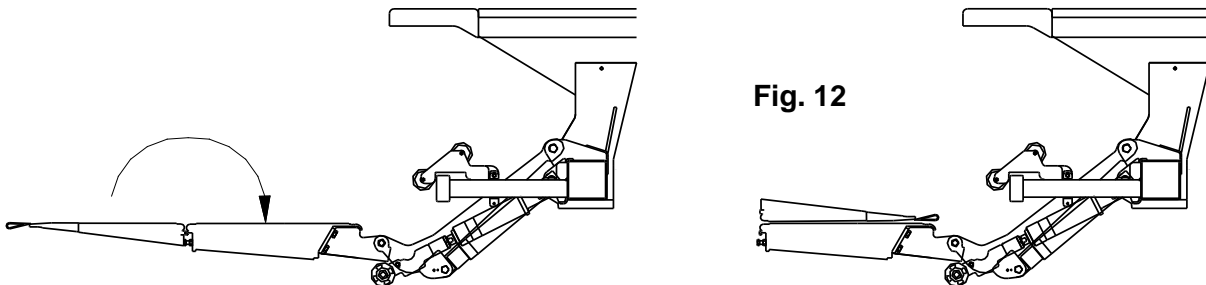
Turn the Tilt switch Down to tilt the platform down, **Fig. 11.**



**Fig. 11**

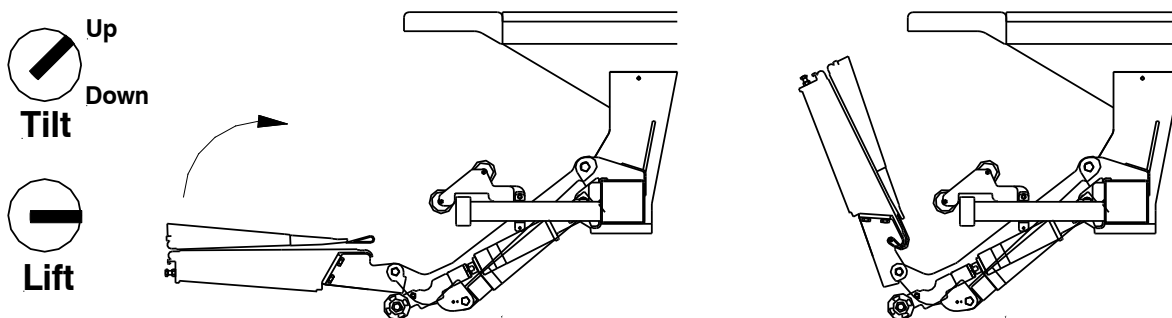
**To Store Platform - Follow Steps 1B-4B**

1B. Level the platform. Use the strap to manually close the platform tip. Secure the strap to the side of the platform main.



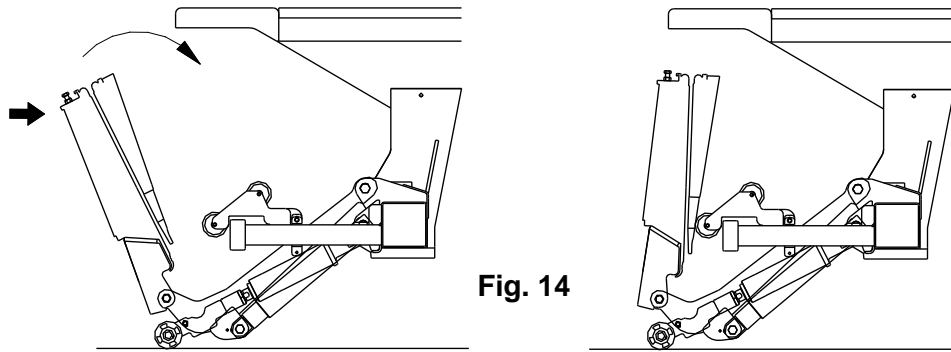
**Fig. 12**

2B. Turn the Tilt switch Up until the platform stops folding up.



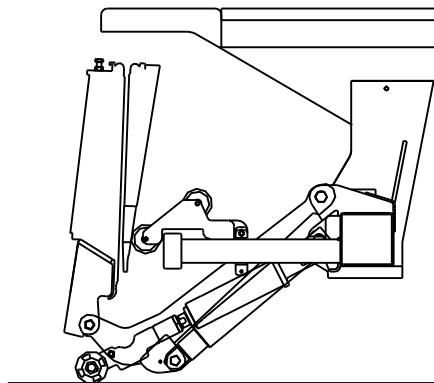
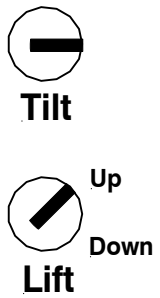
**Fig. 13**

3B. Manually push the platform forward onto the roller wheels, **Fig. 14**.

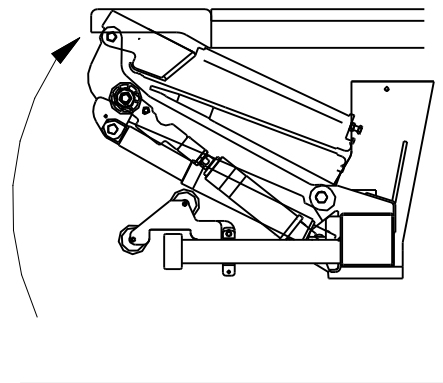


**Fig. 14**

4B. Turn the Lift switch Up until the stores automatically, **Fig. 15 & 16**. Turn OFF ON/OFF switch when liftgate is not in use.



**Fig. 15**



**Fig. 16**

### 6.2 Platform Cart Stops (Optional)

1. Push the cart stop latch out toward the curb side, **Fig. 17**. The cart stop will spring open automatically once the latch has been moved from its original position, **Fig. 18**.
2. To close the cart stops, push the cart stop latch inward towards the street side, **Fig. 19**. After the latch is in place close each cart stop by pushing each stop.

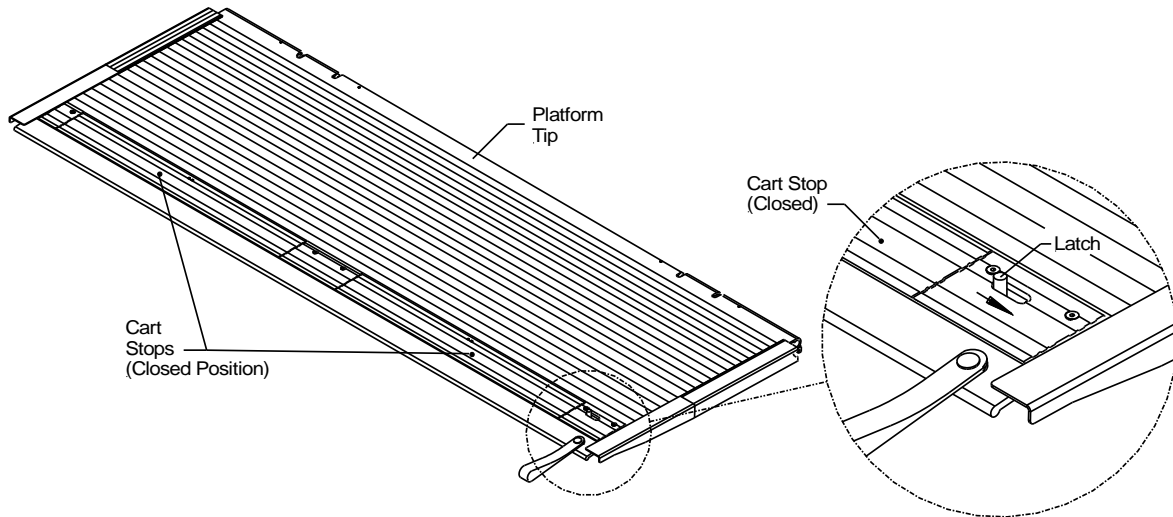


Fig. 17

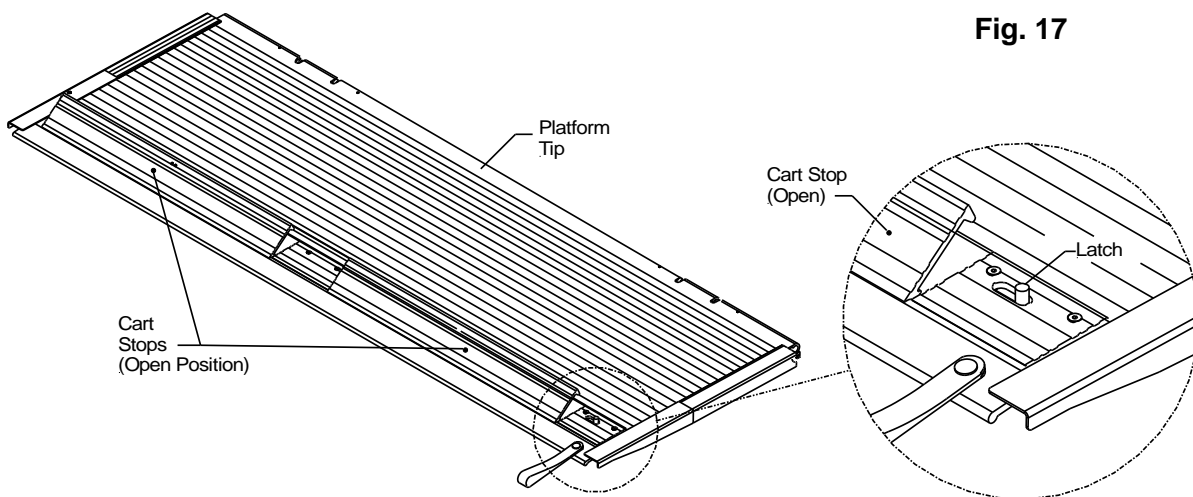


Fig. 18

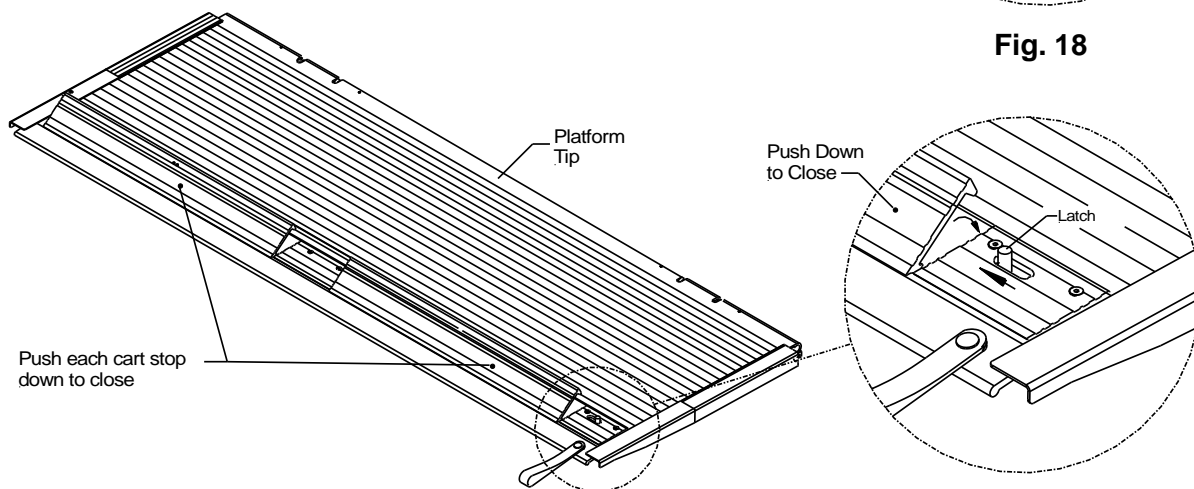


Fig. 19

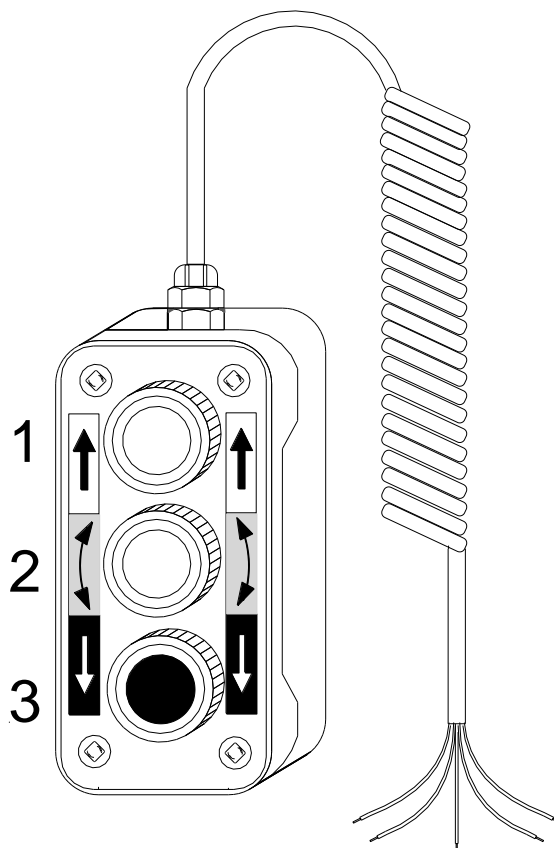


### 6.3 3-Button Hand Held Remote Control

- A. LOWERING DOWN:  
Push and hold button number **3**
- B. LIFTING UP:  
Push and hold button number **1**

Tilt functions: Push and hold button number **2** while lifting or lowering

- A. TILT DOWN:  
Push and hold button **2** and **3** simultaneously
- B. TILT UP:  
Push and hold button **2** and **1** simultaneously



**REPAIR OR REPLACE IMMEDIATELY FAULTY PARTS**

### 6.4 Operation by Foot Control (Optional)

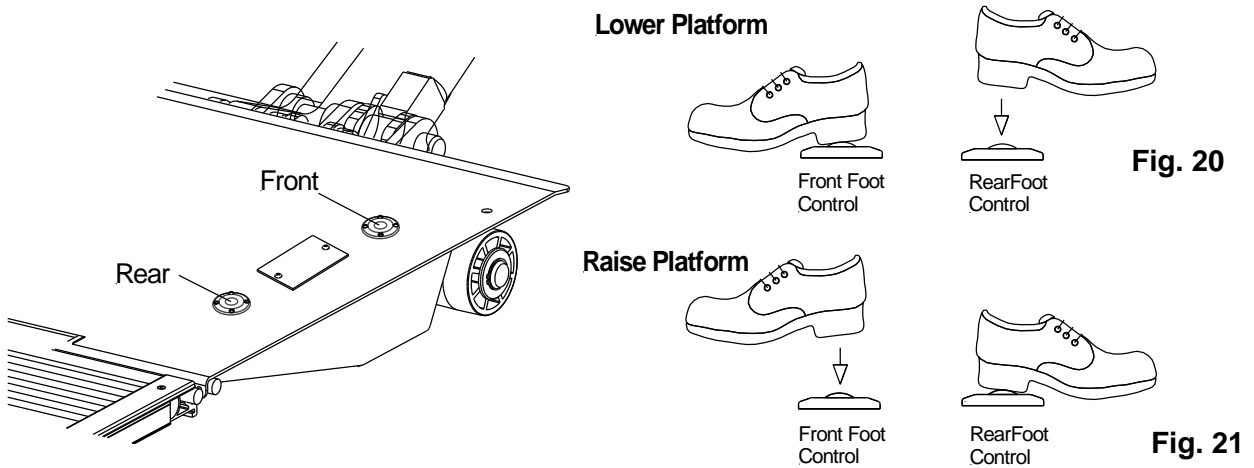
#### Lower Platform:

Step on the front foot control and hold, wait three seconds before stepping on the rear foot control, **Fig. 20**.

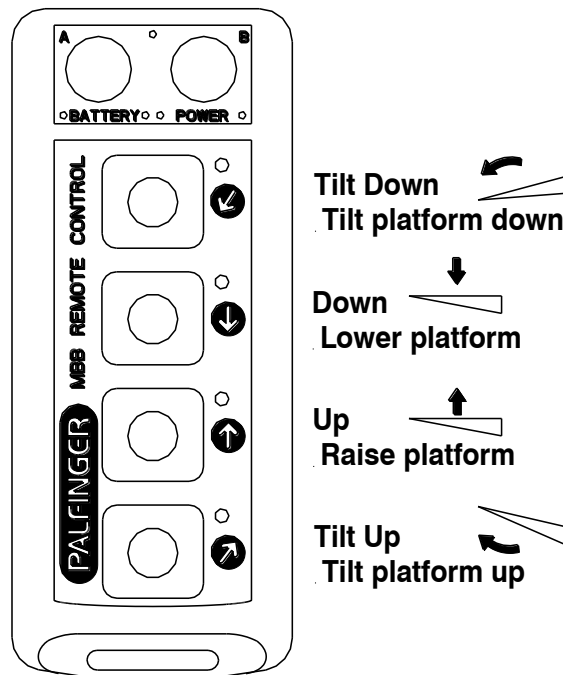
#### Raise Platform:

Step on the rear foot control and hold, wait three seconds before stepping on the front foot control, **Fig. 21**.

*If the platform is not responding to the controls within three seconds, repeat steps above.*

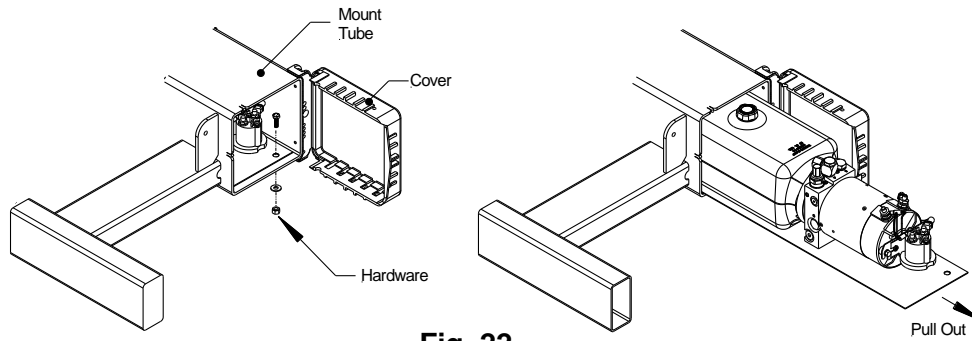


### 6.5 Operation by Wireless Hand Held Remote (Optional)



## 7 Preventive Maintenance and Quick Check

The ILF needs preventive maintenance to perform at its fullest capability. Lubricate and inspect regularly. Also, check on hoses, cables, controls, etc. and make sure these components are not damaged. To access the hydraulic power pack, remove the plastic cover on the curb side of the mount tube. Loosen and remove the hardware securing the power pack tray to the mount tube, **Fig. 22**.



**Fig. 22**

### 7.1 Maintenance and Care

The following “inspection and maintenance” should be performed at the recommended intervals depending on operation and amount of cycles or at the time when the unit shows any signs of damage or abuse. In order to prolong the liftgates longevity it is important to maintain and perform preventive care as indicated below. **Attention: Repair or replace faulty parts immediately.**

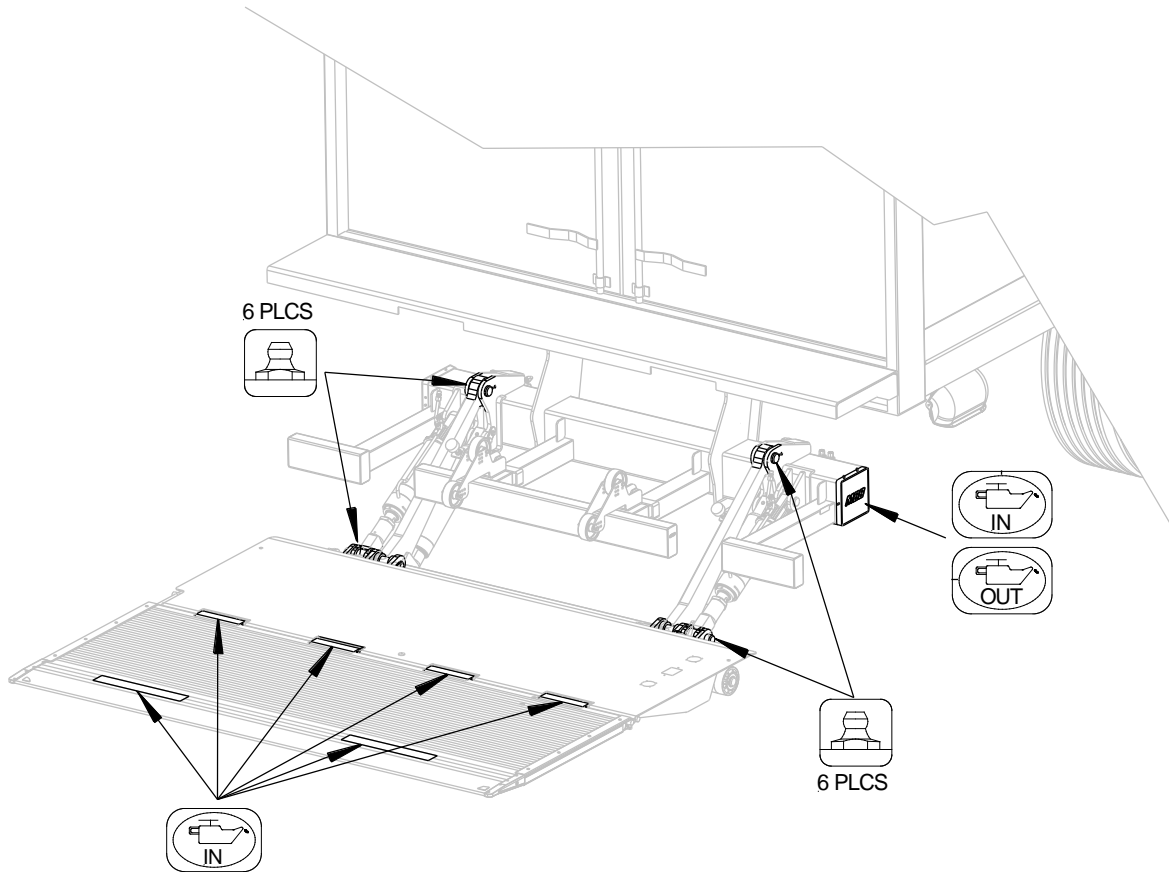
* Recommended bases for inspection and maintenance	Depending on use	Daily	Monthly	Quarterly
Cleaning	X			
General lubrication of pins and bushings				X
Oil level inspection				X
Oil change	X			
Check hydraulic hoses and pipes for leaks				X
Check controls and connections				X
Check pins and pin retaining bolts			X	
Check batteries and connections				X
Check warning labels and other safety equipment for effectiveness and visibility		X		
Visual check for loose or missing parts and un-usual noise during operation		X		
Check lock bolts and pins for tightness				X
Check complete function of gate		X		
Check mounting brackets of lift gate to frame for cracks or damage visually		X		

*Maintenance Schedule*

## 7.2 Lubrication

Properly lubricated, the ILF series INTERLIFT Liftgate will ensure longevity. Therefore, lubricate the liftgate at the same time as the truck/trailer. Grease more frequently if the liftgate is heavily used. The liftgate should be greased every 1200 cycles (depending on use – estimated every 3 month).

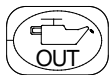
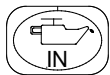
Check the oil level in the tank. The level should be between the two marks 5 and 7 when the platform is tilted down at ground level. Use a good quality of hydraulic fluid, ISO 32. Change oil at least once a year, preferably in the fall before the weather gets cold. The operation of the liftgate will accumulate condensation and some dirt which can interfere with the liftgate functions.



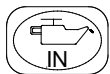
*Lubrication Points*



Zerk Fitting – 12 places, (3 in the mount frame, 3 in the cylinder/platform area).



Oil level in the power pack tank (see marking inside of power pack reservoir).

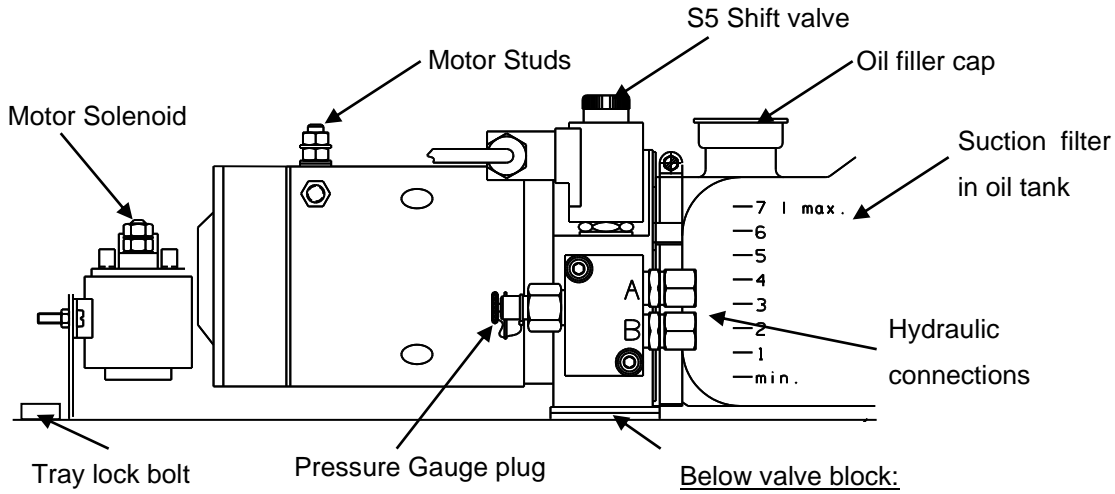


Platform hinges and optional Cart Stops (use WD-40 spray for lubrication).

### 7.3 Checking and Changing Oil

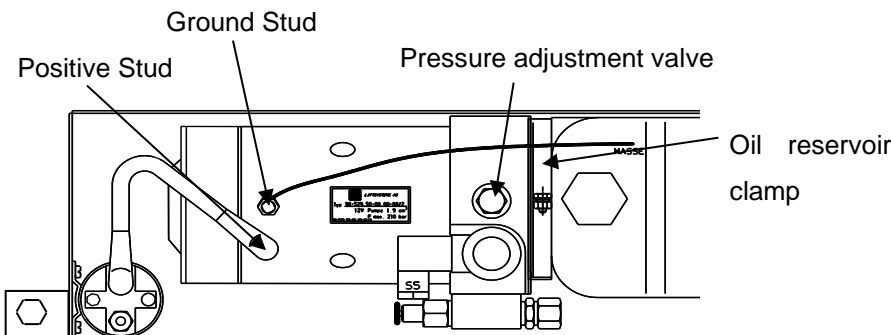
Check the quality of hydraulic fluid. If bad, take the following steps to change the oil.

1. Lower gate to ground and tilt platform down. The Power Pack Unit is stored inside the gates mount tube. Remove the plastic cover at the end of the tube. Locate the Tray Lock Bolt and remove it.
2. Pull the power pack out till you can reach the oil filler cap, **Fig. 23**.
3. Unscrew the oil drainage bolt (bottom of tray) and let the fluid drain out of the reservoir into an approved container, **Fig. 24**. When the reservoir is empty fill it up with hydraulic oil.



**Fig. 23**

Below valve block:  
Oil drainage screw 6mm hexagon socket



**Fig. 24**

DIAGRAM NO. 8  
HYDRAULIC UNIT

**Power Pack (Side and Top View) and Oil Drainage Screw (Bottom View)**

#### 7.3.1 Recommended Hydraulic Fluids

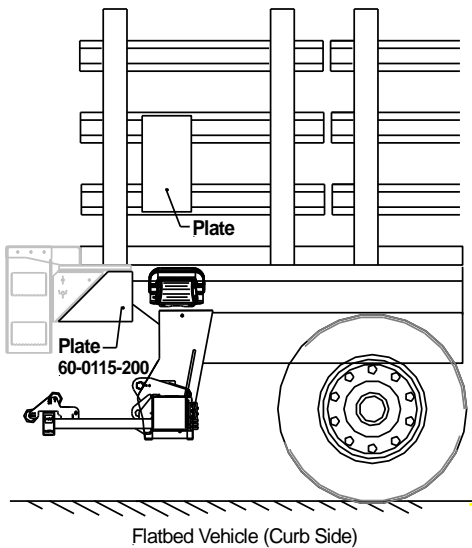
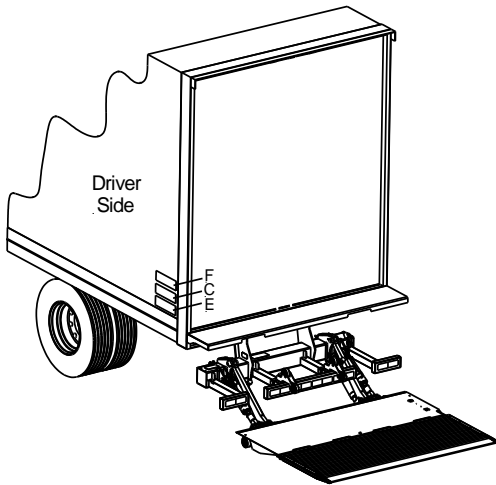
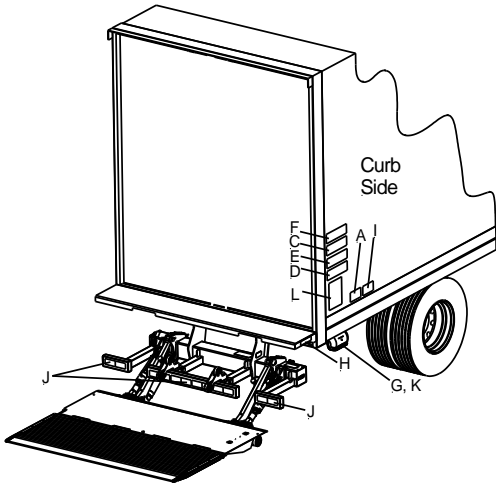
<u>TEMP. RANGE</u>	<u>BRAND</u>	
-10 TO 150 F	EXXON	UNIVIS J26
	MOBIL OIL	DTE 13M
	CHEVRON	AW MV32
	ROSEMEAD	MV 150 (32)
-50 TO 150 F	MOBIL	DTE 13M
	SHELL	AERO FLUID 4
<b>EXTREME COLD TEMPERATURE:</b>	<b>USE MILITARY SPEC:</b>	<b>MIL H5606</b>

## 7.4 Decal Placement and Inspection

For operator safety, all decals appearing in "Decal Kit" must be in a conspicuous place on control side of liftgate. This is typically a combination of decals on the liftgate and truck or trailer body. Please make sure to place the maximum capacity decal (C) on driver and curb side.

**Important: Never remove or paint over any decal. If any decals below require replacement contact INTERLIFT Liftgates.**

Decal Kit			
Decal	Qty.	Part No.	Description
A	1	ATG-URGWA	Urgent Warning: Elevating gate instructions
B	1	ATG-BKR	Circuit Breaker Reset (must be placed where the circuit breaker was installed)
C	2	ATG-XXXX	Capacity (please check the serial number plate to find out your specific capacity)
D	1	ATG-RESET	Circuit Breaker Protection
E	2	ATG-WLH	Warning: liftgate can crush
F	2	ATG-CTN	Caution: Always stand clear of platform area
G	1	ATG-CAB	Liftgate Shut-Off (Place Decal next to the On-Off Switch in the Cab)
H	1	ATG-WNG	Warning: Use handle to open (Must be located underneath handle (main section))
I	1	ATG-FT	Notice for Foot Control
J	Strip		Conspicuity Tape (Place tape along bumper)
K	1	ATG-ILF	Operating Instructions (Place in control box)
L	1	85-0816-000	Operating Instructions (Place on the curb side of vehicle body above control box)



**URGENT WARNING**

**BEFORE OPERATING LIFT, BE SURE YOU UNDERSTAND:**

1. Improper operation of this lift gate can result in serious personal injury. Do not operate unless you have been properly instructed, have read, and are familiar with, the operating instructions. If you do not have a copy of the instructions please obtain them from your employer, distributor or lessee, as appropriate, before you attempt to operate the lift gate.
2. Be certain the vehicle is properly and securely braked before using the liftgate.
3. Always inspect this lift gate for maintenance or damage before using it. If there are signs of improper maintenance, damage to vital part, or a slippery platform surface, do not use the lift gate. Do not attempt your own repairs, unless you are specifically trained.
4. Do not overload. See the Mfg. Literature and/or Rating Label on the unit for the rated load. Remember that this limit applies to both raising and lowering operations.
5. Each load should be placed in a stable position as near as possible to the center of the platform.
6. Never allow yourself, a helper, or a bystander to stand in a position where an unstable load might fall on them. Do not allow any part of your or your helper's body to be placed under, through, or around any portion of the moving lift gate, or in a position that would trap them between any parts when the lift gate is operated.
7. This lift gate is intended for loading and unloading of cargo only. Do not use this lift gate for anything but it's intended use. The lift gate is not equipped with a back up system to prevent falling in the event of a failure.

ATG-UNBRKLD

Decal - A

**CAUTION**

**Maximum Load Capacity**

**xxxx pounds.**

Center load on platform to avoid personal or property damage.

ATG-4000

Decal - C

**WARNING**

LIFTGATE HAZARDS CAN RESULT IN CRUSHING OR FALLING

KEEP HANDS AND FEET CLEAR OF PINCH POINTS

IF RIDING LIFTGATE, MAKE SURE LOAD IS STABLE AND FOOTING IS SOLID

READ AND UNDERSTAND ALL INSTRUCTIONS AND WARNINGS BEFORE USE.

Decal - E

**NOTICE**

LIFT GATE SHUT-OFF TO BE TURNED OFF WHEN LIFT IS NOT IN USE

ATG-CAB

Decal - G

**NOTICE**

**DOWN:** Step on switch 1 and hold - wait between one and three seconds before you step on switch 2.

**UP:** Step on switch 2 and hold - wait between one and three seconds before you step on switch 1. The platform will lift up to preset position before raising.

If both switches are not activated within three seconds start over.

ATG-PT

Decal - I

**OPERATING INSTRUCTIONS**

ILF 33/44/55

- To operate this liftgate read and understand the operating decals and manuals.
- Make certain the platform is clear before operating the liftgate.
- Liftgate shut-off switch must be turned off when liftgate is not in use.
- Keep platform in horizontal position when loading and unloading.
- Do not overload, refer to capacity decals.

For questions regarding operation call (888) 776-0664

Decal - K

**NOTICE**

ELECTRICAL SYSTEM PROTECTED BY RESETTABLE CIRCUIT BREAKER

TO RESET - PUSH RESET TAB IN

ATG-BKX

Decal - B

**NOTICE**

ELECTRICAL SYSTEM IS PROTECTED BY A RESETTABLE CIRCUIT BREAKER. SEE OWNER'S MANUAL AND DECAL LOCATED AT THE BATTERY.

ATG-RESET

Decal - D

**WARNING**

ALWAYS STAND CLEAR OF PLATFORM AREA

Decal - F

**WARNING**

USE HANDLE TO OPEN ALWAYS STAND CLEAR OF PLATFORM AREA WHEN OPERATING THIS GATE

ATG-MHG

Decal - H



Decal - J

**OPERATING INSTRUCTIONS**

Read all Decals and Manuals Before Operating the Liftgate

ILF 33/44/55

Select the proper OK, ONLY switch for lifting on an unbraked vehicle and the truck's wheels will be inside the safe.

Decal - L

## 7.5 Quick Check List

1. Operate the liftgate throughout its entire operation and check for noise and damage such as bent parts or cracked welds.
2. Inspect all welds and fasteners that attach the mount frame to the truck. All pins and bolts that connect the lift arm to the mount frame and to the platform.
3. Visually inspect the hydraulic lines for damage, scratches, bending or leakage.
4. Inspect the cylinders for leakage and that the cylinder pins are secured with lock bolts.
5. Check the oil level when the platform is down at ground level. The level should fall between the upper markings 5 and 7 on the tank. We recommend replacing oil after the first 1200 cycles, after that on a yearly basis in the fall before winter begins.
6. Check for oil leakage around the power pack and inside mount tube. Tighten or replace components if needed. If you perform work on any hydraulic components bleed the air out of the system by operating all functions several times.
7. Check all electrical connections. Clean and protect battery terminals and check for tightness.
8. Inspect all the terminals on the solenoid-operated valves at the port of the cylinder. Lubricate the terminals for better protection from oxidation if needed.
9. Grease all zerks on the lift gate and make sure they all take grease. Sometimes it helps to operate the liftgate while you do this.
10. Test all the lift gate functions.
11. Check the function of the pressure relief valve.
12. When doing daily checks and you find any kind of damage that can make the use of the liftgate dangerous, it must be repaired before using. All repairs should be made by an authorized technician. Use only original spare parts. If in doubt contact your INTERLIFT Liftgates distributor or call INTERLIFT Liftgates directly.



**Do not cover up any accidents or damage; it can be dangerous for you and your co-workers.**



## 8 Troubleshooting

### ATTENTION:



**Please check the following points before identifying any faults.**



Serious injuries are possible from tools short circuiting main battery connections. Do not leave tools or other equipment that may cause shorts around the battery.



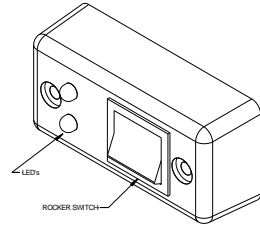
Every time you are finished troubleshooting, close the rubber cover on the curbside of the mount frame. **REINSTALL THE PLASTIC STRAP ON THE RUBBER COVER WHEN FINISHED.**

- Please change oil after working on hydraulic unit (removal of valves, opening of cylinder etc.)
- There is a possibility of injury if somebody other than an authorized technician works on the electrical system.
- Injuries are possible if short circuits are caused by tools on the main battery connections.

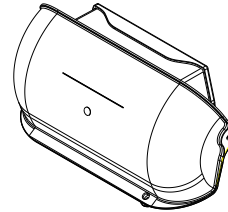
## 8.1 Liftgate will not power on.

### 1. Check the cab shut off switch.

Turn on cab switch, located in the cab next to the steering wheel. Location may vary by model and year of truck. Switch has L.E.D. lights: they should stay on continuously. On trailer units, you will find the switch on the control box to activate the gate, **Fig. 25**.



*In Cab ON/OFF Switch*



*ON/OFF Switch (Trailer)*

**Fig. 25**

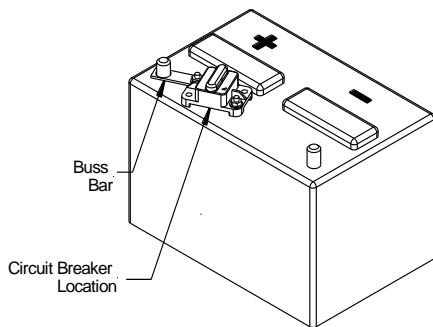
### 2. Check the circuit breaker at the main batteries.

Every truck has a circuit breaker on top of the main battery or if you have a studio unit, or a trailer, you will also find an auxiliary battery kit as shown in the illustration below, **Fig. 26**.

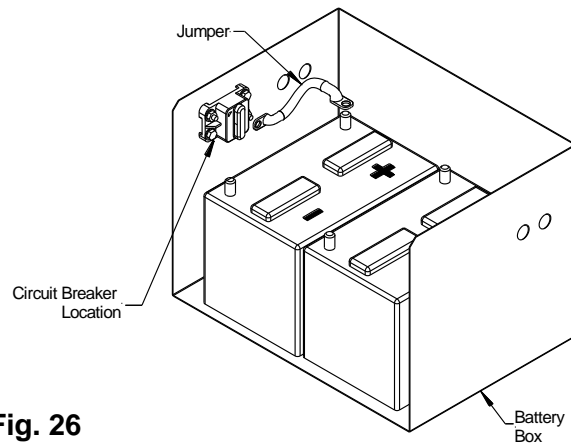
If circuit breaker reset tab is exposed, push it back in as shown on the decal ATG-BKR next to the circuit breaker or on battery box lid, **Fig. 27**.

Battery Mount

Battery Box Mount

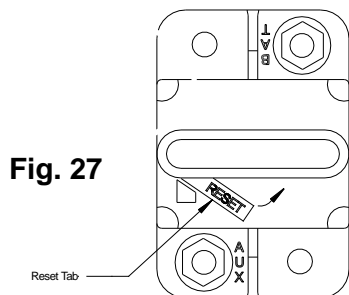


*Truck Battery*

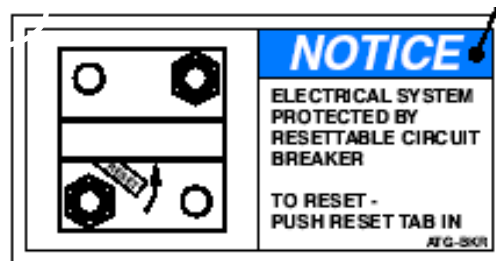


*"Auxiliary Battery"*

**Fig. 26**



**Fig. 27**



***Circuit Breaker Needs to be Reset when Reset tab is exposed***

### 3. Are the vehicle batteries charged?

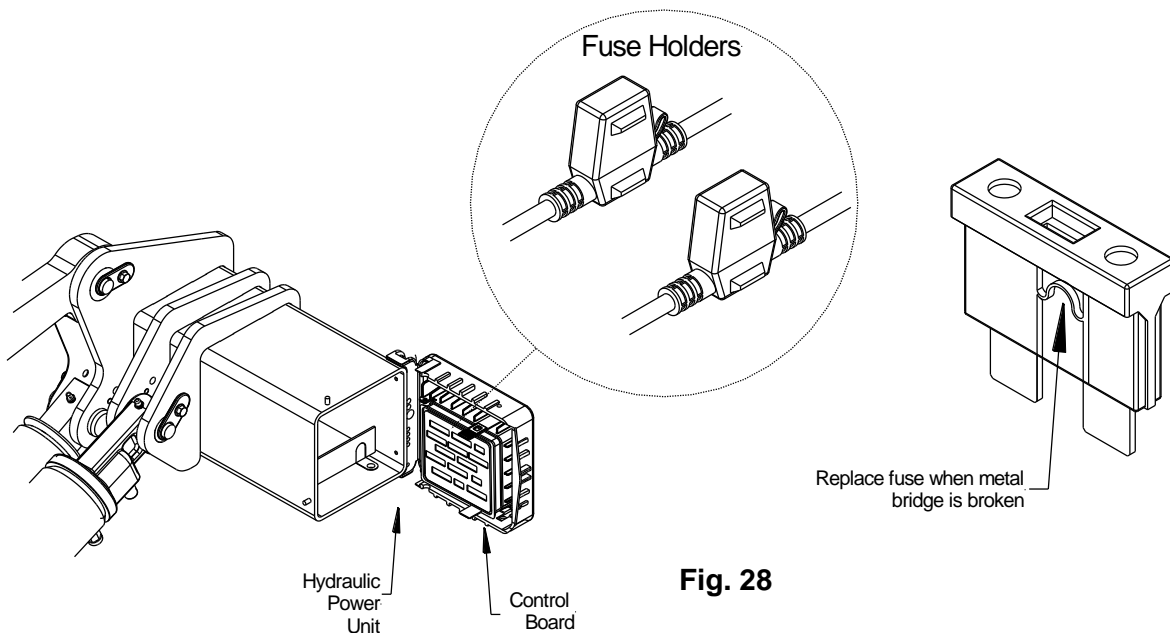
Check batteries and the truck/trailer charging system. Start truck and run engine in fast idle for charging the batteries. If liftgate starts working, recharge batteries.

### 4. Check the fuse at the power pack and battery.

The control board has two 15 Amp fuses and at the battery there should be a 20 Amp fuse. Check all fuse holders for blown fuse(s) and replace each blown fuse with the same amperage, **Fig. 28**.



**DO NOT use higher amperage fuse.**



**Fig. 28**

### 5. Is the connection to ground in power pack OK?

Is the ground connection from the tail lift to vehicle OK?

### 6. Check the oil level in the power pack reservoir.

The Hydraulic Power Unit is located inside the mount tube. To access the oil reservoir, remove the screw and slide out the Power Unit until there's access to the oil reservoir. Check the oil level is between the 5 and 7 marks.

### 7. Are there any damages on mechanical or electrical parts (such as damaged cables)?

Perform a visual inspection of all electrical wiring and mechanical components.

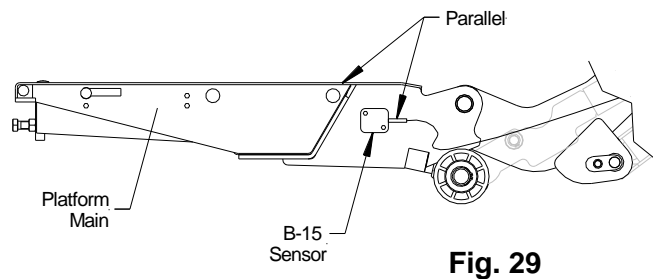
## 8.2 On-Off L.E.D.s are on but all functions are dead

Possible malfunctions:

1. Short in hand held remote or its wire, unplug hand held control at J31. Remove J1 plug for 5 seconds. Reinstall J1, try main control board switches. If gate operates the problem is in the hand held control or its wiring.
2. Short in control box wire remove J30 plug. Remove J1 plug for 5 seconds. Reinstall J1, try hand held remote. If gate operates the problem is in the control box switches or harness.  
After disconnecting plugs – reboot board by unplugging J-1 for 5 seconds and plug it back.

## 8.3 L.E.D.s continue to stay on, after switch is turned off

- B-15 is not working.  
Make sure, the wire strain relief is always parallel with top of the platform, **Fig. 29**.



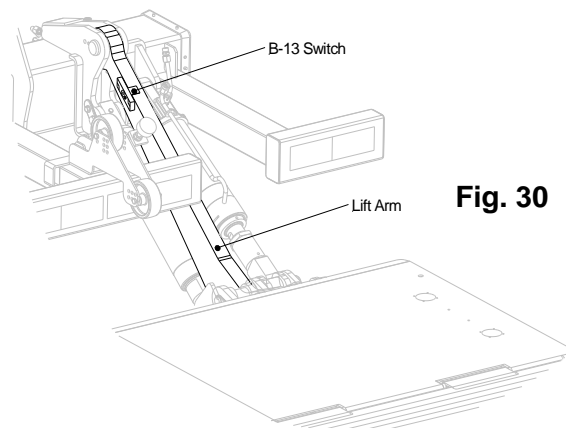
**Fig. 29**

## 8.4 Platform tilts down before it reaches the ground

- Adjust B-13 lift arm switch.
- B-13 is not working → unplug J-41 (gate operates without sensor but loses auto-tilt).

The B-13 switch is located on the inside part of the lift arm on the curb side, **Fig. 30**.

- Set the switch in a horizontal level when the platform is 12"-15" off the ground.

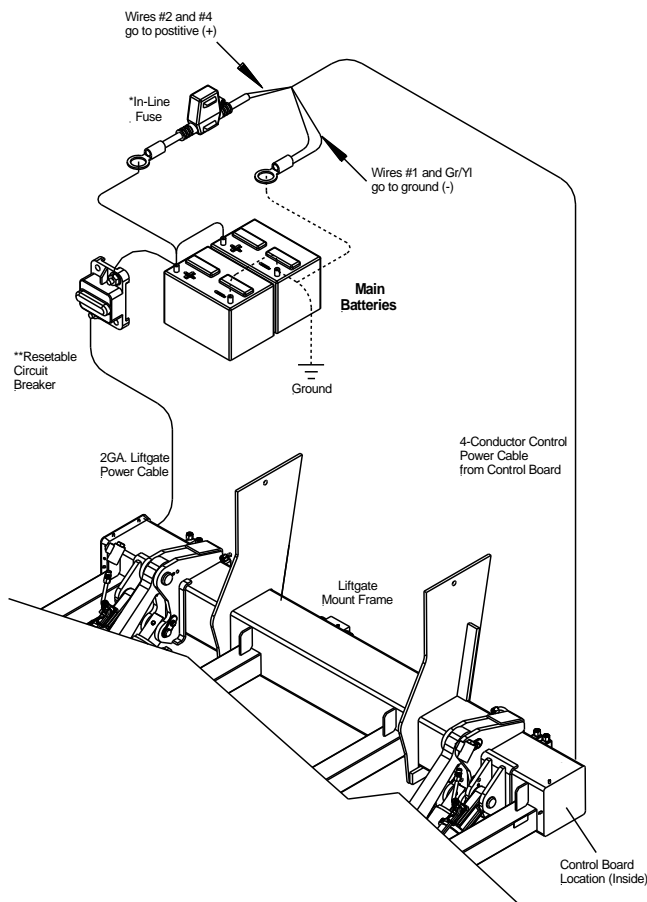


**Fig. 30**

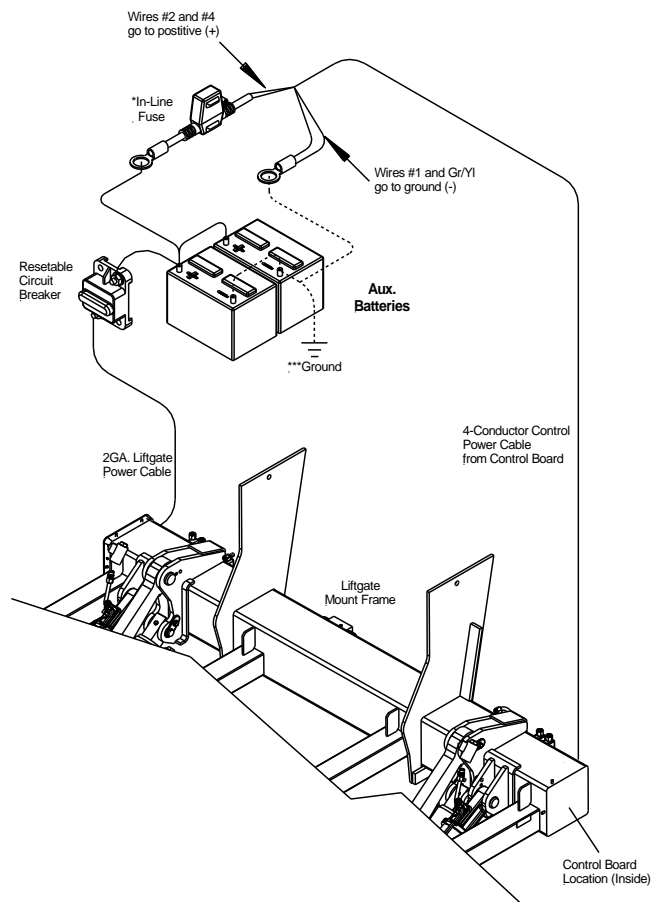


If gate is still not working, take truck/trailer to a repair station.

## 8.5 Main Power Connections



**Battery Wiring Setup – Truck**



**Battery Wiring Setup - Trailer**

\*In-Line ATC Fuse: 20 Amp. **Replace with same amperage fuse when necessary.**

\*\*Resettable Circuit Breaker: 150 Amp Min. **Replace with same amperage breaker when necessary.**

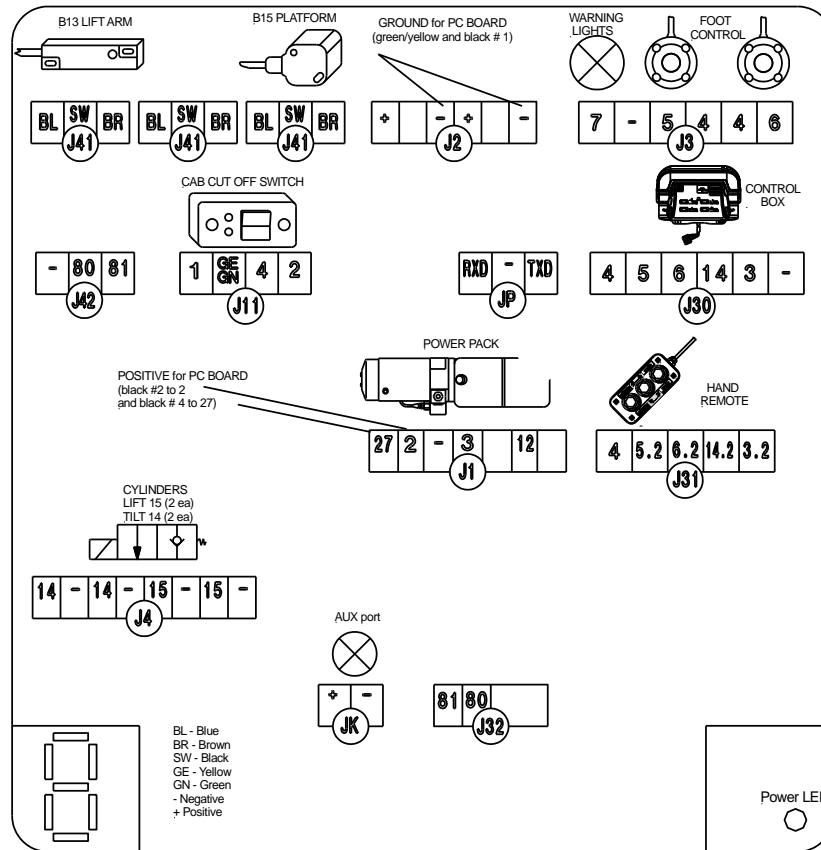
\*\*\*Ground: For optimal grounding, ground all batteries and power units to the body side rails of the vehicle.

**NOTICE: DO NOT attempt to jump in-line fuses with other objects other than the specified fuse.**

**Do not increase the amperage rating of fuse. Serious harm to the liftgate will result when standard practices are not followed.**



## 8.7 Control Board Connector Overview



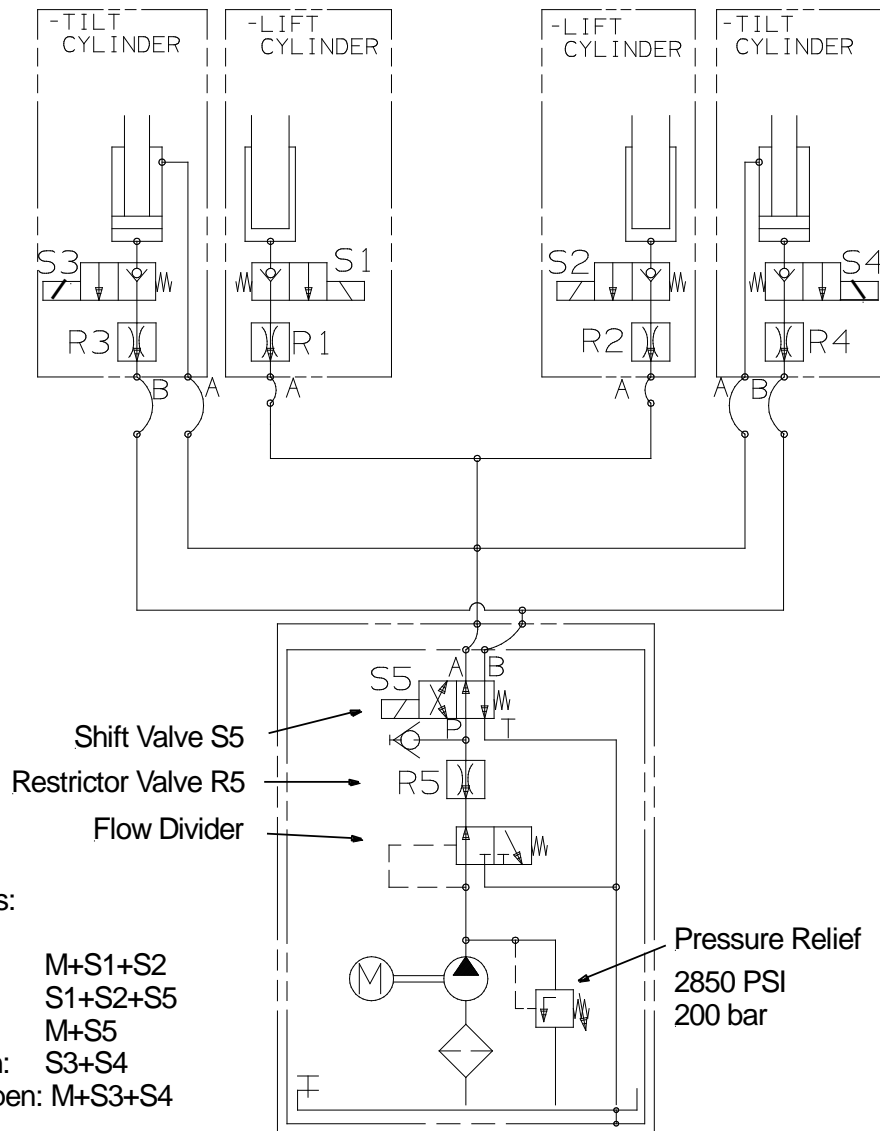
Control Board Codes:

Code	Description	Reset
0	System ok / Cab switch off, (or missing bridge J11/2<->4)	
1	System ok / Cab switch on, (or bridge J11/2<->4)	
2	Low Voltage	Cab switch: off/on (or disconnect bridge J11/2<->4)
3	Missing tilt switch B-13 at lift arm or defective.	Automatically when the valves are back to normal
4	Missing tilt angle sensor B-15 at lift platform or defective	Automatically when the valves are back to normal
5	Missing tilt angle sensor B-15 at platform or defective	Automatically when the valves are back to normal
6	Warning lights shorted	Cab switch: off/on (or disconnect bridge J11/2<->4) or close tail lift
7	Short in cab switch/on-off switch or aux port	Cab switch: off/on (or disconnect bridge J11/2<->4) or close tail lift
8	General short in electrical wiring	Cab switch: off/on (or disconnect bridge J11/2<->4) or voltage interruption MBB control
9	Defect at motor solenoid detected during lifting	Automatically when the valves are back to normal
A	Voltage V02 (J1 pin 2) is missing, defective fuse	Replace the fuse
B	Defect at opening, valve (S3/S4) or motor relay detected during opening	Automatically when the valves are back to normal
C	S5 valve detected during closing or motor solenoid defective	Automatically when the valves are back to normal
D	S5 valve detected or defect at lowering valve (S1/S2)	Automatically when the valves are back to normal
E	Emergency program (all sensors are bypassed). Activation by: Press Open+Lower>10 seconds	Cab switch: off/on (or disconnect bridge J11/2<->4)
F	Diagnosis mode activated	Removing service connector

### 8.8 Hydraulic Schematic

Functions:

- S1 and S2 = Release Valve for lowering function
- S3 and S4 = Release Valve for tilt down function
- R1 and R2 = Flow Restrictor located inside hose adaptor on lift cylinder
- R3 and R4 = Flow Restrictor located inside hose adaptor on tilt cylinder
- S5 = Shift Valve is activated on tilt up and lowering function
- R5 = Restrictor Valve located in power pack
- Flow Divider is activated, when fluid is going back into the power pack
- If Flow Divider is loose or hanging up the fluid is circulated back in to tank



Functions:

- Lift: M+S1+S2
- Lower: S1+S2+S5
- Tilt Up: M+S5
- Tilt Down: S3+S4
- Horiz. Open: M+S3+S4

**Hydraulic Schematic**  
4 cylinder gate (2 lift & 2 tilt cylinder)





## 9 Needed Information for Ordering Spare Parts and Repairs

### 9.1 Ordering Spare Parts

In order to assure quick delivery of spare parts, please always state the following information when making orders:

1. Liftgate model & serial number.
2. Designation and number of the spare part in accordance with the spare parts list.
3. Designation and number marked on the individual component (if available).

### 9.2 Repairs

Parts sent to INTERLIFT Liftgates to repair must be accompanied by a letter (in separate cover) giving details and scope of the repairs required.

## 10 Warranty

INTERLIFT Liftgates provides warranty as part of its conditions of delivery.

Spare part deliveries are first of all billed. INTERLIFT Liftgates then issues credit for all or part of the invoiced sum when INTERLIFT Liftgates has been able to determine that the warranty claim is justified as defined by its warranty conditions. INTERLIFT Liftgates does this by inspecting the defected parts which are sent back to INTERLIFT Liftgates freight-prepaid as well as the written description of the problem which must have been filled out in full.

The parts that are sent back to INTERLIFT Liftgates, marked with serial number and address, become INTERLIFT Liftgates' property if the warranty claim is accepted.

All warranty claims must be received **within 30 days** of repair or replacement. Including the following information:

1. Liftgate model.
2. Liftgate serial number.
3. Description of problem.
4. Itemized bill of repair with breakdown of number of hours to perform warranty work and labor changes per repair.
5. Parts used for repair with INTERLIFT Liftgates part number.
6. RMA#.
7. Contact at INTERLIFT Liftgates, if applicable.

Model	Pump and Motor	Cylinders	Hardware	Control System	Hydraulic
ILF Auto Fold	2 yr	2 yr	2 yr	2 yr	2 yr

*Warranty Coverage Schedule<sup>1</sup>*

<sup>1</sup> Effective: Aug. 2010

**11 Contact Address**

15939 Piuma Ave  
Cerritos, CA 90703  
Phone: (562)-924-8218  
Fax: (562)-924-8318

E-mail (parts order):  
[liftgateparts@palfinger.com](mailto:liftgateparts@palfinger.com)

E-mail (technical support):  
[technicalapplications@palfinger.com](mailto:technicalapplications@palfinger.com)



572 Whitehead Road  
Trenton, NJ 08619  
Phone: (609)-587-4200  
Fax: (609)-587-4201

E-mail (parts order):  
[liftgateparts@palfinger.com](mailto:liftgateparts@palfinger.com)

E-mail (technical support):  
[technicalapplications@palfinger.com](mailto:technicalapplications@palfinger.com)