

INTERLIFT

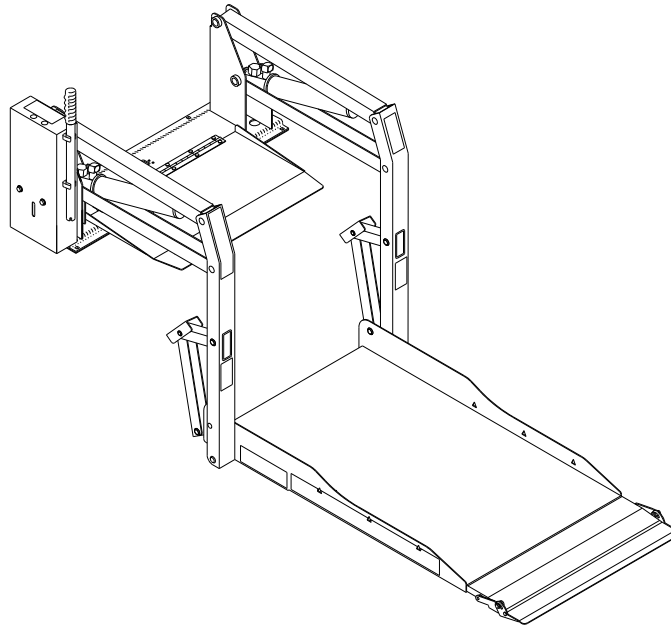

INSTALLATION MANUAL

CITYFIX, 1100 lbs. Capacity



CITYFIX 1100 Installation Manual
ECN-M1723, Rev. 1.2, 01-19-24
Copyright © 2023 Palfinger Interlift, LLC.
All rights reserved.

Information in this document is subject to change without notice.
Visit www.palfinger.com for up to date information and notifications.

If you received this product with damaged or missing parts,
contact INTERLIFT Liftgates at (888)-774-5844

Parts Order/Inquiries
liftgateparts@palfinger.com

Technical Support
technicalapplications@palfinger.com



15939 Piuma Ave.
Cerritos, CA 90703
Tel (888) 774-5844
Fax (562) 924-8318



572 Whitehead Road.
Trenton, NJ 08619
Tel (609) 587-4200
Fax (609) 587-4201

Table of Contents

1 LIFT LOCATION 4

2 LIFT INSTALLATION GUIDELINES 4

3 LIFT MECHANICAL INSTALLATION 5

4 ELECTRICAL INSTALLATION..... 6

A. INSTALL MAIN CIRCUIT BREAKER..... 7

B. ROUTE AND CONNECT MAIN POWER CABLE..... 7

C. GROUND CONNECTIONS..... 9

D. INTERLOCK INSTALLATION 10

E. LIMIT SWITCH ADJUSTMENT 12

5 VERIFY INSTALLATION 14

Company Information:

Company Name: _____

Advisor Name: _____

Vehicle Year Make & Model: _____

Liftgate Information:

Liftgate Serial Number: _____

Liftgate Model Number: _____

Date of Purchase: _____

Date of Installation: _____

Thank you for choosing INTERLIFT Liftgates.

1 LIFT LOCATION

The installation surface must be flat and level. It is recommended that lift be installed on a 12mm, minimum, high grade plywood sub-floor. However, this additional installation height may not be acceptable in cases where overhead clearance is limited.

NOTE: Check for proper travel clearance through doorway.

- With doors fully open, place/position lift in vehicle doorway as close as possible to door, with lift's baseplate assembly parallel to side of vehicle.
- Allow a distance of 20mm, if possible, between door and the part of lift closest to it. Adjust lift left and right-side locations to accommodate subframe members.
- Verify proper clearance of door frame, passenger seats, and outer edge of vehicle floor and possible interference with wires, fluid lines, subframe members, etc.

2 LIFT INSTALLATION GUIDELINES

The mounting of lift is a very important step. Lift performance can be adversely affected by improper mounting or fastening of lift. Although fastening details may vary from one vehicle to the next, some general principles apply:

- Be certain that all mounting bolts are properly installed and tightened. Bolts used to fasten baseplate assembly to vehicle floor must have a minimum strength rating of SAE Grade 5 and be torqued to 38 Nm, dry. Recognize that the most important bolts are those along the rear of lift, since these bolts retain majority of load.
- Refer to Diagram 1. Improper torquing sequence of bolts may result in a warped or bowed baseplate, which can cause lift to operate erratically.

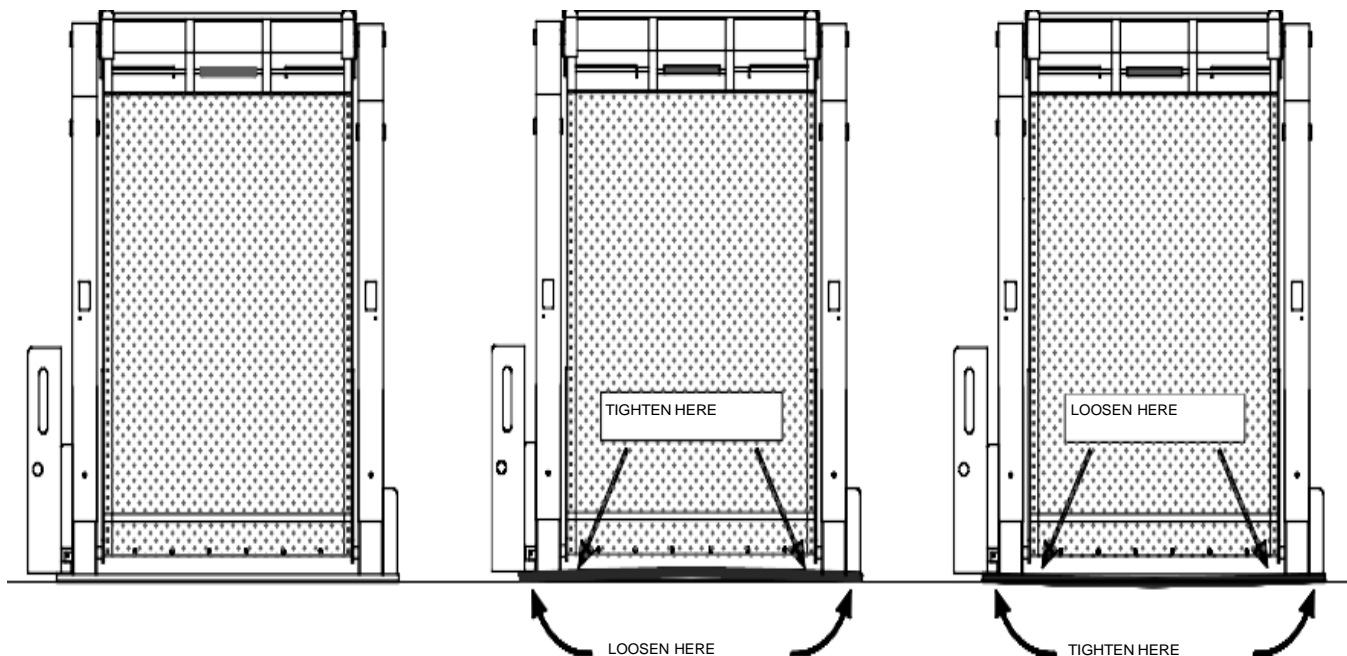

Diagram No. 1

3 LIFT MECHANICAL INSTALLATION

Refer to Diagrams no. 2 and 3. Clamping bars are used to help distribute floor loading and should only be shortened if necessary to clear a subframe member. A subframe member should be used to support forward end of clamping bar.



WARNING!

Lift weight is approximately 160-170 kgs. Take great care when positioning because the lift might tip. This procedure should not be attempted by one person.

- a. Refer to Diagram no. 2. With rear doors fully open, position lift in opening so that front and rear edges are supported by vehicle floor. Position folded lift in doorway with lift baseplate parallel to side of bus and lift clearing the doors by at least 6mm.
- b. Refer to Diagram no. 3 on next page. Mark and drill eight 10mm baseplate mounting holes (1 thru 8) through vehicle floor.

NOTE: Before drilling holes, be sure that underlying wires, fuel and hydraulic lines, etc, are not in the way.

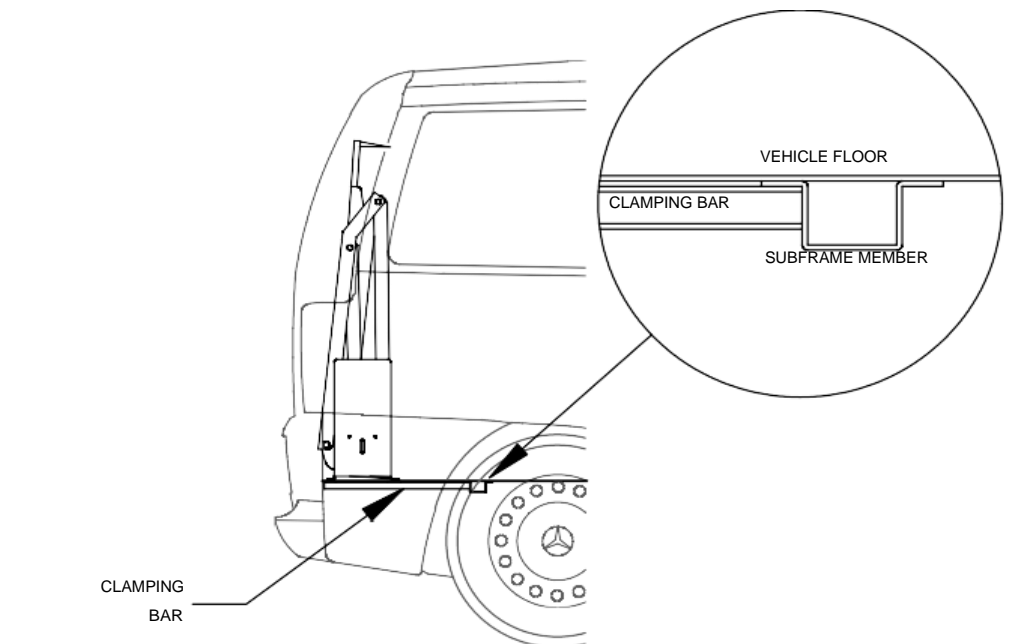
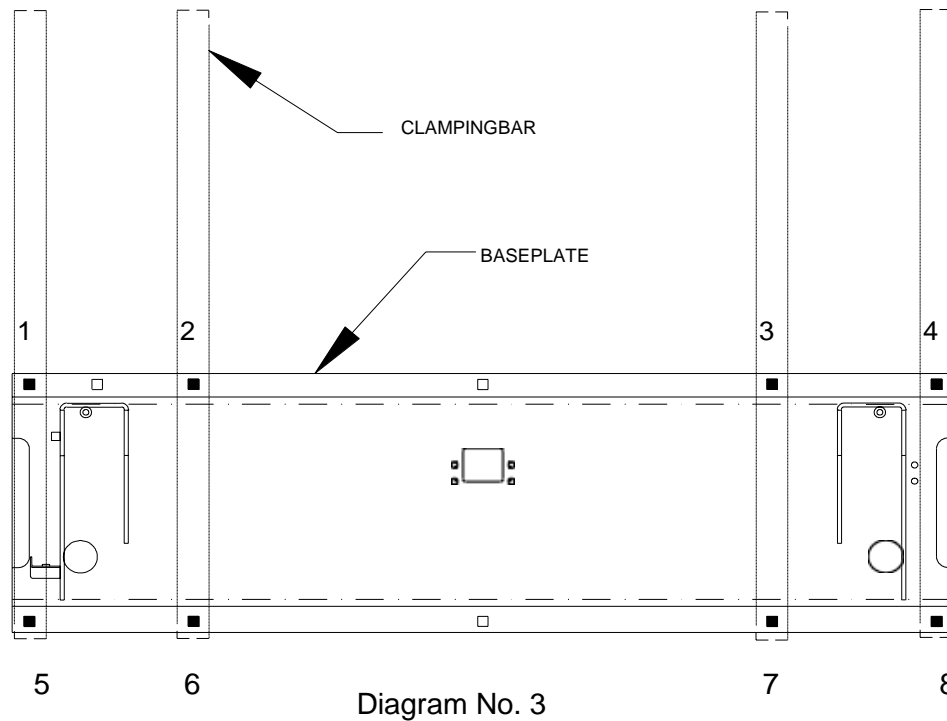

Diagram No. 2

- c. Insert eight 3/8-16 x 4" carriage bolts through baseplate and vehicle floor.
- d. Place four clamping bars below floor. The clamping bars are bolted across the baseplate width, i.e., from 1 to 5, 2 to 6, etc., and run towards front of van. Secure with 3/8" washers, lock washers and hex-nuts.



- e. Verify that lift baseplate is as level as possible. Tightening carriage bolts requires special care to prevent the baseplate warping when it is secured to vehicle floor. If baseplate warps, the vertical arms will not be parallel. Corrections can be made by shimming at appropriate locations. To help prevent warping, tighten the eight carriage bolts to 38 Nm in the following sequence:

2, 3, 6, 7, 1, 4, 5, 8

NOTE: Vertical arms must be parallel for proper operation. Adjust bolts as required. Best results are obtained when lift is mounted on a plywood, or similar material, sub-base. Shims, although best avoided, may be used if required.

4 ELECTRICAL INSTALLATION

CAUTION!



- Do not route a wire while it is connected to the battery.
- Route wires clear of moving parts, brake lines, and the exhaust system. Secure to the vehicle.
- When routing an electrical wire through vehicle floor or walls, use a grommet to protect wires from chafing.
- Check underside of vehicle before drilling to avoid damage to fuel lines, ventlines, brake lines, or wiring.

Refer to Diagram no. 4 for an overall schematic of the electrical installation.

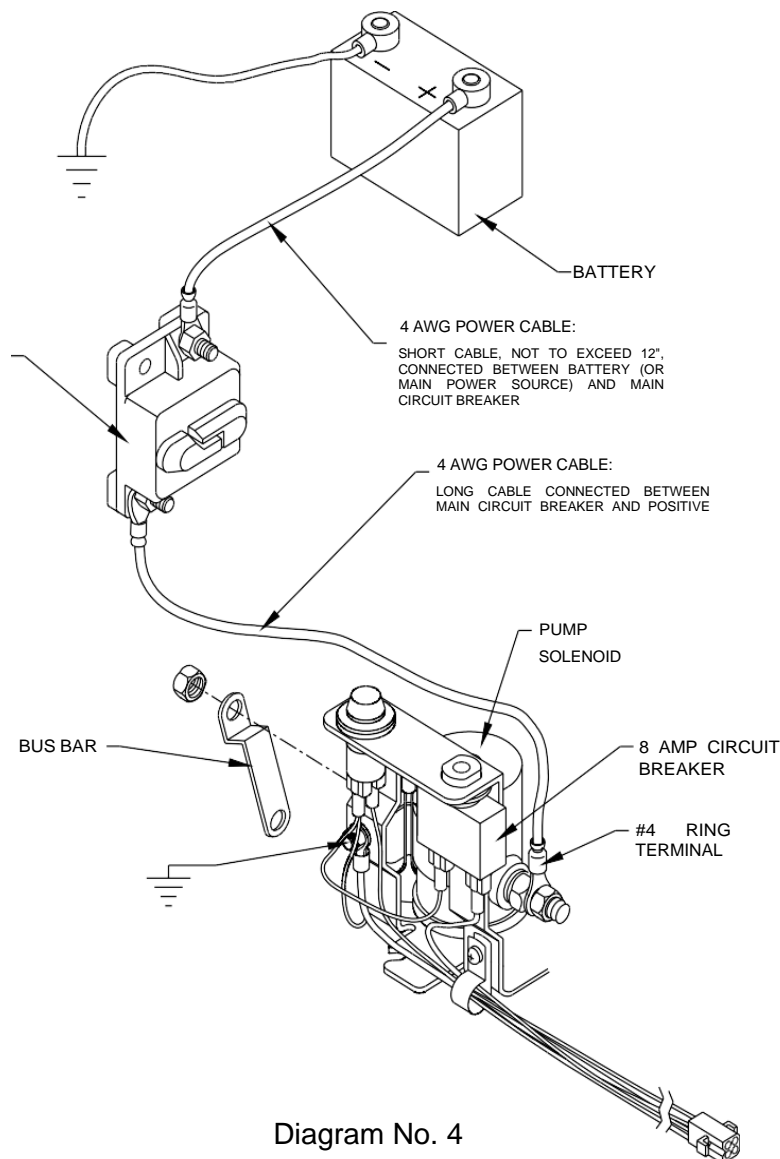

A. INSTALL MAIN CIRCUIT BREAKER

1. Disconnect battery.
2. Mount main circuit breaker inside engine compartment near battery. Mount within 300mm to minimize amount of unprotected cable. Avoid installing near a heat source.

B. ROUTE AND CONNECT MAIN POWER CABLE



CAUTION!

Check underside of vehicle before drilling to avoid damage to fuel lines, vent lines, brake lines, or wiring.

NOTE: For applications where power cable is to pass through sheet metal, drill a 20mm hole and use a wire clamp. For applications where cable is to pass through plywood, drill a 25mm hole and use black plastic grommet provided.

1. Refer to Diagram no. 5. Drill a hole through vehicle floor near or under pump solenoids so power cable can reach positive stud of side solenoid (the stud on side solenoid that is not connected to top solenoid with a bus bar). The hole should be drilled where it is covered by the pump cover.

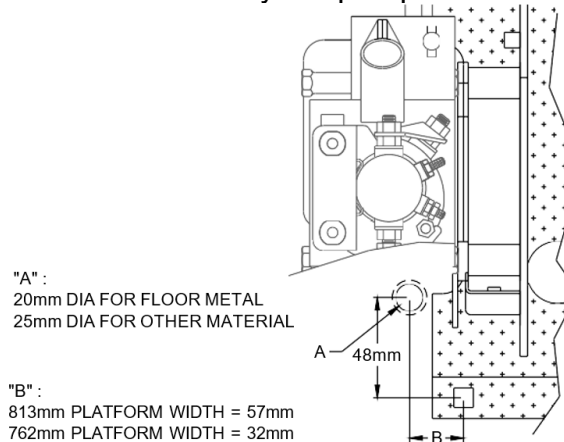

Diagram No. 5

NOTE: An 8 amp circuit breaker is provided for lift as a circuit protection device. Whatever circuit interface is supplied by the OEM, it should be capable of carrying 8 amps of continuous current.

2. Install ring terminals to each end of short power cable (300mm long), and one ring terminal to one end, and one end only, of long power cable using an appropriate crimp tool (such as Ricon P/N 26553).
3. Connect end of long 4 AWG power cable (with ring terminal) to main circuit breaker, then route power cable underneath vehicle floor and up through hole in floor.
4. Verify that power cable is secure. Bind power cable to pump assembly harness and to pump motor using cable ties. Avoid pinch points, exhaust system, any moving parts, and brake lines



CAUTION!

Be sure that there is no interference with any parts that could damage power cable or other wires in any way.

5. Refer to Diagram no. 6. Cut any excess wire from long cable, install remaining heavy ring terminal to unterminated end of long cable, and connect it to live side of solenoid. Verify that red wire from main circuit breaker (if applicable) is connected to positive solenoid pole.



CAUTION!

Be sure that harness does not interfere with any moving parts, or binds against any parts, or is pinched in any way.

6. Refer to Diagram no. 7. Connect RICON hand-held control pendant to lift and secure control cable to lift with cable clamp.
7. Install wall portion of pendant dovetail clip in an appropriate safe location.

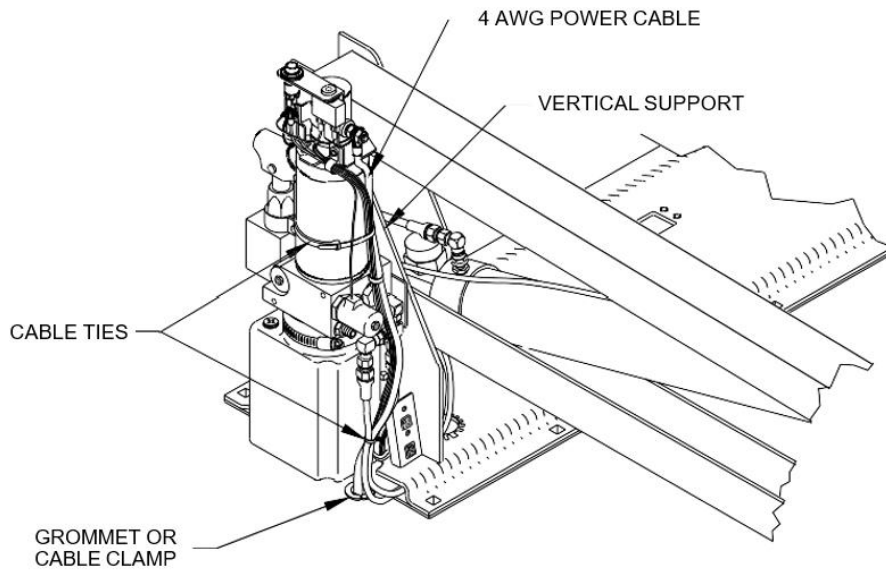

Diagram No. 6

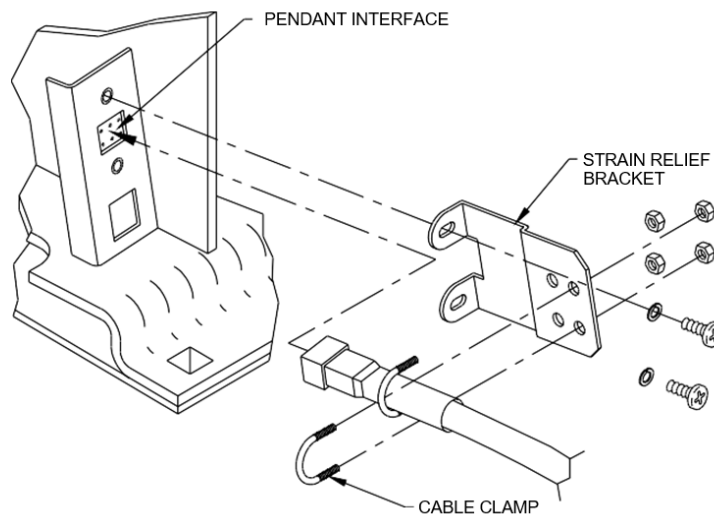

Diagram No. 7

C. GROUND CONNECTIONS

12VDC powered lifts are chassis grounded and do not require a separate ground cable connection to battery.

However, if lift electrical system is connected to chassis with a cable, the cable must be attached in a manner that provides a reliable electrical connection. If ground cable is attached to an existing ground circuit, the circuit must be capable of conducting an additional 90 amps to the negative battery terminal.

D. INTERLOCK INSTALLATION

An interlock device can be installed to prevent unsafe operation of the lift. This interlock device consists of a switch mounted near the driver seat that interrupts power to the lift control circuitry.

The installer must verify that none of the original equipment circuit breakers, fuses, or solenoids are bypassed, removed, or altered. Be sure that no wires are left frayed or hanging loose after installation of interlock device. If you have any questions about the proper installation of this interlock device, please contact our Product Support Department.



WARNING!

Do not operate lift unless you are certain that the integrity of lift electrical circuits has been maintained.



CAUTION!

Wiring attached directly to the positive battery terminal is not protected against short circuits and therefore must be a length of 300mm or less. This wiring must be routed in a manner that prevents pinching or abrasion by vehicle parts. If the power source for the interlock circuit comes from an existing fuse panel, the circuit must be capable of supplying an additional 8 amps of current



CAUTION!

All connectors utilized on interlock circuit must be a fully insulated type.

Refer to Diagram 8. This method interrupts power between the lift 8-amp circuit breaker and vehicle battery. The installer must provide an additional 8-amp circuit protector (or fuse).

1. Disconnect battery.
2. Connect a wire from battery to the additional 8 amp circuit protector that is 16 AWG or larger, and does not exceed 300mm in length.
3. Connect output side of additional 8 amp circuit protector to input side of interlock switch using 16 AWG or larger wire.
4. Disconnect wire connected to input side of the 8-amp breaker (located on pump assembly). Cover its exposed end with electrical tape or heat shrink tubing.
5. Connect output side of interlock switch to input side of 8 amp circuit breaker (on pump assembly) using 16 AWG or larger wire.
6. Dress and secure wires to prevent rubbing or chafing of insulation, and to relieve strain at wire connection points.
7. Re-connect battery.

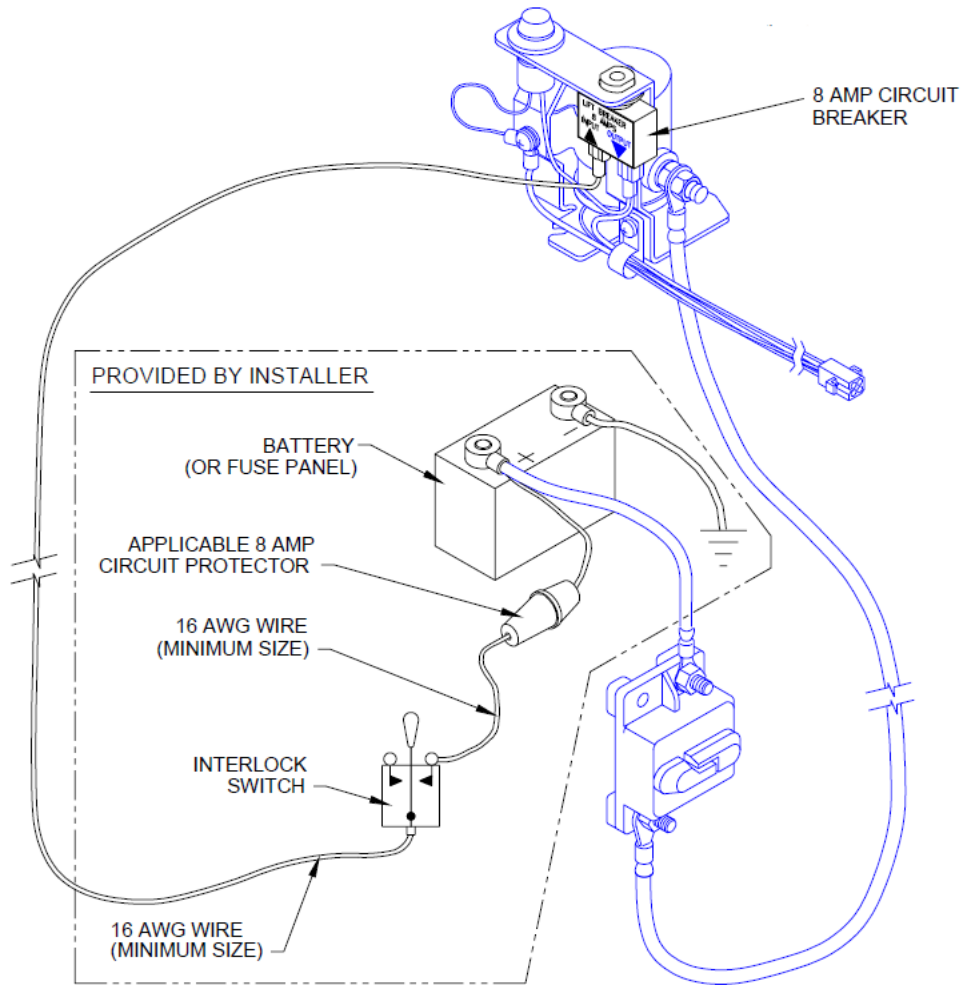
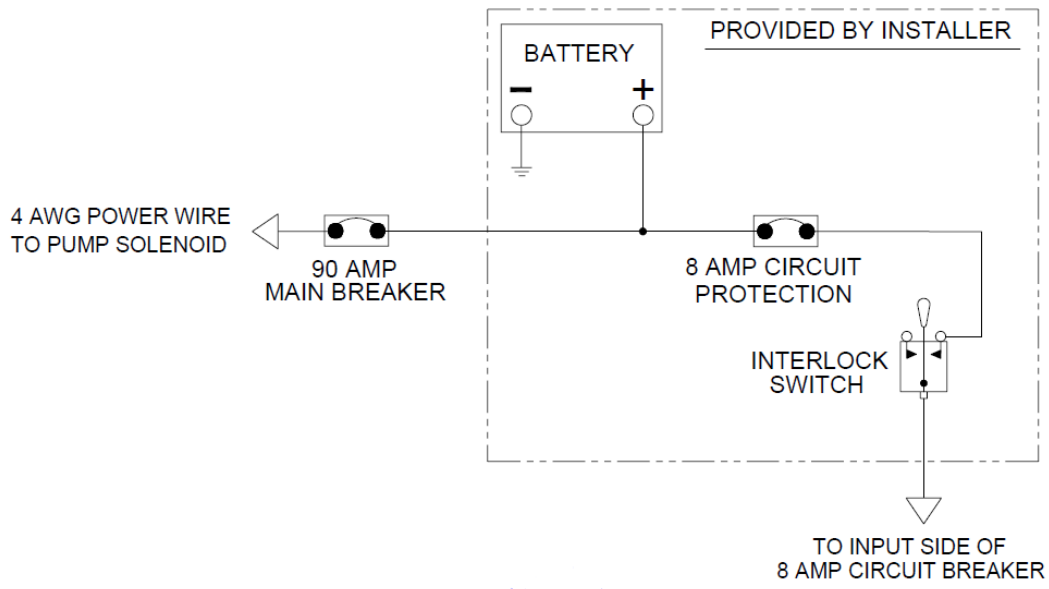

Diagram No. 8

E. LIMIT SWITCH ADJUSTMENT

For lift limit switch adjustment, refer to Diagram no. 9, and the following procedure.

NOTE: To avoid operational “dead-spots”, always adjust **DEPLOY CUTOFF SWITCH** before **RAISE CUTOFF SWITCH**.

NOTE: When loosening adjustment screws, apply enough pressure to screw to move block instead of screw. (The block might stick if insufficient pressure is applied to screw.)

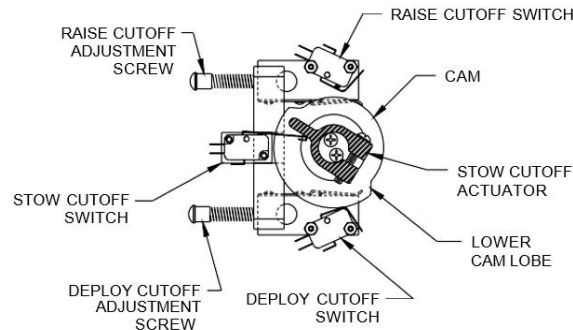

Diagram No. 9

- a. Fully DEPLOY platform
- b. Adjust RAISE CUTOFF ADJUSTMENT SCREW and DEPLOY CUTOFF ADJUSTMENT SCREW 6-8 turns **counter-clockwise** and then push screws FORWARD
- c. Cycle platform to STOW then DEPLOY.
- d. When in DEPLOY position, platform should stop at an angle and NOT even with vehicle floor. If not, turn DEPLOY CUTOFF ADJUSTMENT SCREW an additional 2- 3 turns **counter-clockwise**, push screw forward, STOW then DEPLOY platform, then repeat this step.
- e. Cycle platform to RAISE position.
- f. When in RAISE position, platform should stop short of vehicle floor level. If not, turn
- g. RAISE CUTOFF ADJUSTMENT SCREW an additional 2-3 turns **counter- clockwise**, push screw forward, cycle platform DOWN then UP, then repeat this step.
- h. Cycle platform to STOW then DEPLOY
- i. Push and hold control pendant DEPLOY button. Slowly turn DEPLOY CUTOFF ADJUSTMENT SCREW **clockwise** until platform “jogs” down to vehicle floor level, then stop turning screw and release DEPLOY button.

NOTE: Refer to Diagram no. 10. Make sure that clearance between knuckle actuator saddle and parallel arm is 3mm minimum (distance may be 12mm maximum and unequal for left and right arms).

- j. Position platform at ground level then RAISE until it stops.
- k. Push and hold control pendant RAISE button. Slowly turn RAISE CUTOFF ADJUSTMENT SCREW **clockwise** until platform “jogs” up to vehicle floor level, then stop turning screw and release RAISE button.

NOTE: If lift does not operate after 1-2 full turns of adjustment screw, cycle platform UP and DOWN (the RAISE CUTOFF SWITCH is less sensitive than DEPLOY CUTOFF SWITCH.)

- l. Cycle platform through all functions (DEPLOY, LOWER, RAISE, and STOW) to verify correct adjustment. Refer to Diagram 11 if necessary.

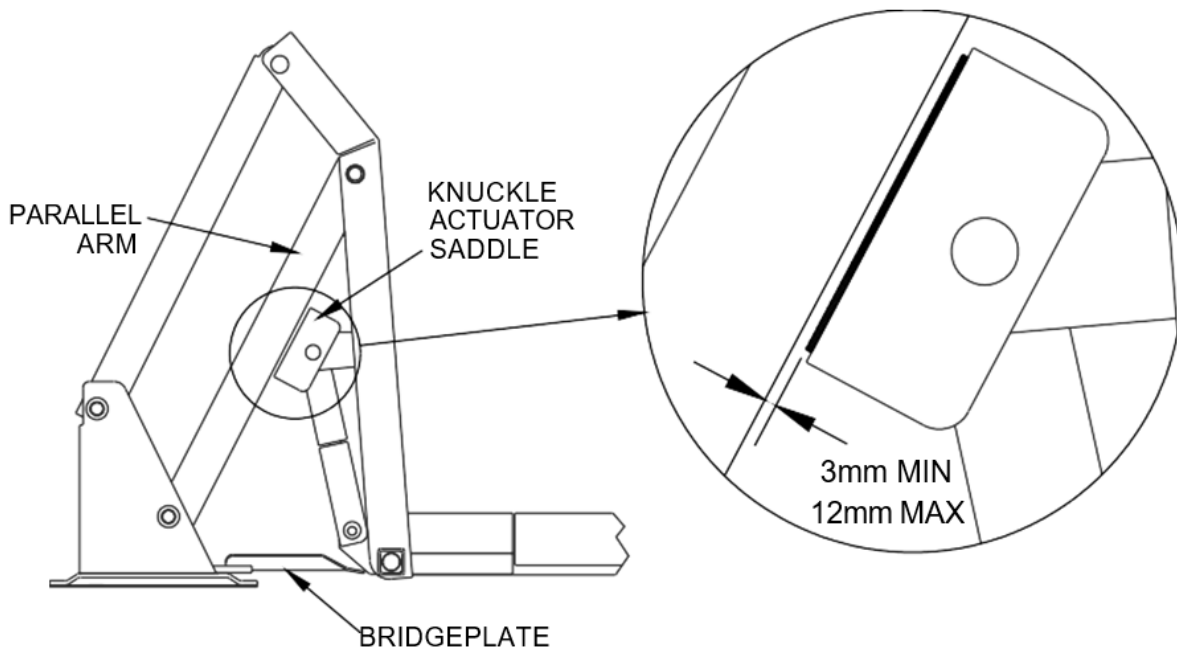

Diagram No. 10

TABLE 2-1: LIMIT SWITCH ADJUSTMENT CHART			
COMPONENT	SYMPTOM	CORRECTIVE ACTION	ADJUSTMENT PROCEDURE
Fold cutoff actuator	Lift does not fold tightly.	Rotate collar counter-clockwise.	With lift fully folded (handrails should be folded tight against vertical arms), rotate actuator so that fold cutoff leg barely trips fold cutoff switch.
	Pump runs continuously.	Rotate collar clockwise.	Test lift. Pump should cutoff when lift is folded tight.
Up cutoff adjustment screw	Lift stops low.	Adjust screw clockwise.	Adjust up cutoff switch so that lift stops just before first knuckle actuator saddle or roller touches underside of lower parallel arm. (Saddle or roller should be about 3mm from lower parallel arm.)
	Lift stops high.	Adjust screw counter-clockwise.	
Out cutoff adjustment screw	Lift stops low.	Adjust screw counter-clockwise.	Adjust lower limit switch so that lift stops just below "Up" cutoff described in above step. This will give the necessary overlap to avoid "dead" spots.
	Lift stops high.	Adjust screw clockwise.	
END OF TABLE			

Diagram No. 11

5 VERIFY INSTALLATION

- Be certain that no vehicle components interfere with operation of CityFix.
- The CityFix is designed to handle 500kgs. The vehicle structure must be capable of supporting all loads produced during lift operation, as well as those forces caused by motion of vehicle when it is driven.



CAUTION

- Do not operate lift when test weight is on platform. This load test is designed to test the lift mounting method, not the lift capacity. Remove test weight immediately after test.
 - Vehicle suspension will compress and vehicle will lean when test weight is placed on platform. If weighted platform contacts ground, remove weight, raise platform, and retest.
-
- The lift must be test loaded to 125% of its rated 500kgs load capacity to verify integrity installation. Position lift platform 50mm – 150mm above the ground, place 625kgs in center of platform, and inspect lift mounting points. REMOVE TEST WEIGHT.
 - Run lift through several complete cycles while checking for proper operation.

