

INTERLIFT

BY **PALFINGER**

INSTALLATION MANUAL & CHECK OFF SHEET

ILP 25, 2500 lbs. Capacity

ILP 33, 3300 lbs. Capacity

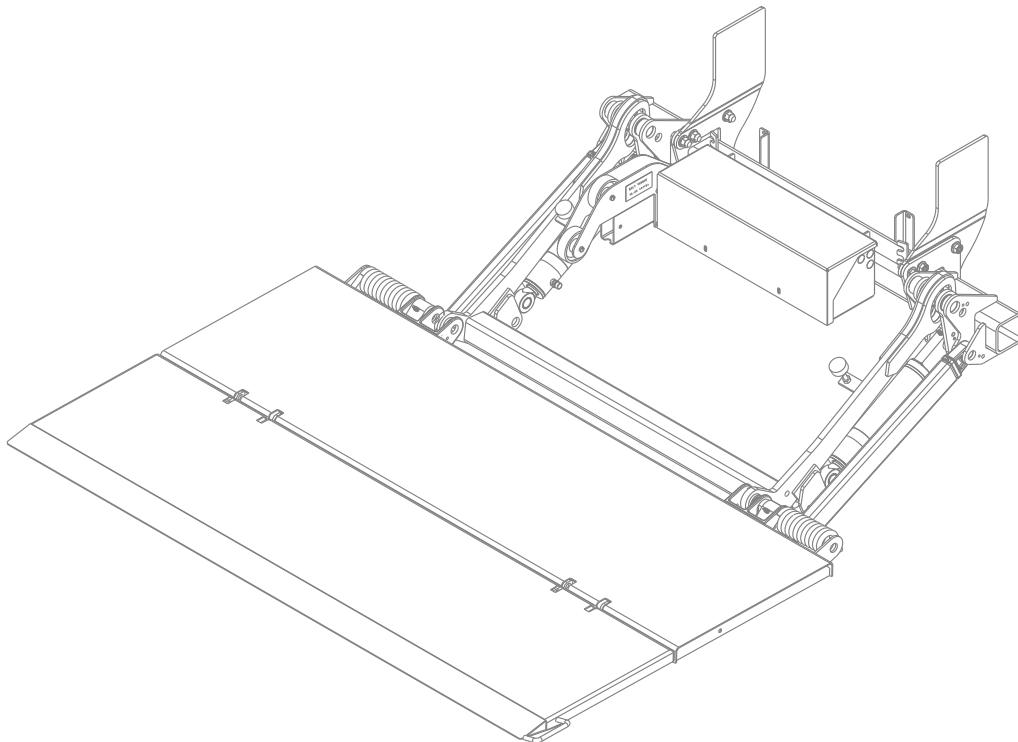

ILP 25/33 Installation Manual

Document Part Number: 90-0116-000 / 16-684_90-00_00-00

ECN-M1723, Rev. 1.5, 12-07-23

Copyright © 2023 Palfinger Interlift, LLC.

All rights reserved.

**Information in this document is subject to change without notice.
Visit www.palfinger.com for up to date information and notifications.**

**If you received this product with damaged or missing parts,
contact INTERLIFT Liftgates at (888)-774-5844**

Parts Order/Inquiries

liftgateparts@palfinger.com

Technical Support

technicalapplications@palfinger.com



**15939 Piuma Ave.
Cerritos, CA 90703
Tel (888) 774-5844
Fax (562) 924-8318**



**572 Whitehead Road.
Trenton, NJ 08619
Tel (609) 587-4200
Fax (609) 587-4201**

Table of Contents

1 Manual Updates 5

2 Safety Information 6

3 Important Information 7

4 Tools For Installation 9

 4.1 Boxed Items..... 9

5 General View of Liftgate(s)..... 10

 5.1 ILP General Overview 10

 5.2 Important Dimensions 11

6 Installation Dimensions 12

7 Platform Compatibility 14

8 Chassis and Body Preparation - 800mm [31.50"] Liftarm..... 15

9 Chassis and Body Preparation - 900mm [35.40"] Liftarm..... 16

10 Gate Installation..... 17

 10.1 Sill Cutouts..... 17

11 Bed Extension Installation 18

 11.1 Bed Extension (Weld-On) 18

 11.2 Bed Extension (Bolt-On) 22

12 Liftgate Installation (Truck)..... 24

 12.1 Liftgate Installation 24

 12.2 Adjusting the Platform 32

 12.3 Final Steps of Installation 36

 12.4 Sub-frame Installation (Optional)..... 37

 12.5 Dock Bumper Installation - Weld-On (Optional)..... 38

 12.6 Dock Bumper Installation - Bolt On (Optional)..... 39

 12.7 Walkramp Cradle Installation (Optional)..... 41

13 Electrical Installation..... 46

 13.1 Electrical Wiring – Batteries – Truck/Trailer..... 47

 13.2 Cable Routing 48

 13.3 Connecting Power to Liftgate 48

 13.4 Wire Crimping 49

 13.5 Circuit Breaker Installation 49

 13.6 Toggle Switch Installation 50

 13.7 Liftgate Shut-Off Switch 52

 13.8 2-Button Hand Held Remote Control (Optional) 54

 13.9 Electrical Schematic (Gravity Down) 56

13.10 Electrical Schematic (Power Down) 57

14 Hydraulic Schematic (Gravity Down) 58

14.1 Hydraulic Schematic (Power Down) 59

14.2 Hydraulic Fluid 60

15 Decal Placement and Inspection 61

16 Lubrication 63

17 Final Inspection Check List 64

Company Information:

Company Name: _____

Advisor Name: _____

Vehicle Year Make & Model: _____

Liftgate Information:

Liftgate Serial Number: _____

Liftgate Model Number: _____

Date of Purchase: _____

Date of Installation: _____

1 Manual Updates

Revision	Description
v1.1	<ul style="list-style-type: none"> • Changed product name from PLP to ILP. • Updated F-Dimensions on Section 8.
v1.2	<ul style="list-style-type: none"> • Added walkramp Section 12.7. • Revised Sections 13.9, 13-10: Toggle switch wire colors updated.
v1.3	<ul style="list-style-type: none"> • Section 6: Dimension Sheets • Updated Section 11.2: Updated bolt-on hole pattern. • Section 12 (all): Updated steps and detailed instructions. • Section 12.3: Bolt removal from swing fixture • Section 13.9-13.10: Power and Gravity Down wiring schematics
v1.4	<ul style="list-style-type: none"> • Updated pictorials throughout manual to match actual product.
v1.5	<ul style="list-style-type: none"> • Changed the logos, from Palfinger to Interlift

2 Safety Information

This manual follows the Guidelines set forth in “ANSI Z535.4-2007” for alerting you to possible hazards and their potential severity.

DANGER

! **DANGER** indicates an imminently hazardous situation which, if not avoided, **will result** in death or serious injury.

WARNING

! **WARNING** indicates potentially hazardous situation which, if not avoided, **could result** in death or serious injury.

CAUTION

! **CAUTION** indicates a potentially hazardous situation which, if not avoided, **may result** in minor or moderate injury.

CAUTION

CAUTION without the safety alert symbol is used to address practices not related to personal injury.

(In this manual it is used to alert the user to potentially hazardous situation which, if not avoided, may result in property damage.)

NOTICE

NOTICE without the safety alert symbol is used to address practices not related to personal injury. *(In this manual it is to alert you to special instructions, steps, or procedures.)*

- Always be aware of your surroundings.
- Wear eye protection at all times during installation.
- Ear protection and gloves should be used when necessary.

WARNING

Improper operation of this liftgate may result in severe personal injury or death. **DO NOT** operate unless you have been properly instructed, have read and are familiar with the procedures in this manual. This manual has been designed to illustrate the steps needed for the basic installation of the ILP liftgate. It also provides safety information and simple preventive maintenance tips.

3 Important Information

Before Getting Started

“READ FIRST”

NOTICE

The ILP liftgate is a heavy duty industrial hydraulic lifting device. Performance and reliability are closely related to proper installation, battery cable connections, and grounding. All grounding surfaces **MUST** be cleaned, prepped, and sealed per this manual. “Cut to size” cables **MUST** be properly crimped and sealed as factory supplied. All connections **MUST** be dressed with dielectric grease or equivalent sealer.

- Review liftgate invoice, packing slip, and installation drawing to assure delivery of correct gate and complete delivery of accessories and optional equipment.
- Refer to Section 8 and verify that the truck/trailer has sufficient bed height and mount clearance for the selected gate. Keep in mind that the truck/trailer can settle several inches depending on suspension, over hang, addition of equipment and loading.
 1. If the minimum bed height is not maintained the gate will not fold or unfold
 2. If the maximum bed height is exceeded the gate may not reach the ground
- Read and understand the “Installation Manual” and “Owner’s Manual” in their entirety before starting the installation.
- Refer to your truck manufacturer’s instructions before adding any auxiliary equipment. Installer is responsible for compliance with this manual, OEM and FMVSS requirements.
- All welding should be performed by qualified personnel per AWS standards.
- Always Ground closest to your welding point to prevent arcing through moving parts or electrical parts.
- Contact INTERLIFT Liftgates for Special Installations not covered in this Installation Manual.
- Do not paint cylinder shafts or nylon bearings (Use non-chlorinated brake cleaner to remove over spray)
- Final Check-Off-Sheet at rear of this manual **MUST** be filled out and sent to INTERLIFT Liftgates for warranty activation.
- Refer to Owner’s Manual for Operation and maintenance information.
- Check the battery voltage before installation. Flooded lead acid batteries should measure 12.6V and AGM batteries should measure 12.8V. If batteries are not at these voltages, fully charge before installation.

NOTICE

This manual is not intended for use as a repair or troubleshooting guide. Repairs should be performed by a INTERLIFT Liftgates Authorized Service Center.

This Manual has been designed for use in conjunction with the ILP series liftgate only which is designed for different capacities and features.

- 1) Refer to the serial number tag on the liftgate, it can be found on the driver side liftarm, as shown in **Fig.1**.

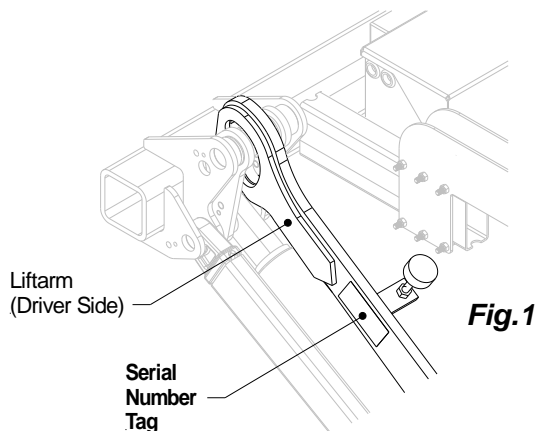

- 2) Ask your employer or lessor;
- 3) Call your INTERLIFT Liftgates Authorized Service Center for assistance.
- 4) Call INTERLIFT Liftgates for assistance in the USA at 888-774-5844. You can also contact INTERLIFT Liftgates by fax (562) 924-8318 or on the internet at www.palfinger.com

For technical support, contact INTERLIFT Liftgates or an authorized INTERLIFT service center. www.palfinger.com

4 Tools For Installation

Metric Wrench Set	Basic Screwdrivers	Assorted Pliers	Wire Crimp Pliers
Digital Multi-Meter	Snap Ring Pliers	Hammer	SAE & Metric Allen key Set
½" Impact & Sockets	SAE & Metric Socket Set	Assorted Drill Bits	Floor Jack or Equiv.
Small to medium bottle Jack	Forklift or Over Head Crane	Hand Held Grinder	Paint Gun & Accessories
Pry Bar	3/8 Drill Motor	Grease Gun	Heat Gun or Equiv.
Min. 250 Amp Welder	Cutting Torch or Equiv.	Safety Goggles	Framing Square

4.1 Boxed Items

Installation for each boxed item can be found throughout this installation manual.

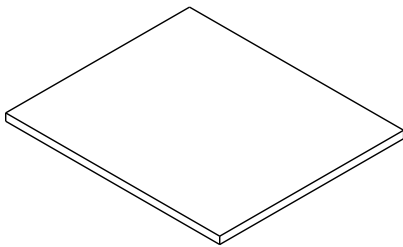

Owner's Manual
1 pc

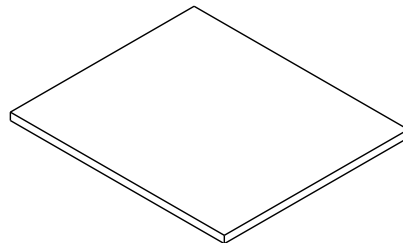

Installation Manual
1 pc

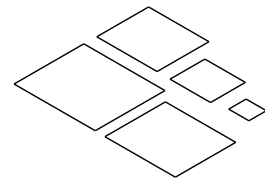

Decal Kit
13 pcs

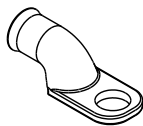

Battery Lug, 5/16"
1 pc

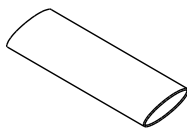

Heat Shrink, ø1/2" x 3"L
1 pc

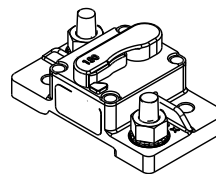

Circuit Breaker
1 pc

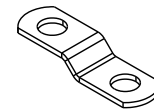

Copper Bus Bar
1 pc

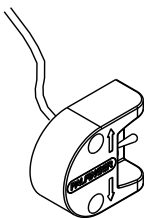

Toggle Switch
1 pc

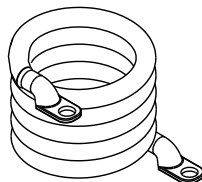

Power Cable
1 pc

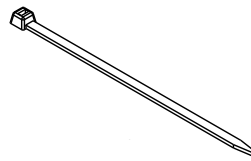

8" Nylon Cable Tie
15 pcs

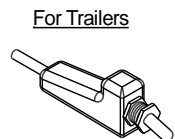
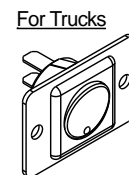

Shut Off Switch
1 pc

5 General View of Liftgate(s)

5.1 ILP General Overview

Available Options:

- Lift Capacities: 2500 lbs. or 3300 lbs.
- Power Down (Electrical) – Power (motor) assisted operation for lowering platform.
- Power Down (Mechanical) – Spring assisted operation for lowering platform.
- Standard Configuration - No bumper **Fig.2**.
- Center Bumper- Three piece bumper assembly positioned in the center of the mount frame. **Fig.3**.
- DOT Bumper- Three section bumper that meets Department of Transportation requirements. **Fig.4**.
- Hitch Bumper – Three piece assembly with hitch receiver and “D” rings **Fig.5**.

**No spring installed on left side for 42” and 48” aluminum platforms only*

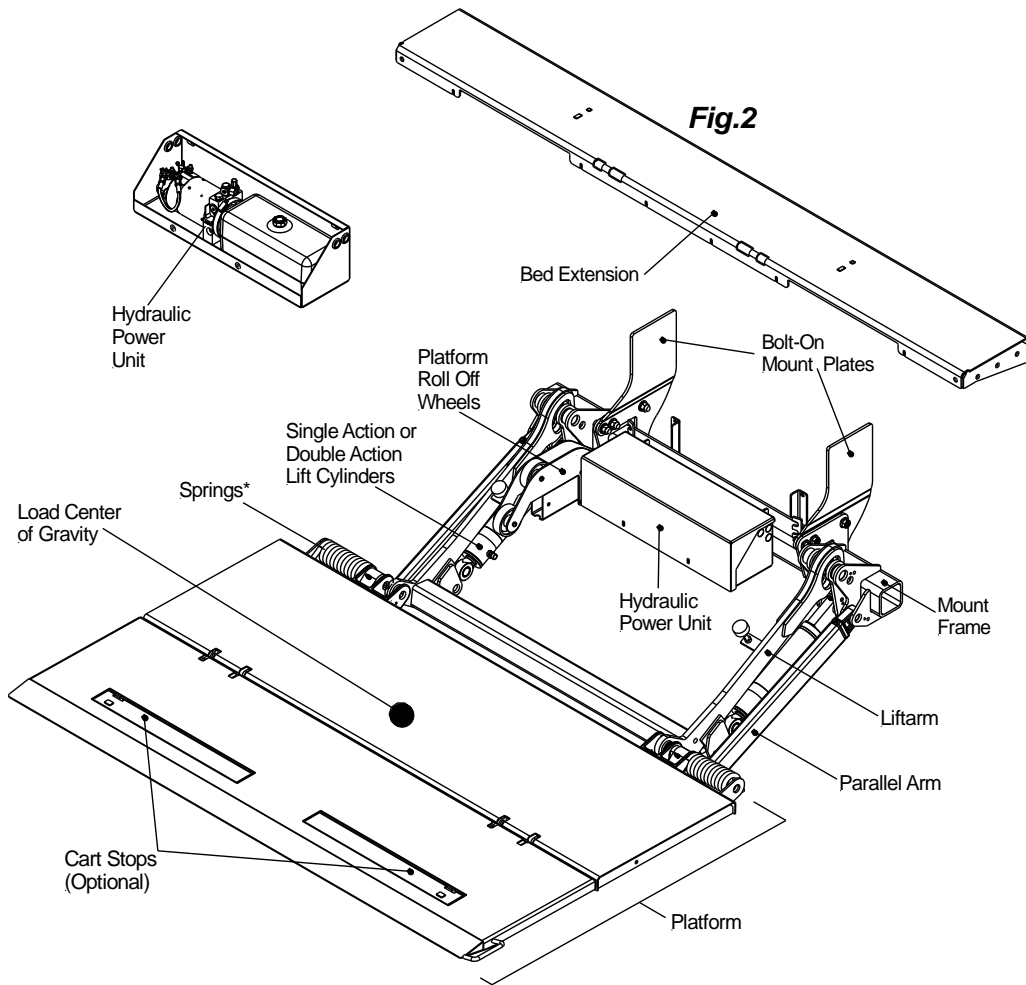

ILP Liftgate Bumper Optional Configurations

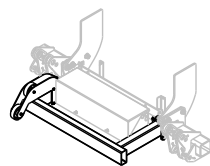

Center Bumper
Fig.3

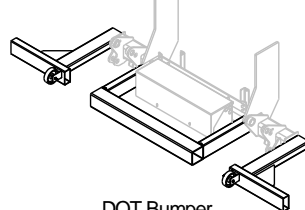

DOT Bumper
Fig.4

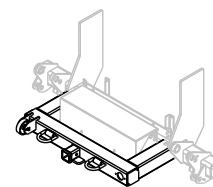

Hitch Bumper
Fig.5

NOTICE

5.2 Important Dimensions

Minimum Bed Height dimensions are ALWAYS MAXIMUM LOADED TRUCK.

Maximum Bed Height dimensions are ALWAYS DRY UNLOADED TRUCK.

- Installing a gate at or close to minimum bed height normally results in a gate that will NOT open and close from stored position if the minimum floor height is exceeded when truck is loaded.
- Ensure trailer/truck body does not interfere with installation or operation of the ILP liftgate series.
- It is not recommended to cut, torch, or remove support materials from trailer/truck. Removing gussets, stiffeners, light rings, or other such support structures may VOID your trailer/truck warranty.
- Call technical support before starting the installation if any questions or concerns arise on mounting dimensions or procedures.
- Minimum clearance required for an ILP liftgate to install on a vehicle is 27" of clearance for 800mm liftarms, and 31" of clearance for a 900mm liftarm. Clearance area should be free of any obstruction that will prevent the installation of the liftgate, **Fig.6**.

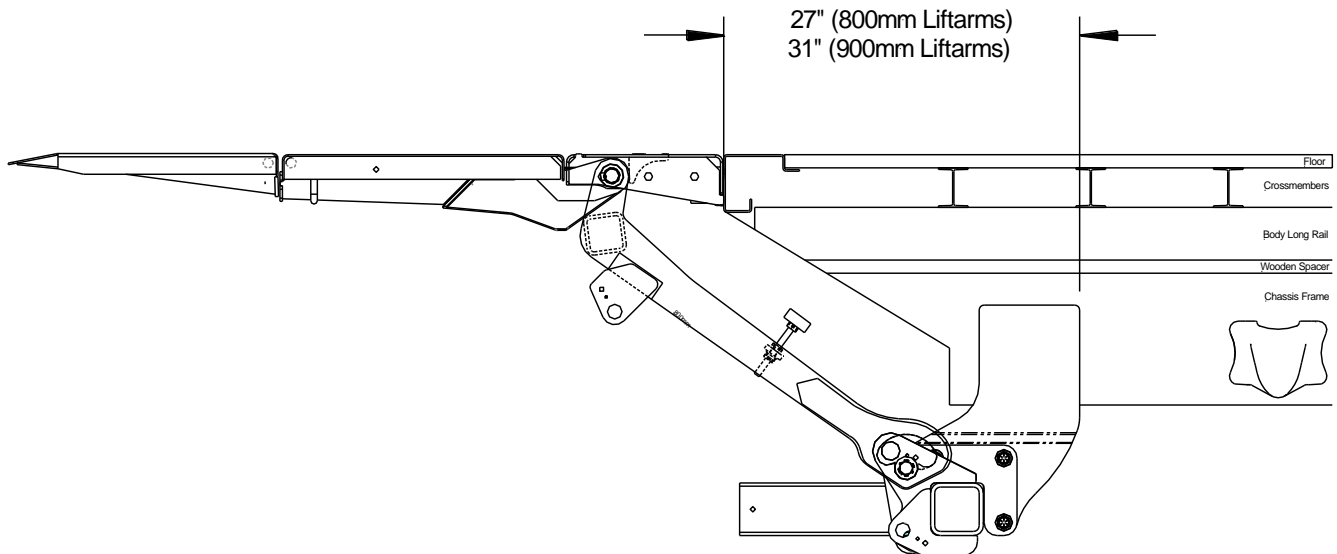

Fig.6

6 Installation Dimensions



Trailer Chassis Dimension Sheet

Customer Information

Quote#/SO#: _____
 Company: _____
 Phone: _____
 Email: _____ @ _____

Liftgates Information:
Model:
Capacity:
Platform Size:
Platform Material:

Trailer Information

Trailer Specifications:	Type of Body (check applicable) <input checked="" type="checkbox"/>	Type of Rear Door (check applicable) <input checked="" type="checkbox"/>
Manufacturer: (ex. Utility)	Van	Flip-Up
GVWR: (ex. 68,000 lbs)	Flatbed	Roll-Up
Length: (ex. 53ft)	Reefer	Swing
Width: (96", 102")	Other (specify) _____	Other (specify) _____

Trailer Dimensions

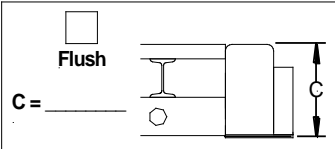
- A = Bedheight: Top of trailer floor to level ground (with airbags up):.....
 - B = Top of floor to bottom of trailer cross member:.....
 - C = Rear sill height (Top of floor to bottom of buck plate): *If Stepped sill complete M,N; If Tapered sill complete O, P.*
- 

Flush
C = _____

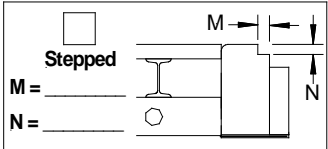

Stepped
M = _____
N = _____

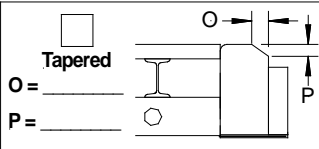

Tapered
O = _____
P = _____
- D = Crossmember height:.....
 - E = Tire to end of vehicle body:.....
 - F = Bogie to end of vehicle body..... Sliding Suspension? Yes _____ No _____
If Yes complete G, H, I, K, and L dimensions
 - G = Inside horizontal width of sliding suspension angles:.....
 - H = Diameter of sliding suspension holes:.....
 - I = Hole spacing:.....
 - J = Bottom of crossmembers to bottom of sliding ramp box, if applicable:.....
 - K = Rear sill face to first slider hole:.....
 - L = Top of floor, where liftgate platform will meet floor, to the center of the trailer slider holes:.....
 - X = Eyebrow depth:.....
 - Z = Top of floor, where the liftgate platform will meet the top of the eyebrow:.....

Notes:

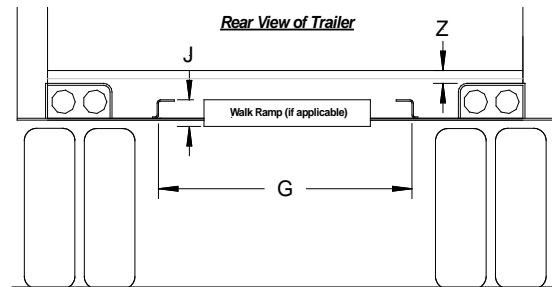
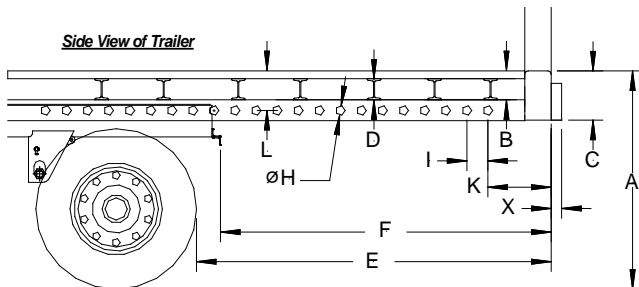

90-9813-002_b



Truck Chassis Dimension Sheet

Customer Information

Quote#/SO#: _____
 Company: _____
 Phone: _____
 Email: _____ @ _____

Liftgates Information:
Model
Capacity
Platform Size
Platform Material

Truck Information

Truck Specifications:	
Manufacturer: (ex. Hino)	
GVWR: (ex. 68,000 lbs)	
Length: (ex. 53ft)	
Width: (96", 102")	

Type of Body (check applicable) <input checked="" type="checkbox"/>	
Van	<input type="checkbox"/>
Flatbed	<input type="checkbox"/>
Reefer	<input type="checkbox"/>
Other (specify) _____	<input type="checkbox"/>

Type of Rear Door (check applicable) <input checked="" type="checkbox"/>	
Flip-Up	<input type="checkbox"/>
Roll-Up	<input type="checkbox"/>
Swing	<input type="checkbox"/>
Other (specify) _____	<input type="checkbox"/>

Truck Dimensions

- A = Bedheight:..... Loaded Bedheight:.....
- B = Top of floor to bottom of frame:.....
- C = Rear sill height:.....
- D = Spring hanger to end of body (if applicable):.....
- E = Air bag suspension to end of body (if applicable):.....
- F = Tire to end of vehicle body:.....
- G = Gas tank to end of body (if applicable):.....
- H = Fuel filler hole to end of body (if applicable):.....
- I = Bottom of frame to bottom of gas tank (if applicable):.....
- J = Top of floor to bottom of sliding walk ramp (if applicable):.....
- K = Frame Width: Width of chassis frame:.....
- L = Frame Height: Height of chassis frame:.....

Notes:

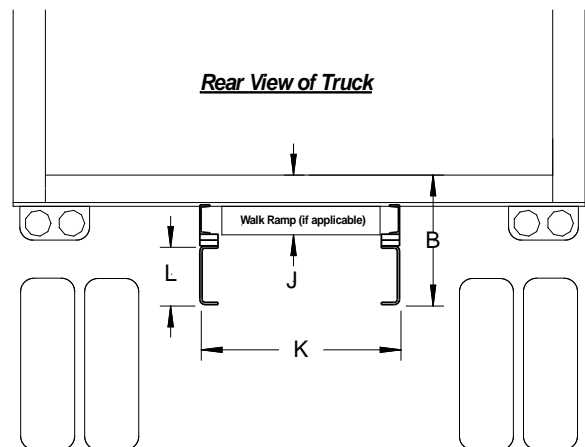
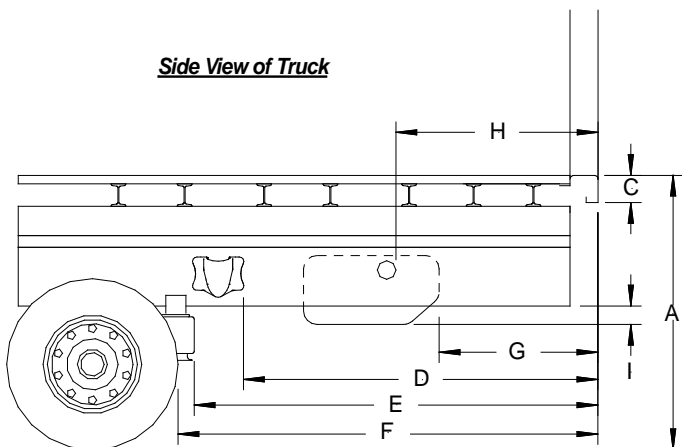

90-9813-003_b

7 Platform Compatibility

NOTICE

Vehicle bed heights are absolute minimum for the corresponding platform sizes when the vehicle is fully loaded and gassed.

800mm [31.50"] Liftarm		
Vehicle Bed Height	Platform Sizes	
	48"x80"	54"x80"
52	✓	✓
51	✓	✓
50	✓	✓
49	✓	✓
48	✓	✓
47	✓	✓
46	✓	✓
45	✓	✓
44	✓	✓
43	✓	✓
42	✓	n/a
41	✓	n/a
40	✓	n/a
39	✓	n/a
38	✓	n/a

n/a = not available

900mm [35.40"] Liftarm			
Vehicle Bed Height	Platform Sizes		
	48"x80"	54"x80"	60"x80"
56	✓	✓	✓
55	✓	✓	✓
54	✓	✓	✓
53	✓	✓	✓
52	✓	✓	✓
51	✓	✓	✓
50	✓	✓	✓
49	✓	✓	✓
48	✓	✓	✓
47	✓	✓	✓

8 Chassis and Body Preparation - 800mm [31.50"] Liftarm

NOTICE

- Decrease ground clearance only to clear obstructions (i.e. fuel tanks, cross members, hitches, etc.) **WITHOUT EXCEEDING MAXIMUM "F" dimension of 26"**.
- Minimum bed height is when truck/trailer is loaded to Maximum GVW (Gross Vehicle Weight).
- "F" dimension: Mount and Ground clearance always relate to each other on a set floor height. If the "F" dimension is increased for a shorter mount clearance, the ground clearance will decrease.

- 1) **Bed Height:** Bed Height Ranges: Max=Unloaded / Min=Loaded Truck Measure from **TOP** of body floor to ground. Vehicle must be on a flat leveled surface when measuring.
- 2) **"F" Dim (Mount Frame Height):** Measure from top of Mount Frame to top of body floor.
- 3) **"K" Dim Ref. (Mount Clearance):** Measure from rear of body to front edge of Mount Plates.
- 4) **"G" Dim (Ground Clearance):** Measure from bottom of Mount Frame to ground.
- 5) **"A" Dim (Vehicle Body Cutout):** Measure from the rear of the sill towards the front of the vehicle.
- 6) **"B" Dim (Vehicle Body Cutout):** Measure from top of the sill down to the ground.
- 7) **800mm [31.50"] Liftarm:** Measure from center to center of pivot pins.

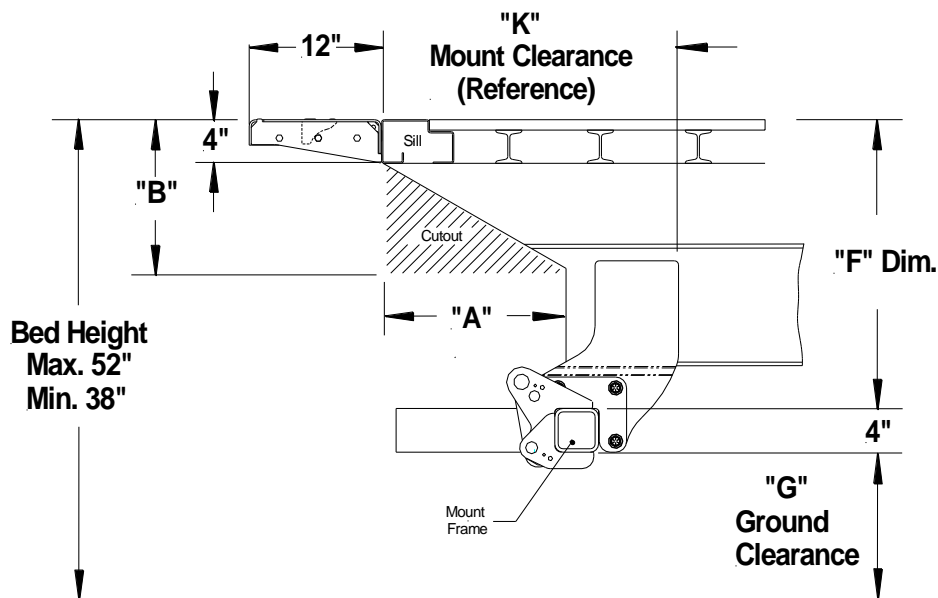

Mounting Dimension Table					
Mounting Dimensions for 800mm [31.50"] Liftarm			Chassis Frame Cutout Dimensions		
Bed Height (Landen)	F Dim.	G Dim.	K Dim.	A Dim.	B Dim.
52"-47"	26"	22"-17"	27"	19"	17"
47"-43"	23"	20"-16"	30"	20"	13"
43"-38"	20"	19"-14"	32"	18"	9"

G Dim = Bed Height – F Dim. – Mount Frame Height
 Never exceed any of the dimensions from the table when installing the liftgate.
 *Vehicle bed heights tend to lower 3"-4" when loaded.

9 Chassis and Body Preparation - 900mm [35.40"] Liftarm

NOTICE

- Decrease ground clearance only to clear obstructions (i.e. fuel tanks, cross members, hitches, etc.) **WITHOUT EXCEEDING MAXIMUM "F" dimension of 28"**.
- Minimum bed height is when truck/trailer is loaded to Maximum GVW (Gross Vehicle Weight).
- "F" dimension: Mount and Ground clearance always relate to each other on a set floor height. If the "F" dimension is increased for a shorter mount clearance, the ground clearance will decrease.

- 1) **Bed Height:** Bed Height Ranges: Max=Unloaded / Min=Loaded Truck Measure from **TOP** of body floor to ground. Vehicle must be on a flat leveled surface when measuring.
- 2) **"F" Dim (Mount Frame Height):** Measure from top of Mount Frame to top of body floor.
- 3) **"K" Dim Ref. (Mount Clearance):** Measure from rear of body to front edge of Mount Plates.
- 4) **"G" Dim (Ground Clearance):** Measure from bottom of Mount Frame to ground.
- 5) **"A" Dim (Vehicle Body Cutout):** Measure from the rear of the sill towards the front of the vehicle.
- 6) **"B" Dim (Vehicle Body Cutout):** Measure from top of the sill down to the ground.
- 7) **900mm [35.40"] Liftarm:** Measure from center to center of pivot pins.

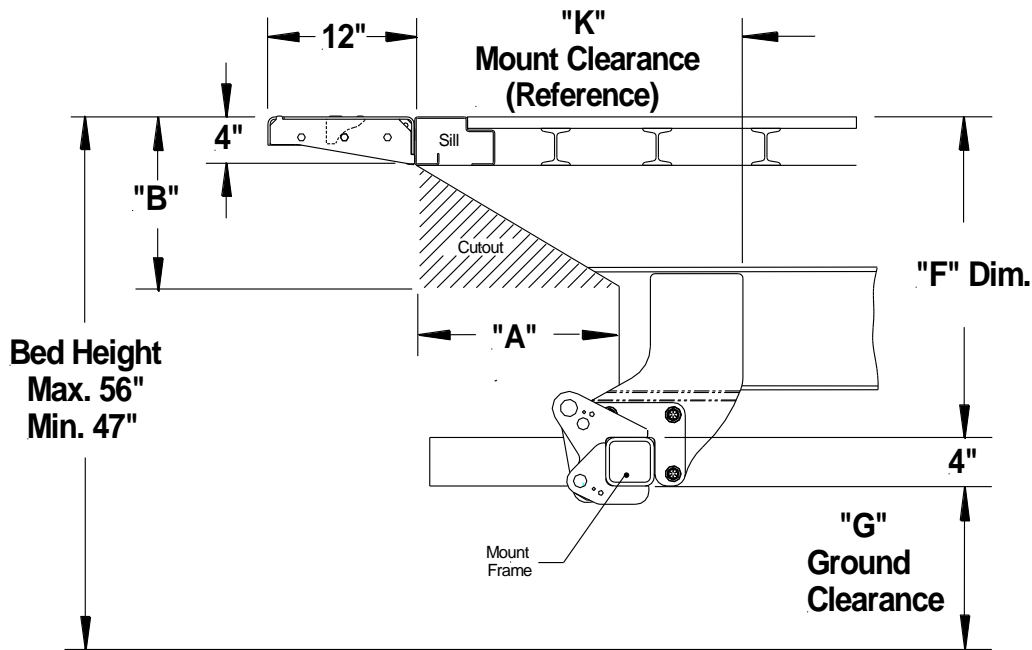

Mounting Dimension Table					
Mounting Dimensions for 900mm [35.40"] Liftarm				Chassis Frame Cutout Dimensions	
Bed Height (Landen)	F Dim.	G Dim.	K Dim.	A Dim.	B Dim.
56"-52"	28"	24"-20"	31"	21"	18"
52"-47"*	26"	22"-17"	32"	22"	15"

G Dim = Bed Height – F Dim. – Mount Frame Height
Never exceed any of the dimensions from the table when installing the liftgate.
***Vehicle bed heights tend to lower 3"-4" when loaded.**

10 Gate Installation

10.1 Sill Cutouts

To prevent interference with the platform the vehicles sill could require notching.

Options	
Sill Height	Action
4"	No sill notching required.
5"	If not notched, platform will be offset down approximately 1"-2" from bed extension.
Over 5"	Notch sill as show in Fig.7 . Notches will require reinforcement, Fig.8

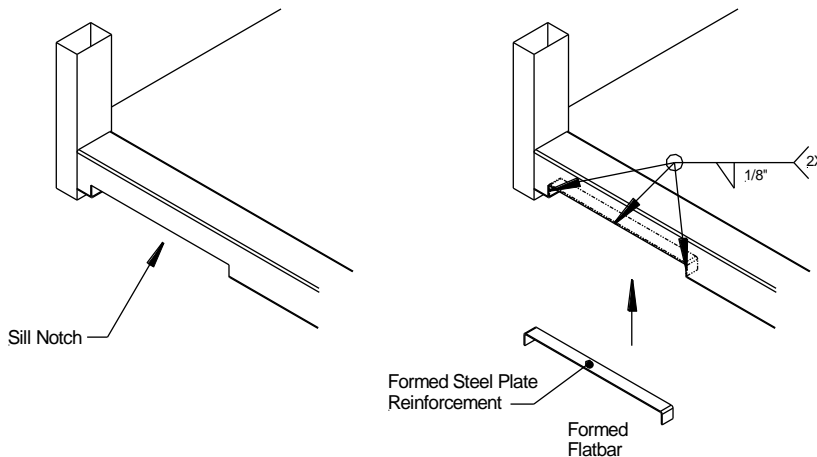
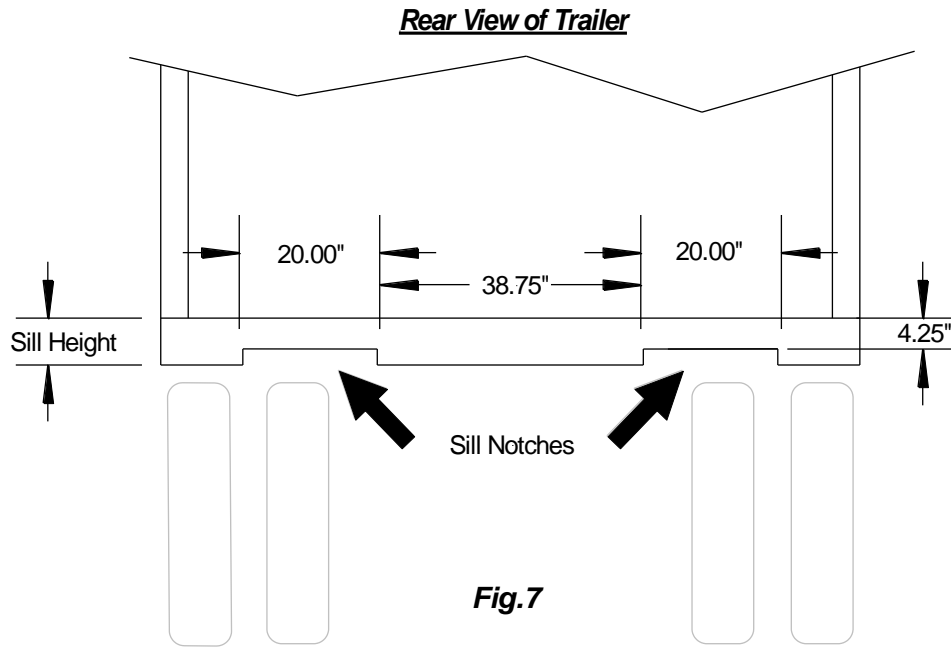

Reinforce all sill cutouts with flatbar, **Fig.8**

11 Bed Extension Installation

11.1 Bed Extension (Weld-On)

1. Mark the center of the vehicle body and the bed extension. Clamp the bed extension to the forklift forks, **Fig.9**. Maintain the bed extension centered and flush to the sill vertically and horizontally. Check for squareness before continuing.

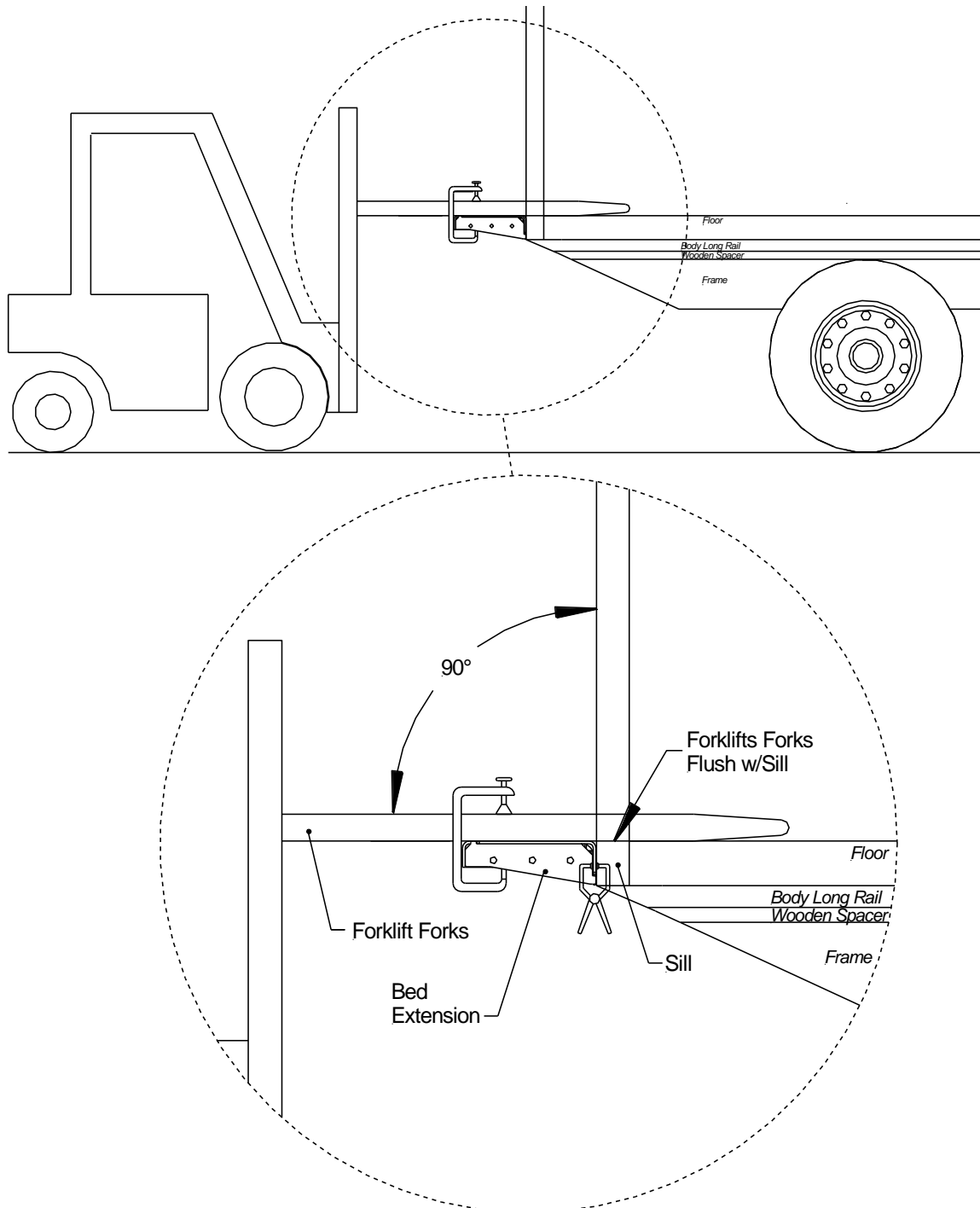

Fig.9

If using a hoist, make a hole on the edge of a 3" standard channel, **Fig.10**. Clamp the channels to the bed extension and attached the hoist to the 3" channels. Maintain the bed extension centered and flush to the sill vertically and horizontally. Check for squareness before continuing.

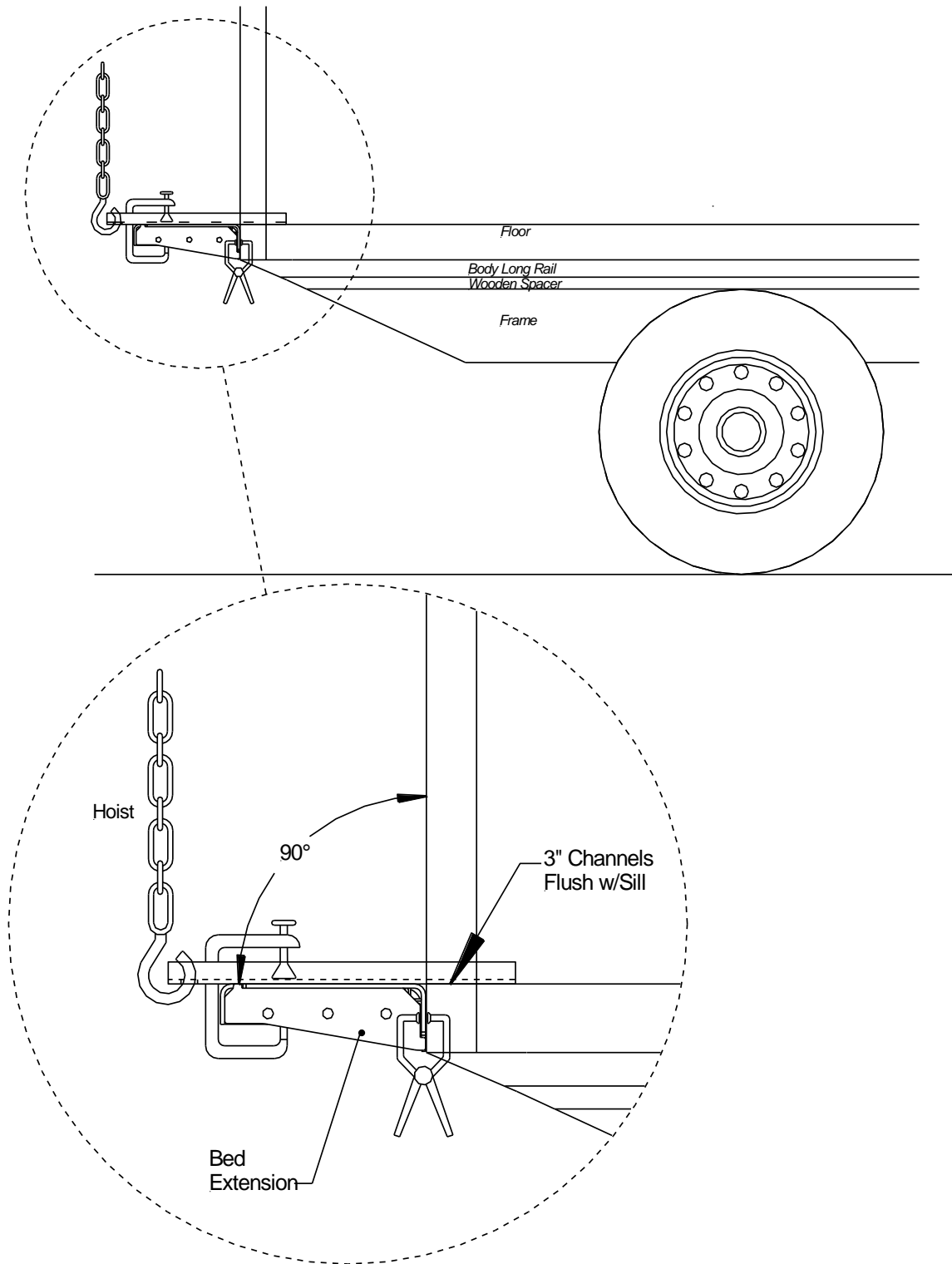

Fig.10

2. Weld $3/16"$ x $5"$ welds on each end on the bed extension. Keep $1"$ gap clearance on corner post seam line, **Fig.11**. All other welds shall be $3/16"$ x $2"$ centered on each rib, top and bottom of bed extension, **Fig.12**. Bed extension shall be flush with floor level, **Fig.13**.

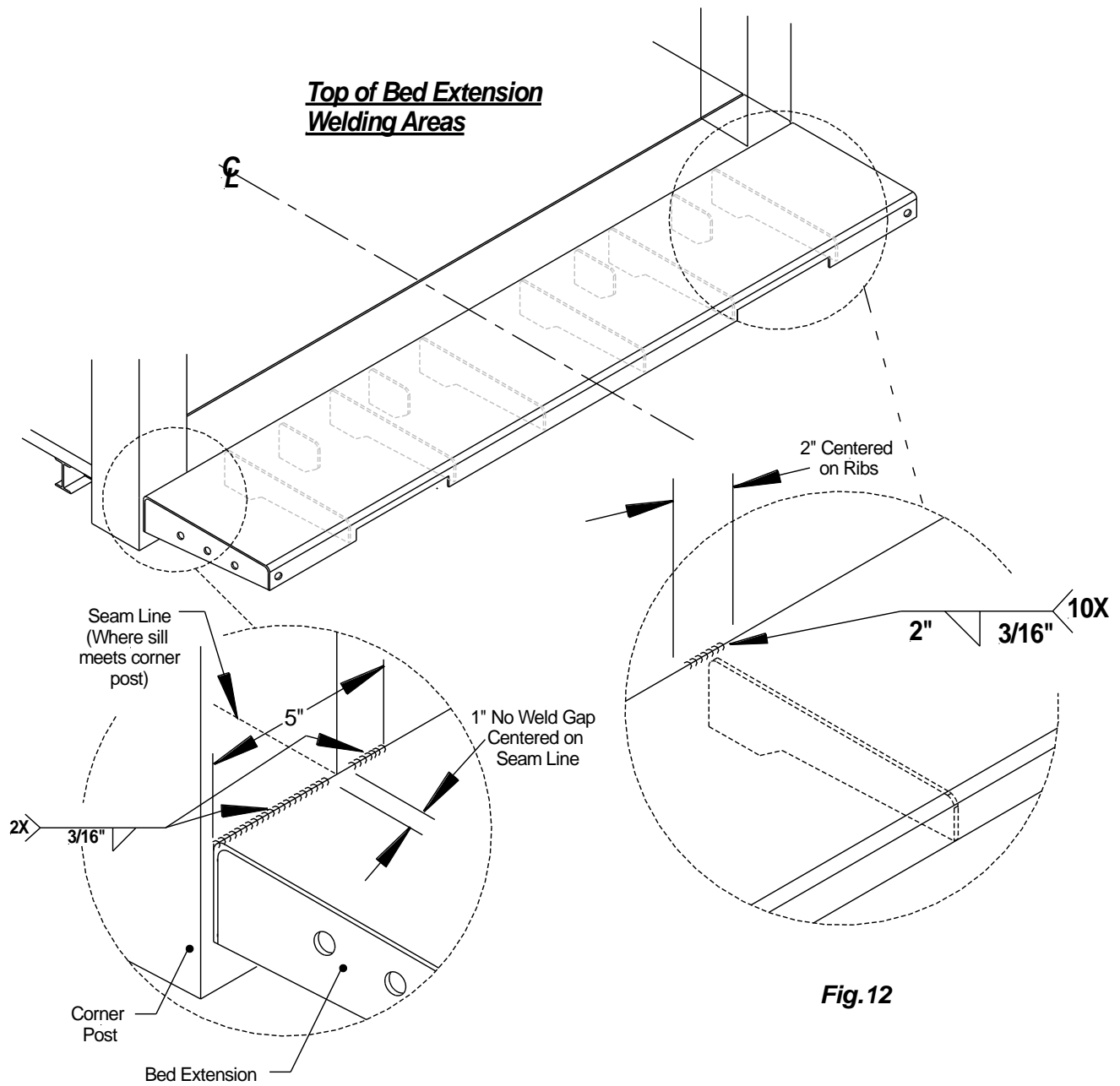

Fig.11

Fig.12

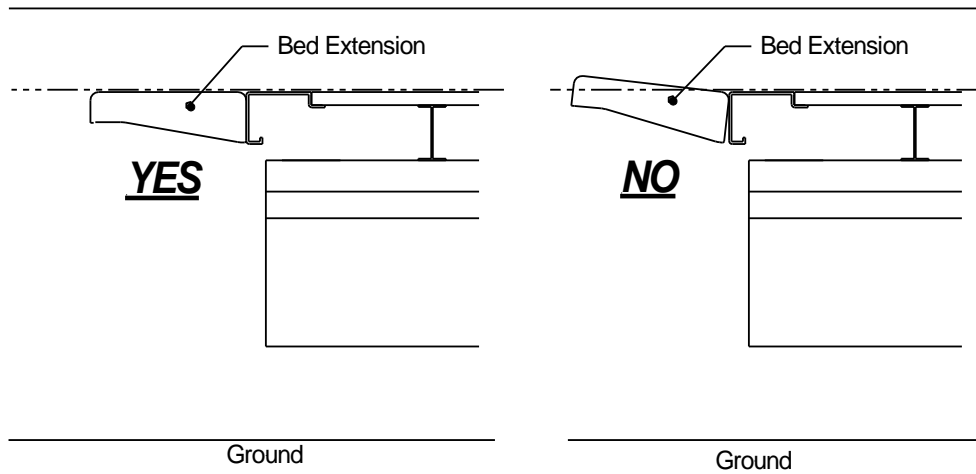
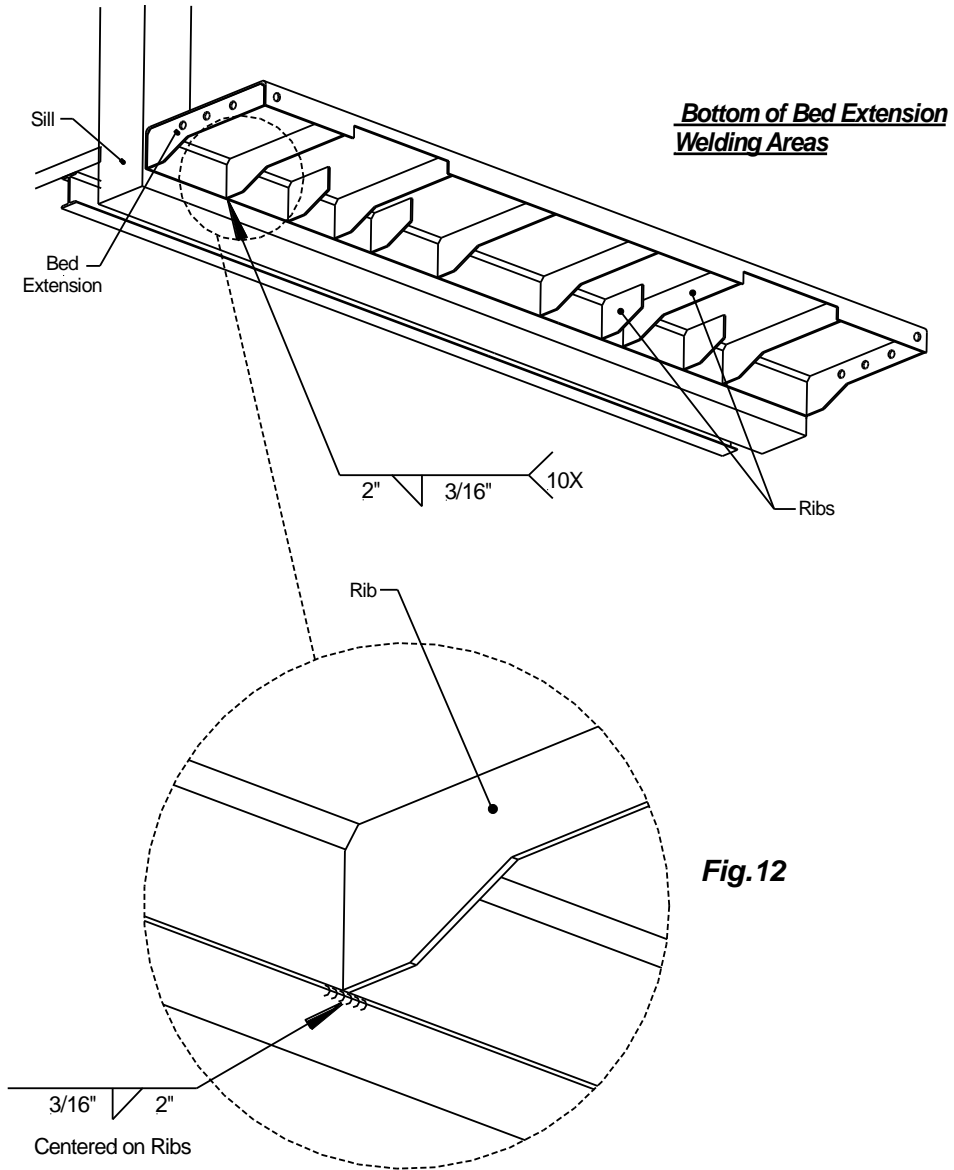
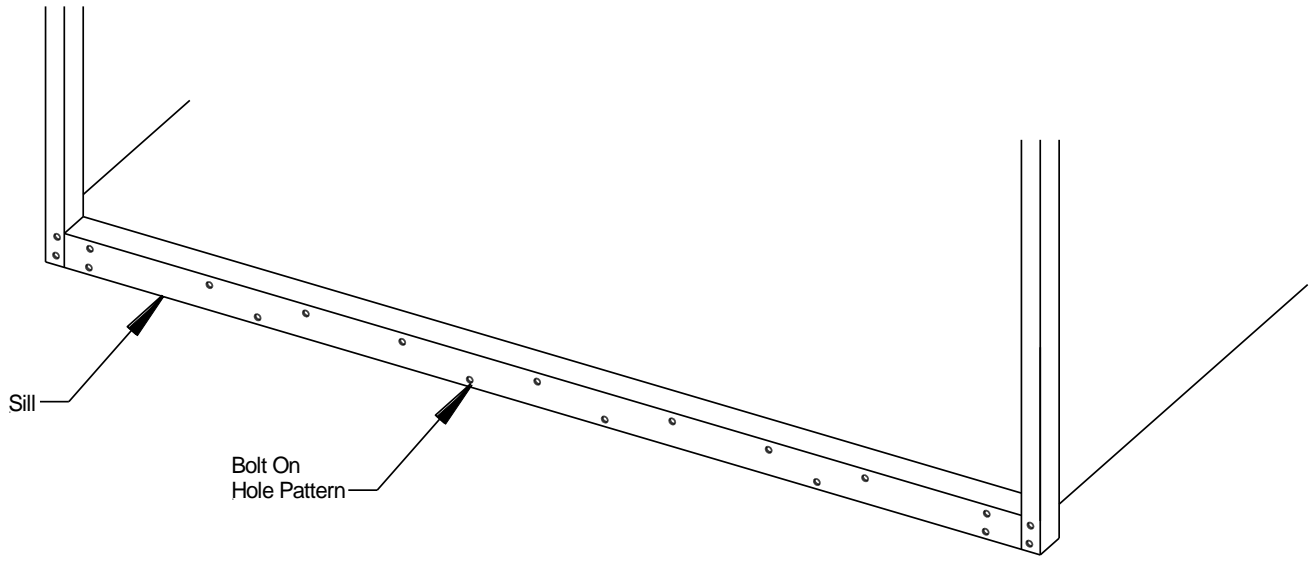
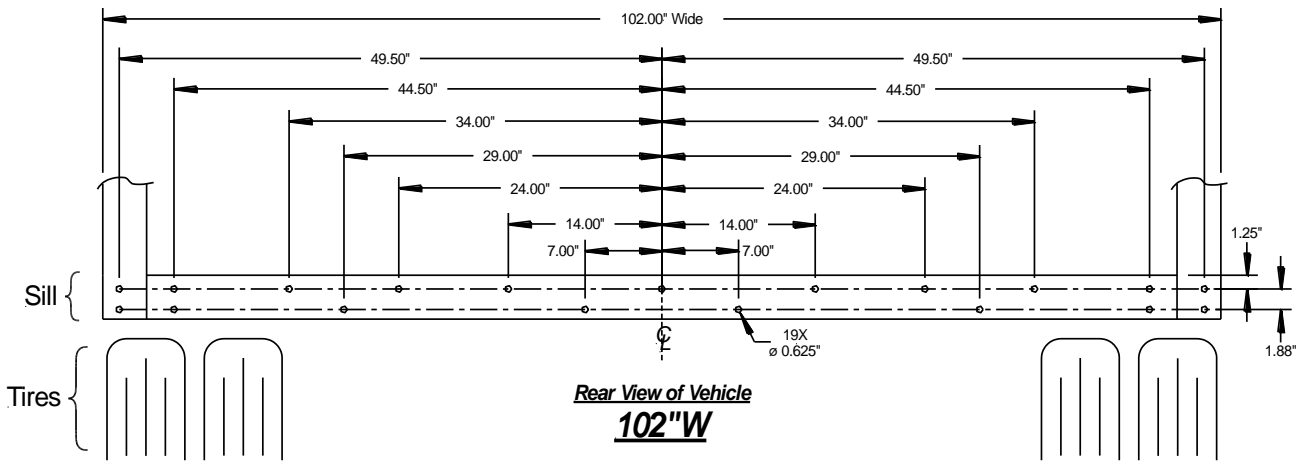
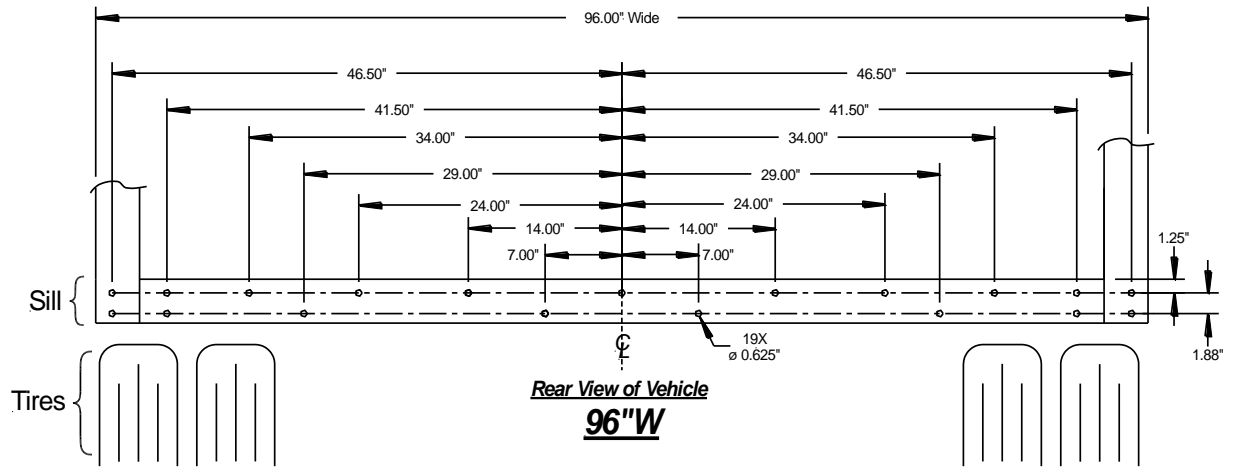

Fig.13

11.2 Bed Extension (Bolt-On)

1. Determine the vehicle width, 96" wide or 102" wide. Pre-drill 19, 5/8" holes on the rear of the sill. Follow the dimensions below.



2. Use a forklift, hoist or equivalent to support the bed extension and align the bed extension with the pre-drilled hole pattern on the sill. Verify the bed extension is squared. Secure the bed extension to the sill with the provided 9/16 x1.75" bolts and 9/16" nuts. Torque all bolts to 125 ft./lbs. min., 145 ft./lbs. max.

Recommendation: It is highly recommended to lubricate all bolts and nuts prior to installation.

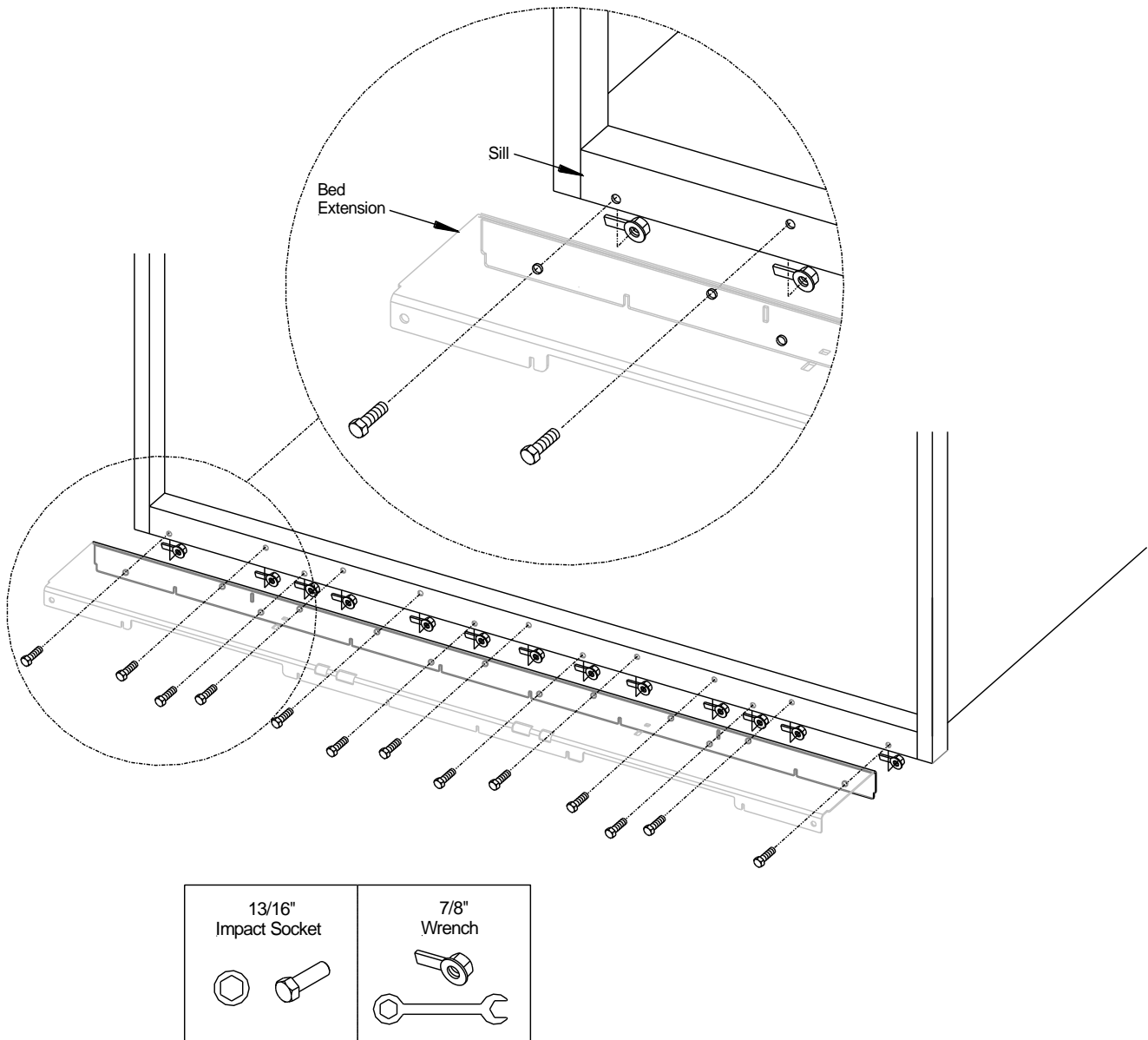

Bolt-On Bed Extension

12 Liftgate Installation (Truck)

12.1 Liftgate Installation

⚠ WARNING

Never work under platform without safety supports

CAUTION

High heat from welding can damage components within the heated area.

Steps:

1. Hoist Platform: Unfold platform manually and clamp forklift forks, overhead crane or equivalent to platform. Make sure the platform is secured. Always maintain the mount tube centered to the vehicles body. Make sure the tip of the platform is pitched up 2" and the platform is centered to the bed extension, **Fig 14**. **Important: Verify the retaining bolts or welds, on both sides, are in place securing the mount frame and swing fixture prior to beginning installation, Fig 15.**

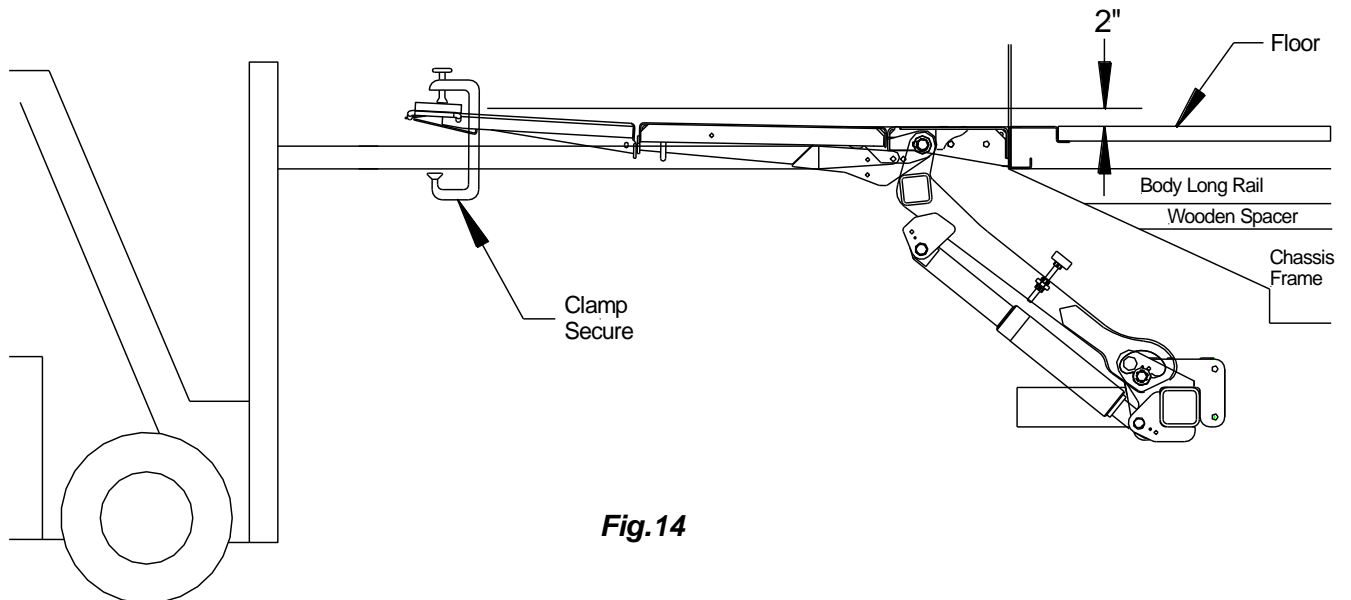

Fig.14

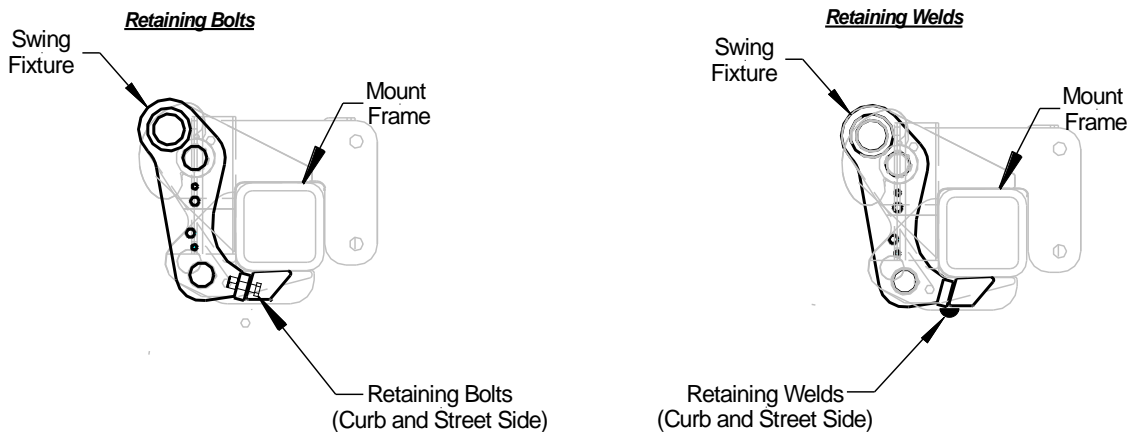
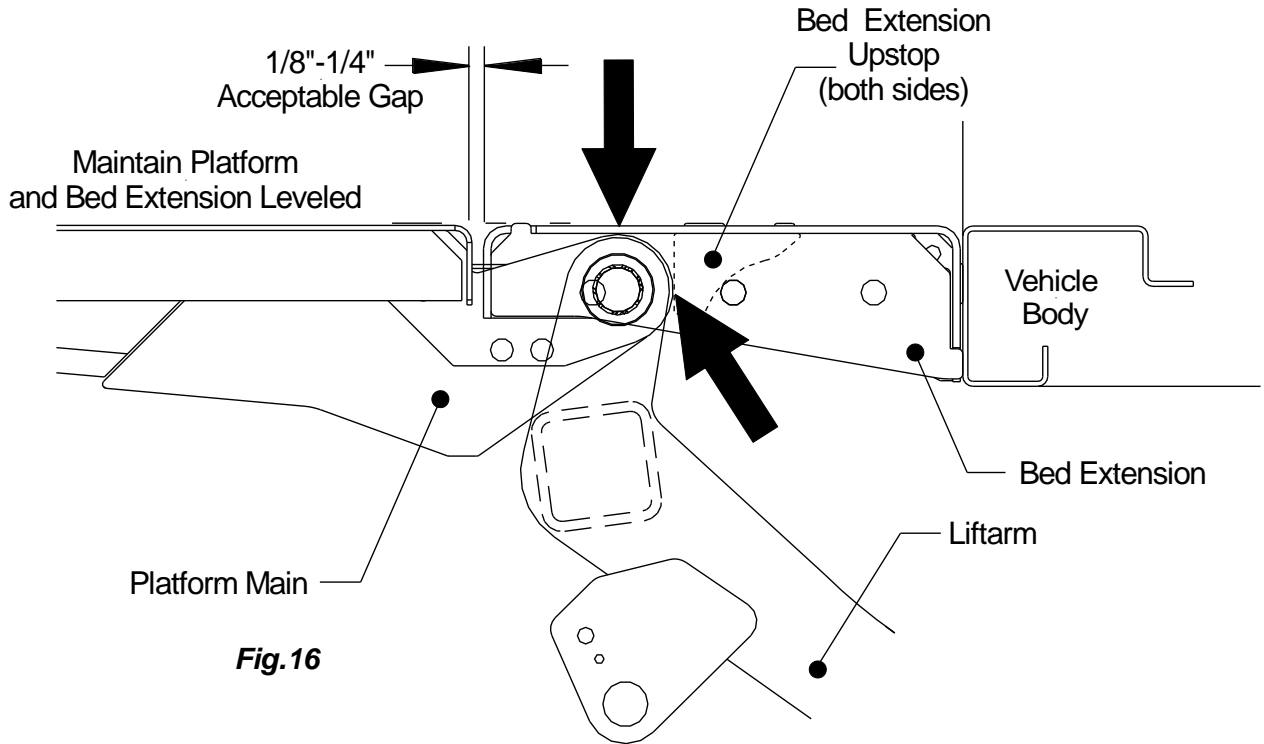

Fig.15

- 1a. Maneuver the liftgate under the vehicle and position both liftarms flush to both the bed extension upstops and the underside of the bed extension. Measure the gap between the bed extension and platform to confirm the gap is within the acceptable range, **Fig.16**.



- 1b. **Clamp Platform:** Clamp 3" channels over the bed extension and platform on the street side and curbs side of the bed extension so the relationship between the bed extension and platform is locked and maintained throughout the installation procedure, **Fig.17**.

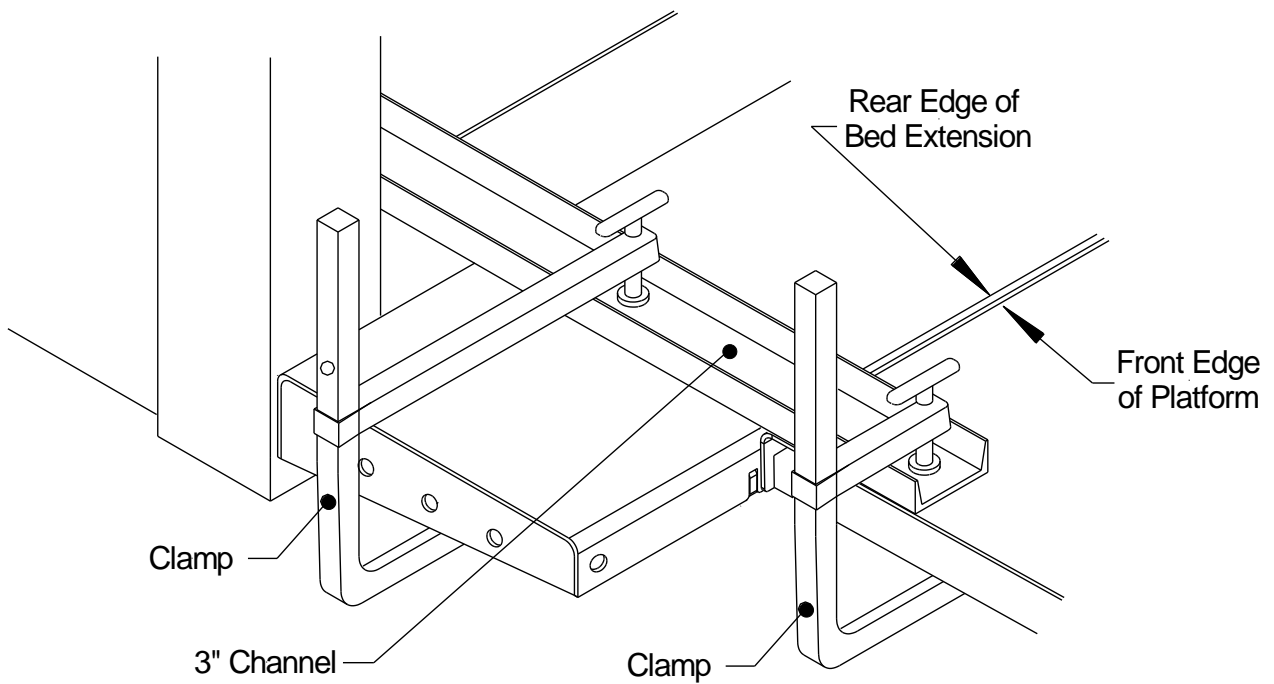

Fig.17

1c. Verification: After clamping platform, verify and confirm the following before proceeding: **Fig.18**.

- ① Bed extension and Platform are even.
- ② Both liftarms are flush with bottom of bed extension.
- ③ Both liftarms are flush with bed extension upstops.
- ④ Both shackles are flush with platform stop bolts.

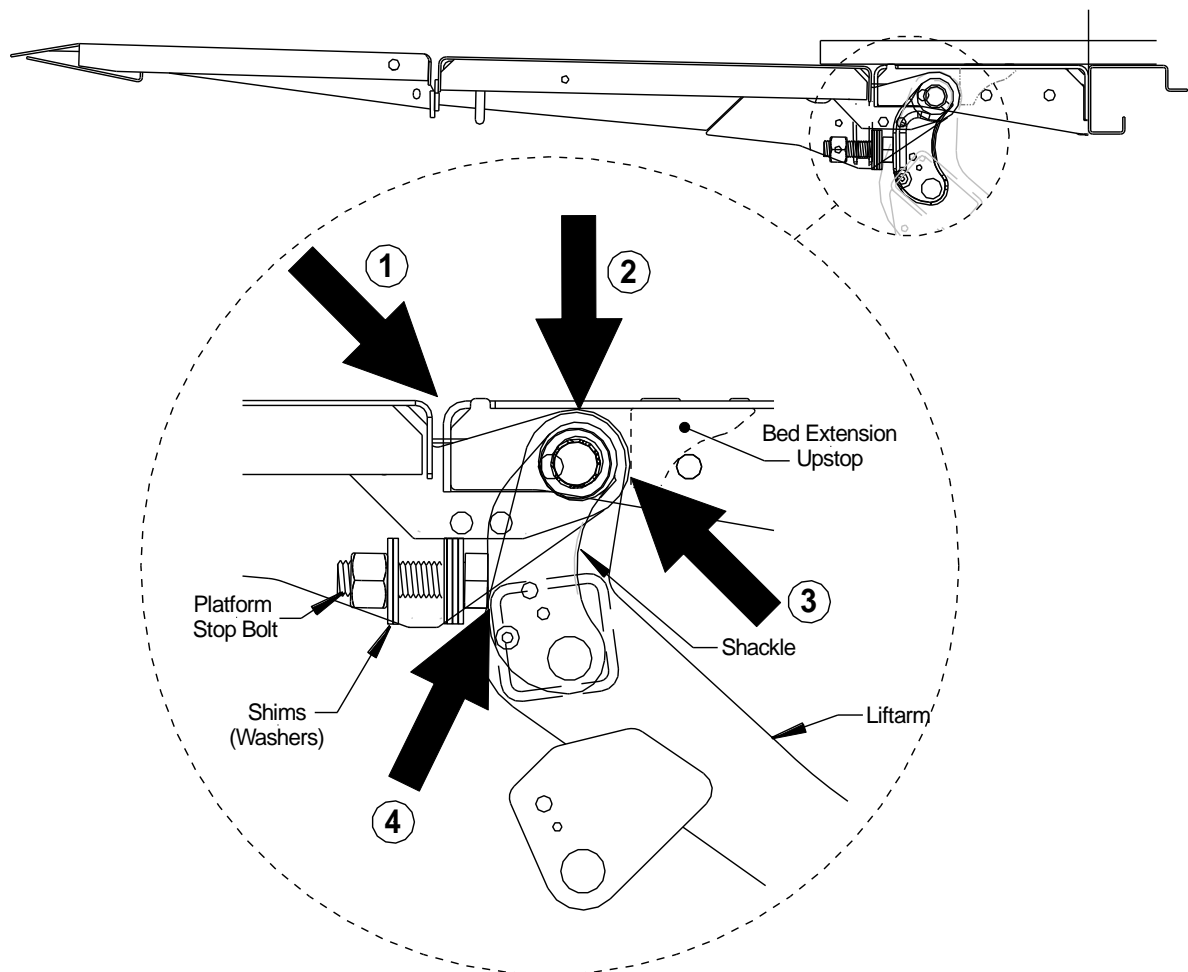
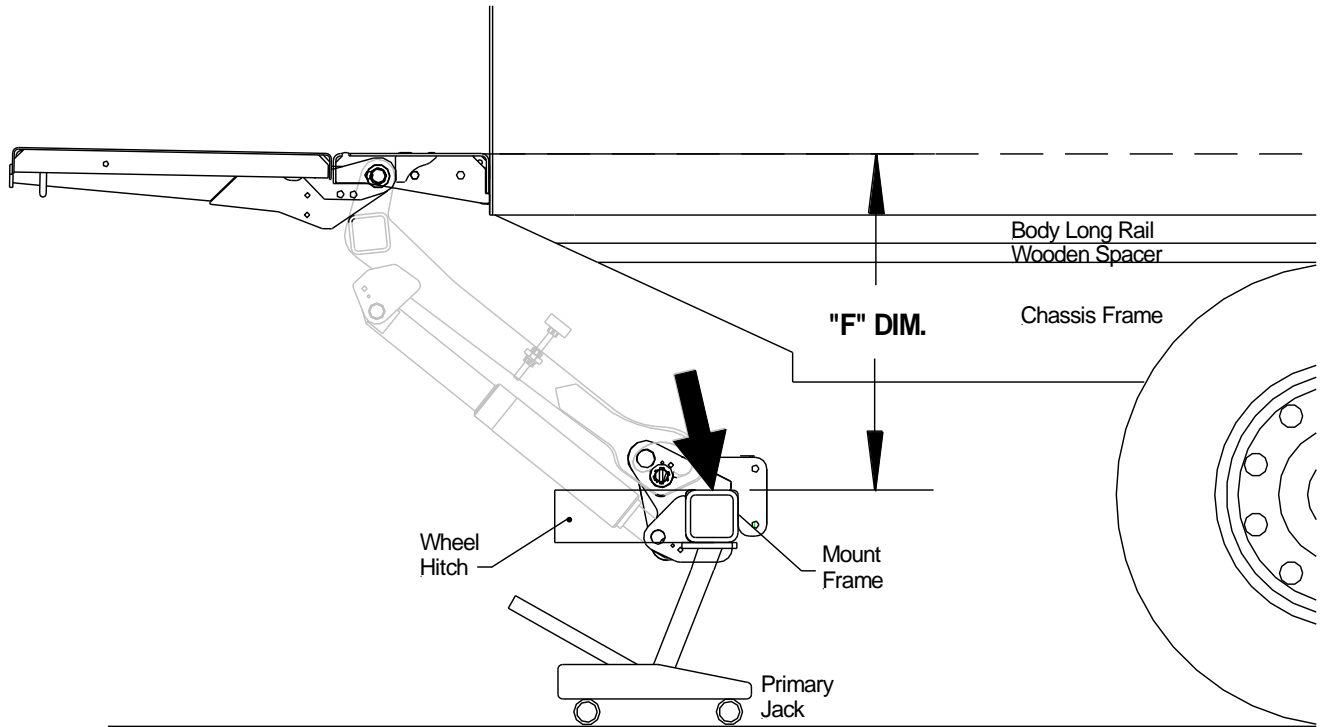

Fig.18

2. **Set "F" Dimension:** "F" Dimension should be determined from Sections 8 and 9 of this manual. Use a floor jack or equivalent to set the mount frame to the required "F" dimension, **Fig.19**. Use a second jack to level out roll off wheel hitch, if necessary, **Fig.20**. Check for squareness vertically and horizontally. 12V power supply may be required to release pressure on lift cylinder valve(s), if power is required continue to the Electrical Installation in Section 13.



Set F-Dimension

Fig.19

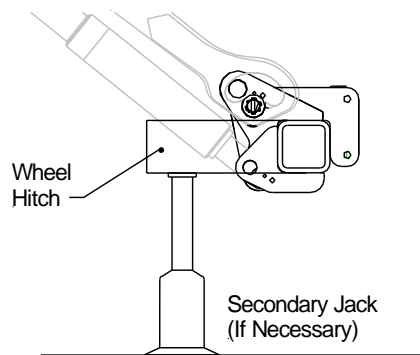
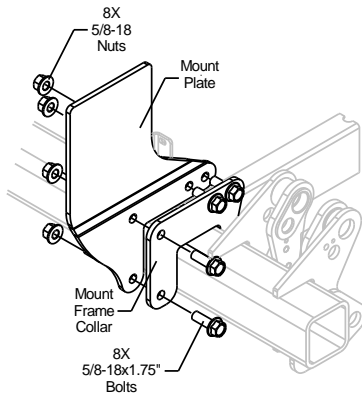
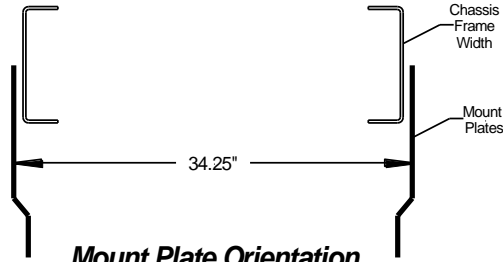

Fig.20

3. **Bolt-On Mount Plates:** Determine the width of the chassis. Orient the mount plates as indicated for that specific chassis width. Assemble the bolt-on mount plate to the mount frame collar with the 5/8-16 hardware. Torque bolts to 180 ft./lbs, **Fig. 21**.

Chassis Frame Width: 34.00"



Chassis Frame Width: 33.50"

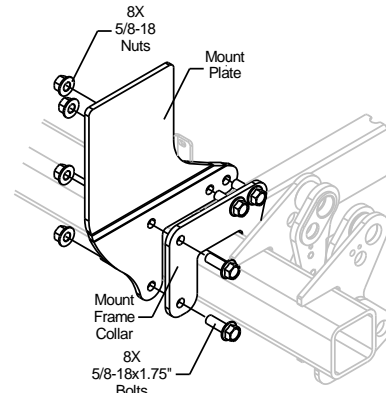
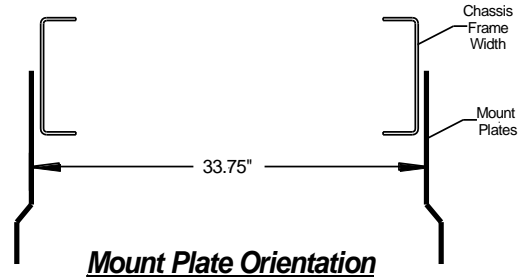

Chassis Frame Width: 33.00"

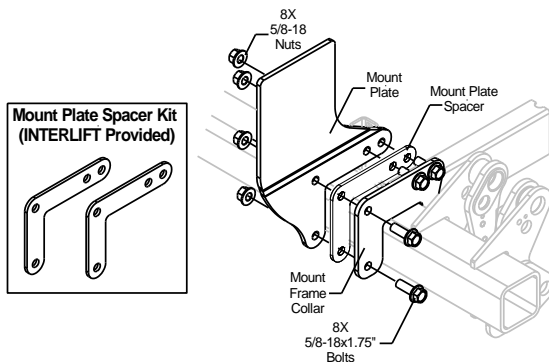
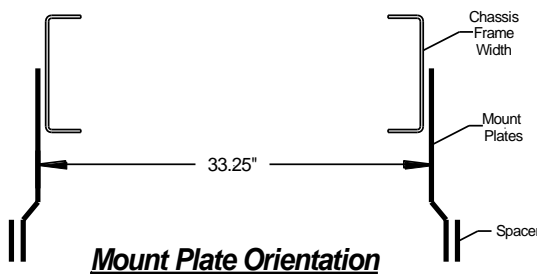

Chassis Frame Width: 33.00"
Optional

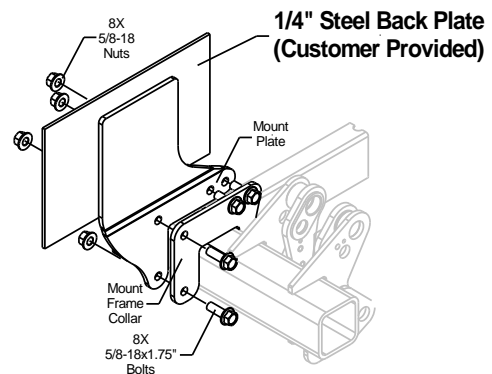
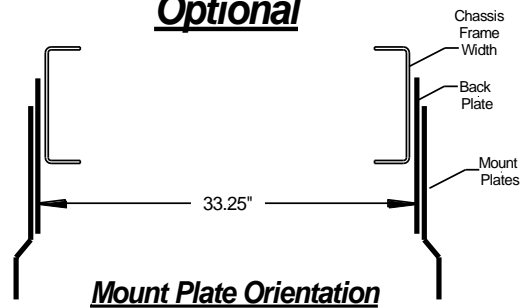

Fig.21

Weld on Mount Plates (Tack): Make sure the mount plate is squared to the mount frame tube vertically and horizontally. Install the mount plate to the chassis and tack weld using three fillet welds, 2" long on each side and on top of the mount plate. Connect the body long rail to the mount plate by adding an extension plate, when necessary, **Fig.22**.

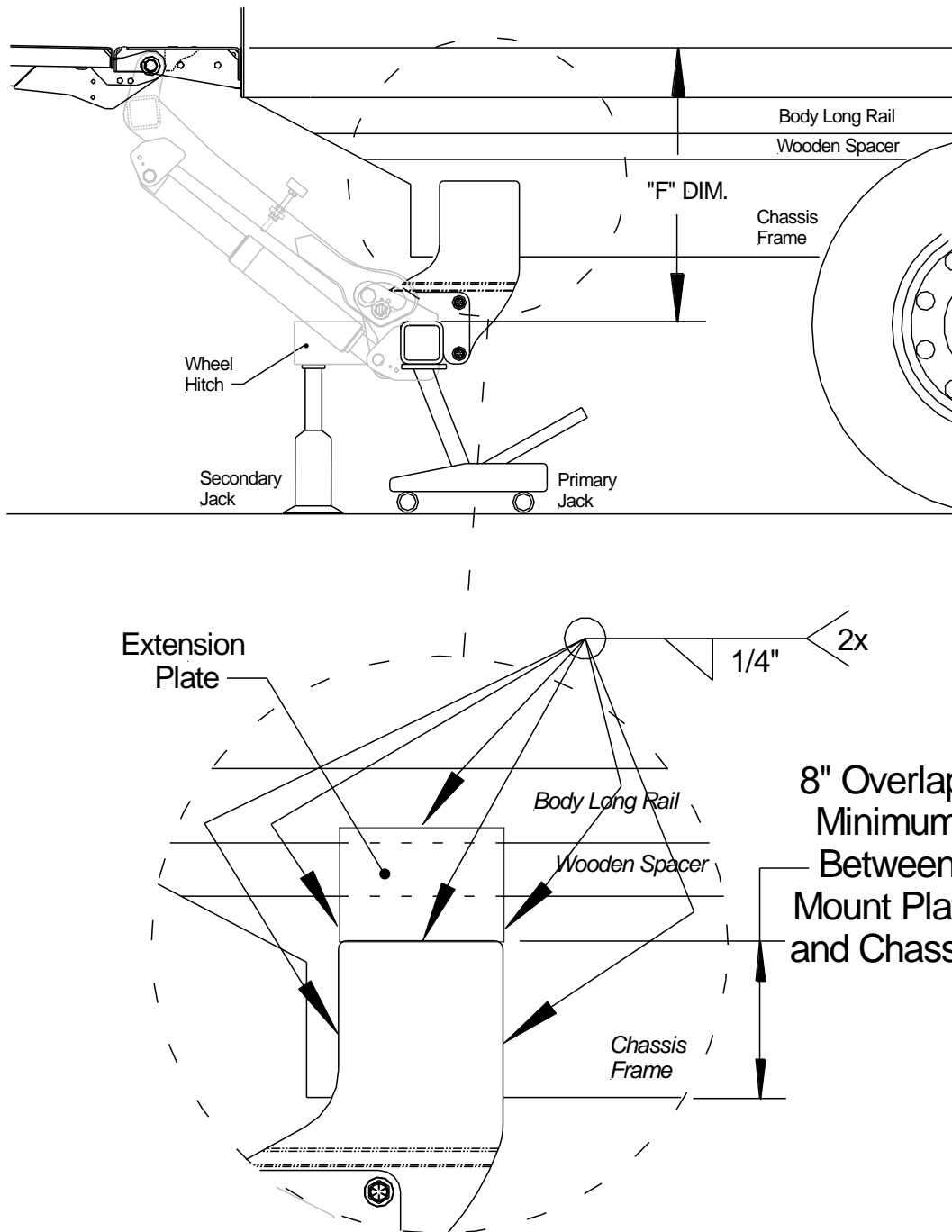

Fig.22

Weld on Mount Plates (Verify): Verify the following: One, F dimension has not changed. Two, bed extension and platform are still squared prior to tack welding the mount plates, **Fig.23**. Three, gate is operating as intended. **Do not power gate hard against bed extension while gate is only tack welded in position.**

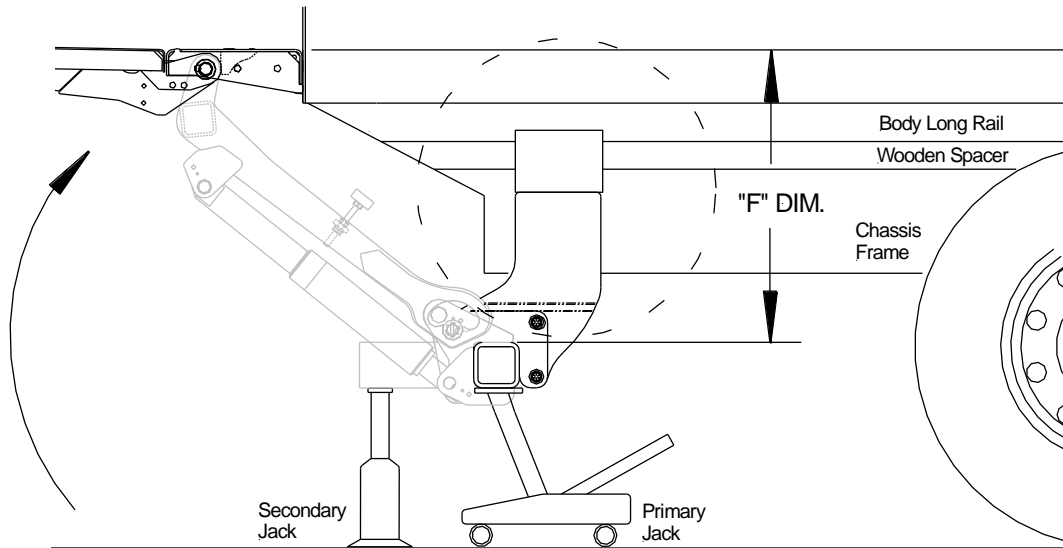

Fig.23

Weld on Mount Plates (Finalize): After verification continue to 100% welding of the mount plate to the vehicle frame and mount frame, **Fig.24**.

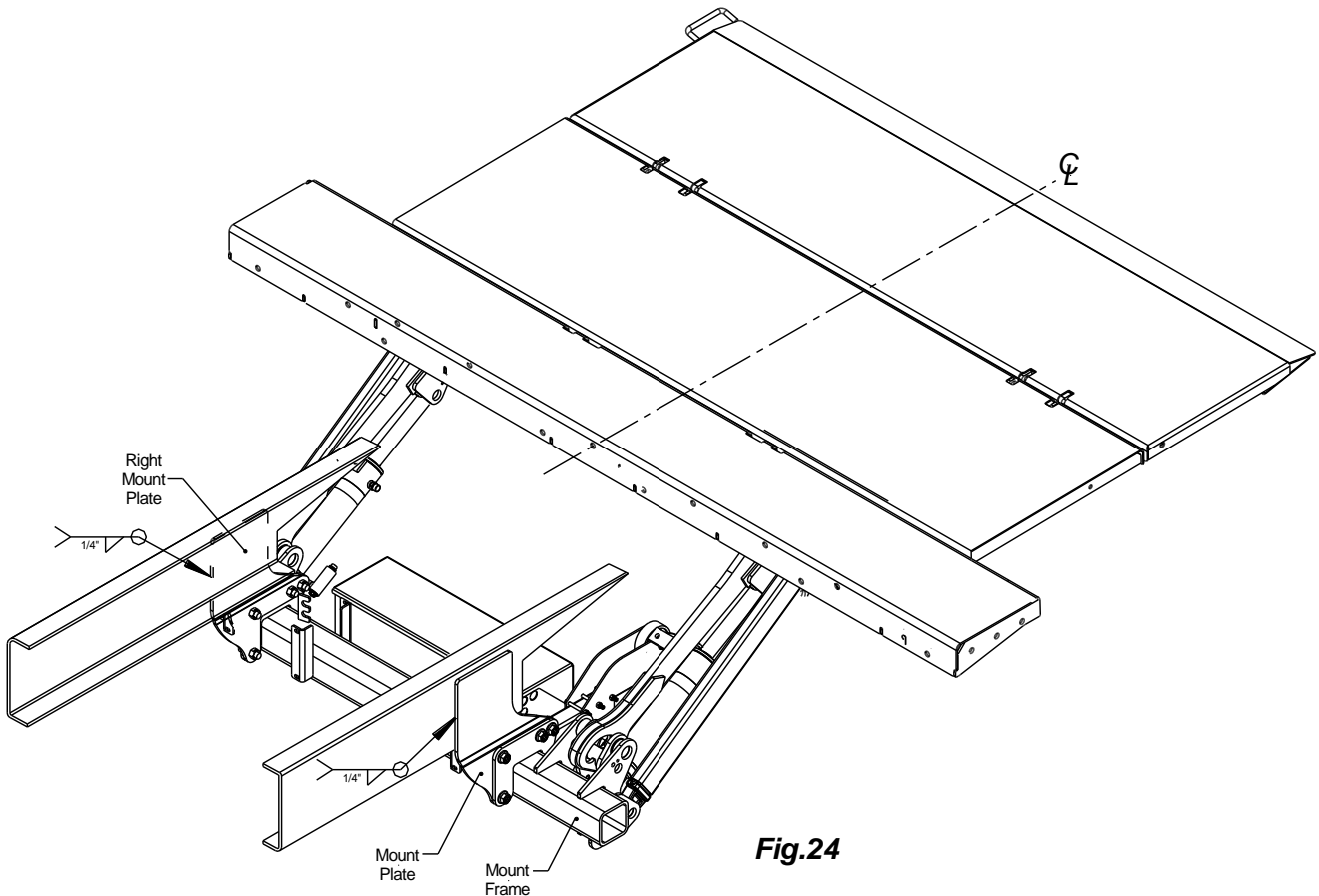
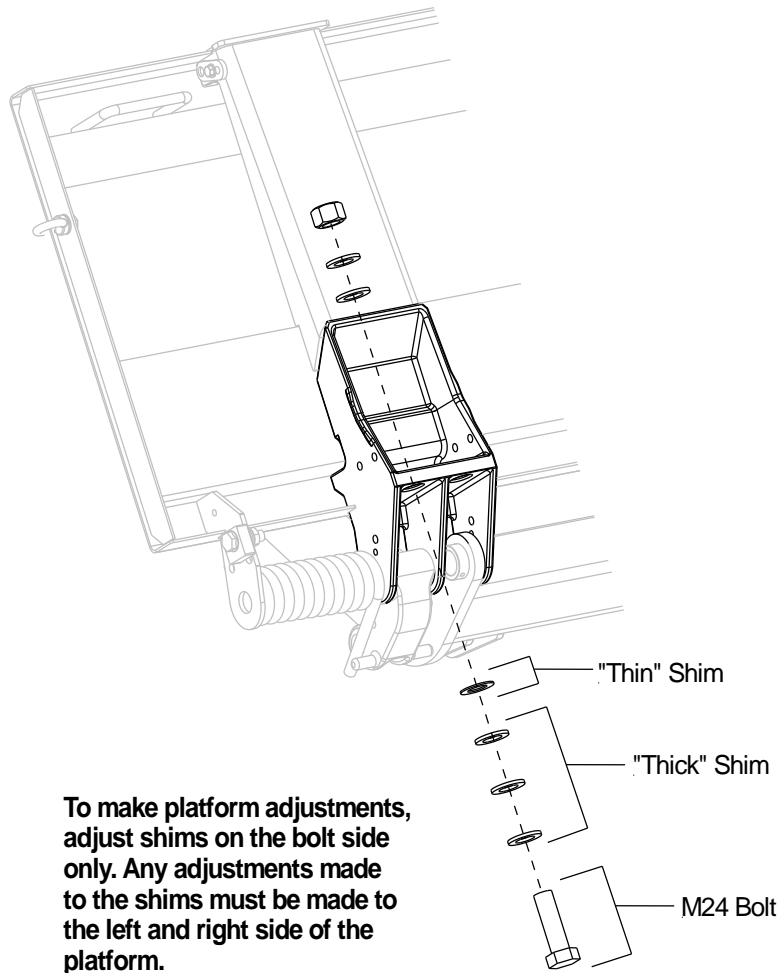

Fig.24

4. **Platform Adjustments (if necessary):** Adjustments of the liftgate are not required when the installation procedure has been followed per this manual. In some cases, platform adjustments could be required as not every vehicle is identical and installation variables differ from install to install.

The platform is equipped with a combination of “shims” (washers) installed on the stop bolts. Removing a “thin” shim will adjust the platform pitch by approximately $5/8$ ”, and removing a “thick” shim will adjust the pitch by approximately $1-1/4$ ”. Making these adjustments will assist in making up for the different installation variables.



12.2 Adjusting the Platform

CAUTION

Platform is heavy, use caution while handling.

Adjustment of the torsion cam applies to all platforms (steel, aluminum, or steel/alum).

Steps:

1. Torsion Cam Installation: To change the amount of platform spring assist, position the gate as shown below with the platform resting on the platform roll-off wheels and shackles contact the ground, **Fig.25**. The adjustment cam is installed with no tension when shipped, **Fig.26**. Verify that the platform has a curb and driver side cam.

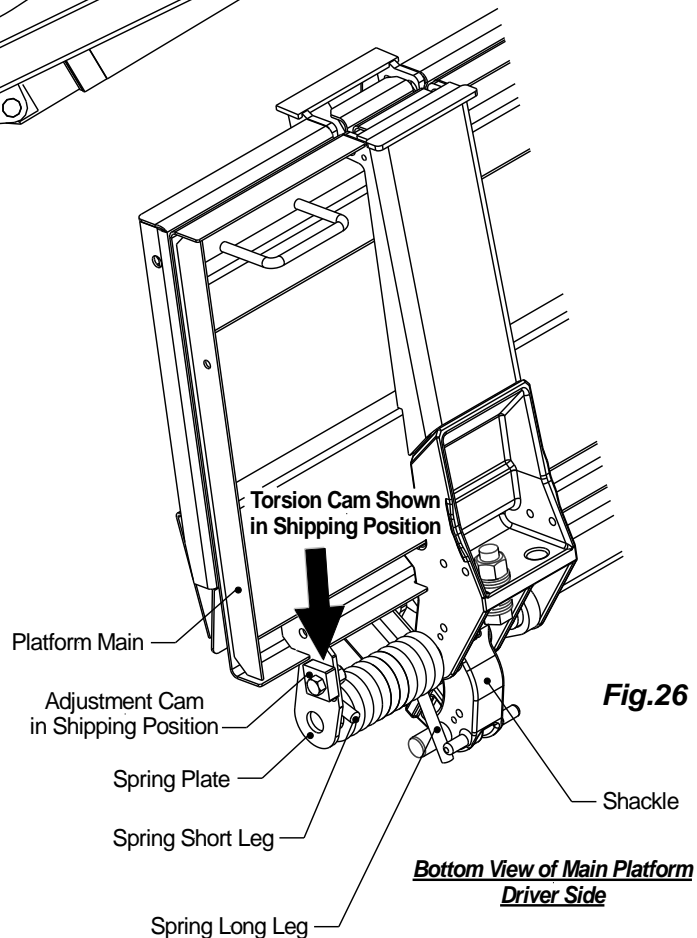
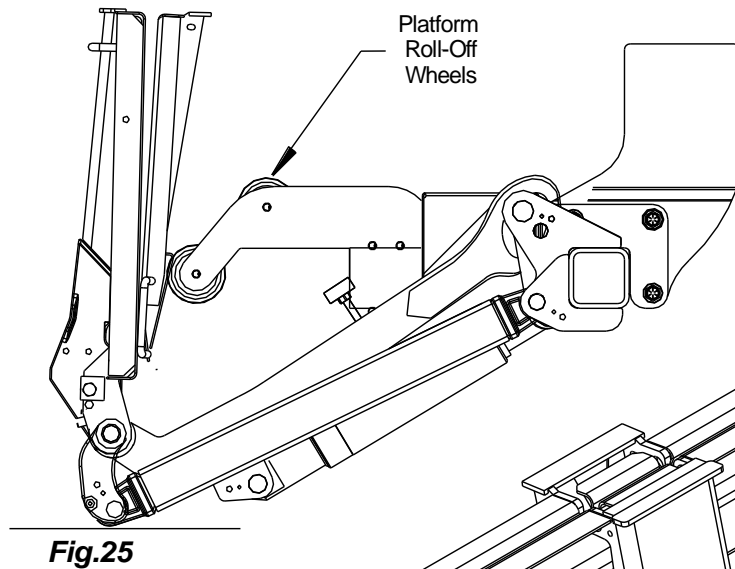

To add tension to the torsion spring, remove the adjustment cam from its shipping position, **Fig.27**. Next, install the cam on the inside part of the plate on the engaged position hole. The short leg of the spring should be in contact with the cam, **Fig.28**. Secure the cam with the bolt and nut. Torque the bolts to 100 ft-lbs, **Fig.29**. Repeat the process for the curb side cam. Make sure the driver side and curb side cams are installed on the same tension setting.

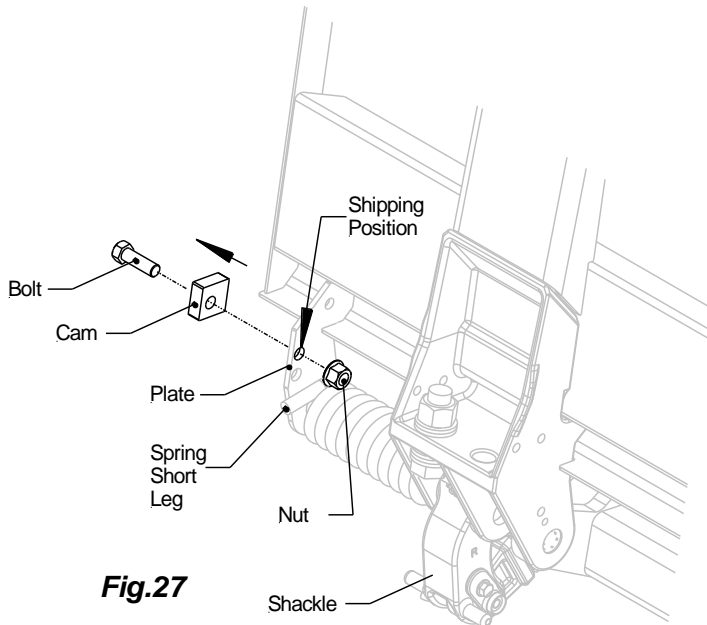

Fig.27

Removing Cam from Shipping Position

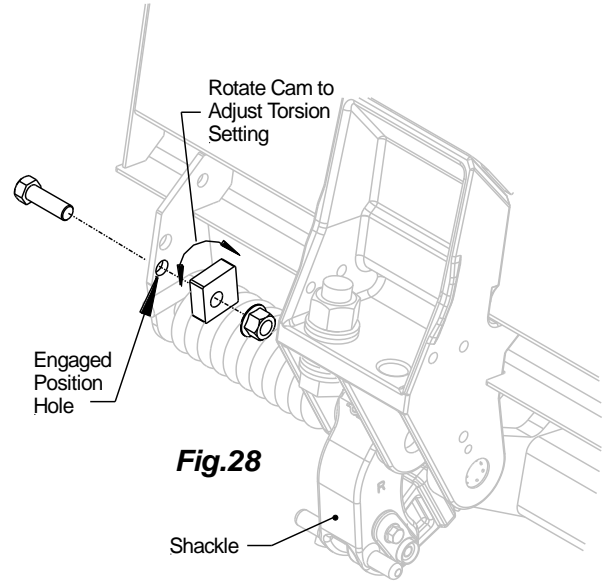

Fig.28

Cam Adjustment Inside of Plate

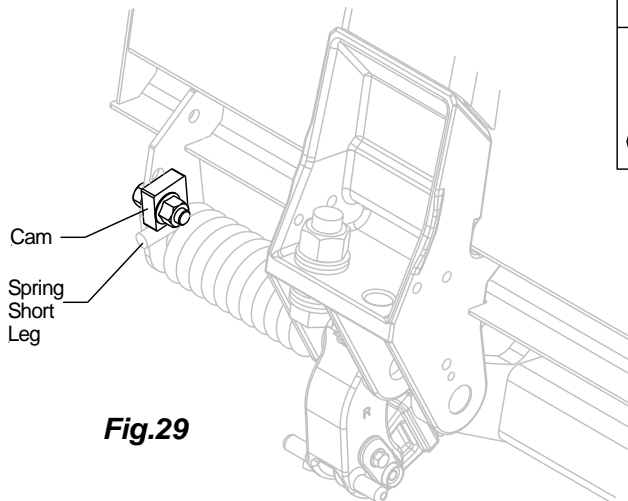
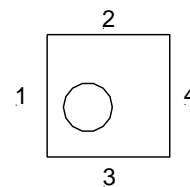
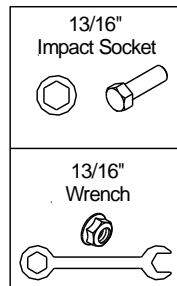

Fig.29



4 different torsion settings are possible after adjusting the cam.

Tension Settings:
 1 = Low Tension
 4 = High Tension

Torsion Settings for Aluminum and Steel Platforms:

Aluminum: Setting 2

Steel: Setting 4

2. **Adjust Sliding Wheel:** Loosen the nuts on the wheel bracket assembly. Adjust the wheel in or out along the wheel hitch until the platform is 5° inward. Once the wheel assembly is in set position, secure the wheels by torquing the six bolts to 16-20 ft/lbs. Note: Low vehicle bed heights will require more than 5°.

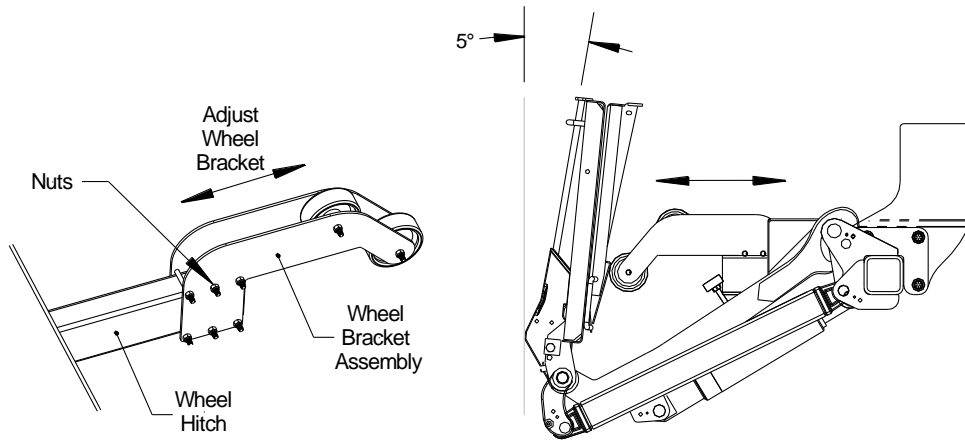

3. **Adjustable Rubber Snubber:** Adjust (2) rubber snubbers up to force the platform up against frame caps to hold platform from bouncing while vehicle is moving. Make sure there is a 1/2" gap between the frame cutout and the platform. Also make sure the rubber snubbers are adjusted so the gate does not rub on other components during the opening and closing sequences.

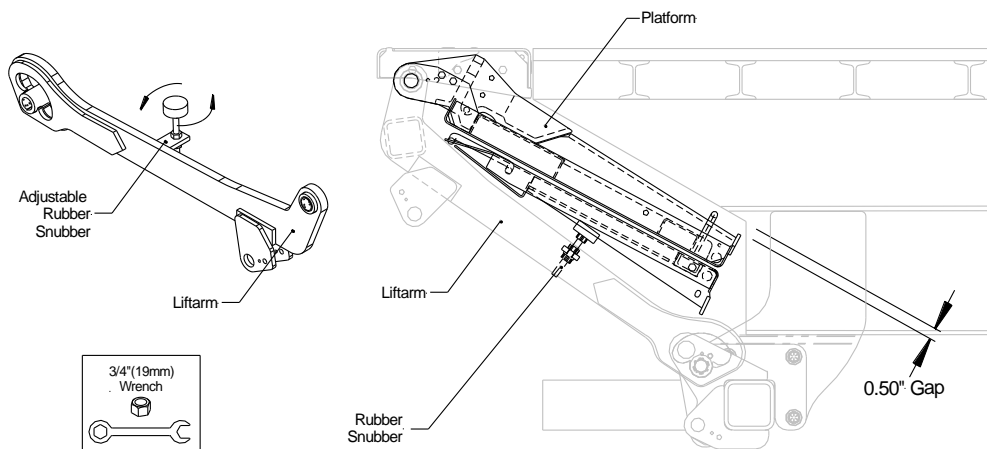

Use a 3" channel (each side) as a platform store stop where frame caps cannot be installed.

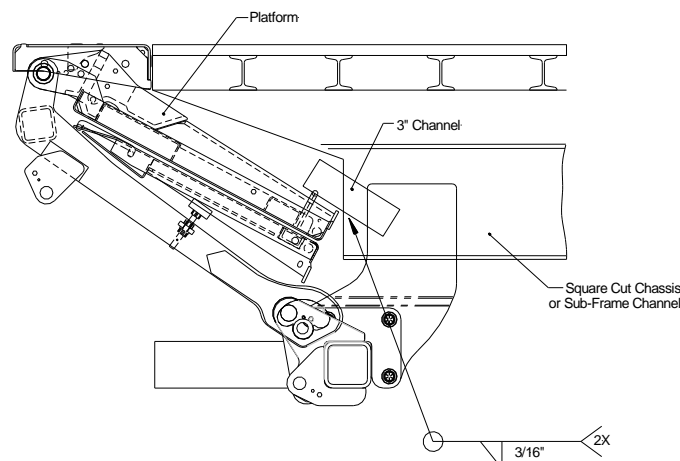

4. **Frame Cap:** Cap both frame cut outs with two pieces of 1/4" flat bar and two 2"x3"x3/16" angles. Install the 2" side of the angle on the outside of the frame. Weld components to the chassis and the body long rail. Flatbar may not be required if the frame cut out does not have a step.

Note: INTERLIFT Liftgates does not supply cap materials. All material must be supplied by end users.

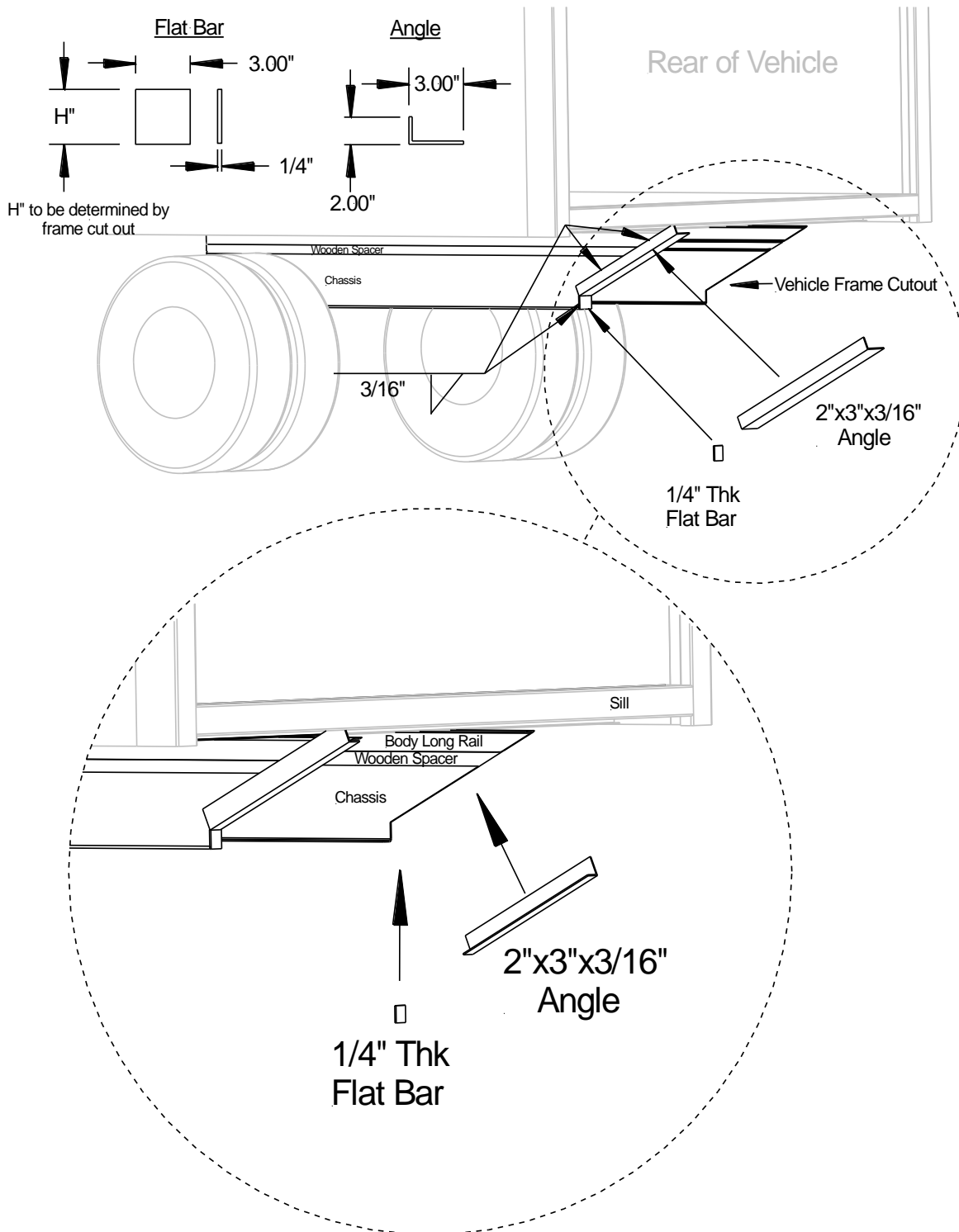

12.3 Final Steps of Installation

1. **Battery Connect:** Connect battery cable to batteries, aux batteries to power the liftgate. Refer to electrical installation on Section 13.
2. **Cycle Gate:** Cycle gate several times to assure proper alignment.
3. **Weld Gate:** Complete welding of gate. Weld all contact areas 100% with ¼” fillet welds.
4. **Remove Retaining Bolts and Welds:** Lower the gate down to the ground, and remove the retaining bolts or welds that hold the swing fixture fixed to the mount tube on curb side and street side.
 - 4a. **Removing Retaining Bolts:** Remove the bolt and nut from the left and right sides of the liftgate. Discard hardware, **Fig.30**
 - 4b. **Removing Retaining Welds:** Remove the welds to separate the swing fixture from the mount tube by grinding off the welds, **Fig.31**. Touch up any grinded surfaces with paint.

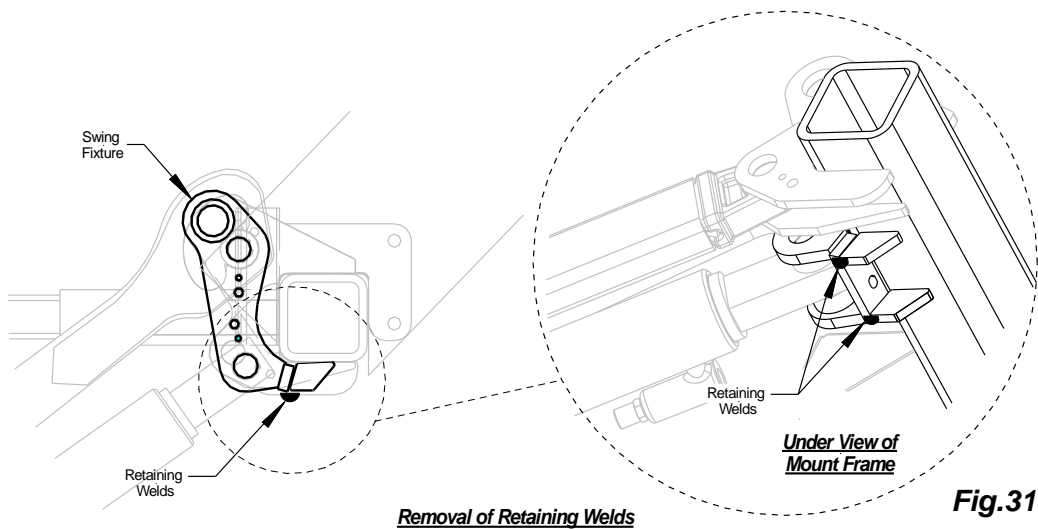
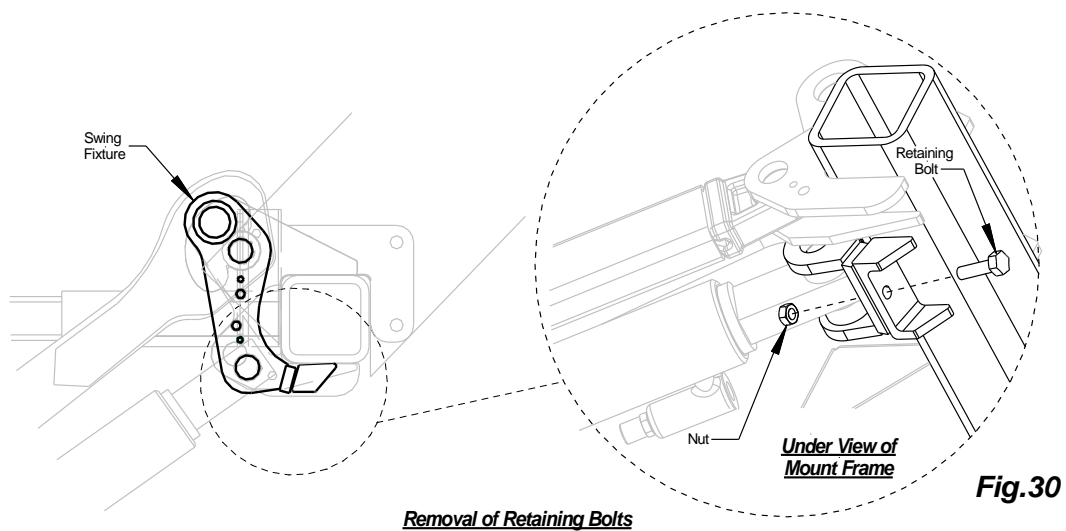

NOTICE

Platform will not tilt to the ground if the retaining welds or bolts are not removed.

12.4 Sub-frame Installation (Optional)

Trailer installations require a sub-frame to be installed prior to installing the liftgate.



Never work under platform without safety supports.

Steps:

1. Sub-Frame: Position the sub-frame channels up against the trailers crossmembers in the orientation shown below. Weld the sub-frame channel to multiple crossmembers. Use 3/16" welds to secure the sub-frame to a minimum of four crossmembers.

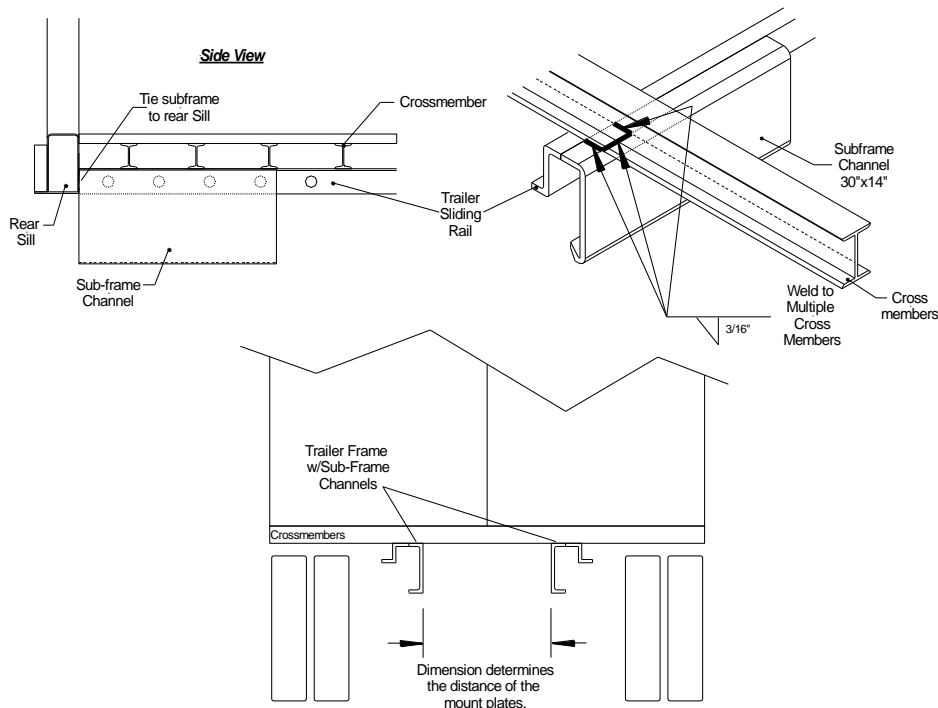

2. Support Plates: Install three support plates per sub-frame channel as shown and secure the plates with 3/16" welds.

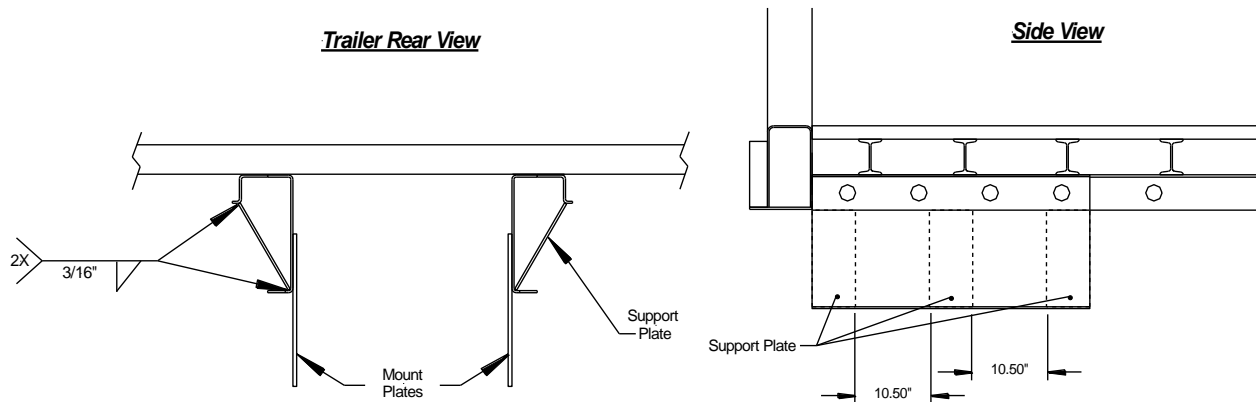

3. After installing the sub-frame, follow the installation procedure in Section 12 to complete the liftgate installation.

12.5 Dock Bumper Installation - Weld-On (Optional)

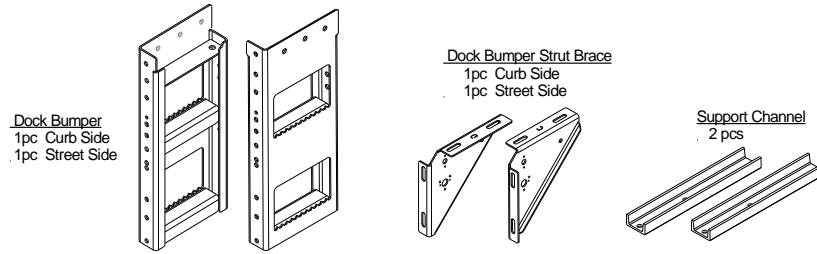

Steps:

- 1. Dock Bumpers:** Clamp dock bumpers to the bed extension as shown, **Fig.32**. Check for squareness. Tack weld the dock bumper. Repeat process for driver side

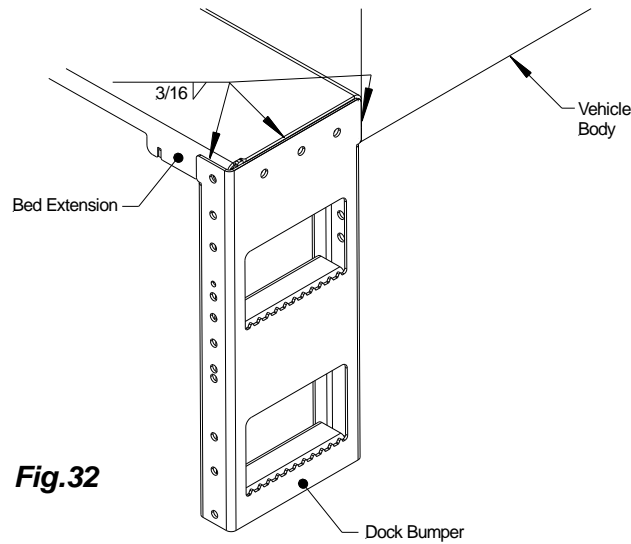

- 2. Dock Bumper Supports:** Each strut brace has a marking for easy identification, the curb side strut has a "C" marking and the drive side strut has a "D", **Fig.33**. Position the support channels perpendicular to a minimum of three of the vehicles cross members, move the channel horizontally for adjustment, **Fig.34**. Use clamps or similar devices to hold the support channels in place. Next position the strut against the dock bumper and support channel, clamp in place. Check for squareness. Finally, secure all components with 3/16" welds.

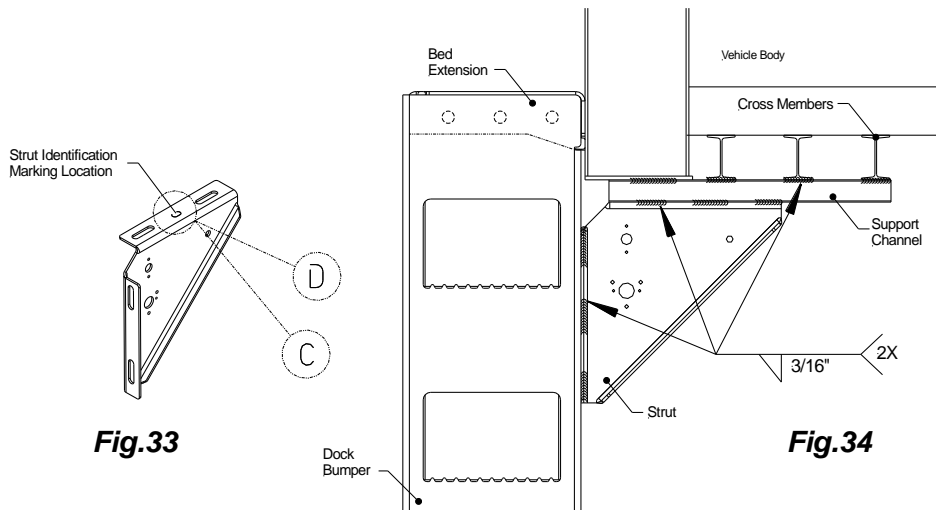

12.6 Dock Bumper Installation - Bolt On (Optional)

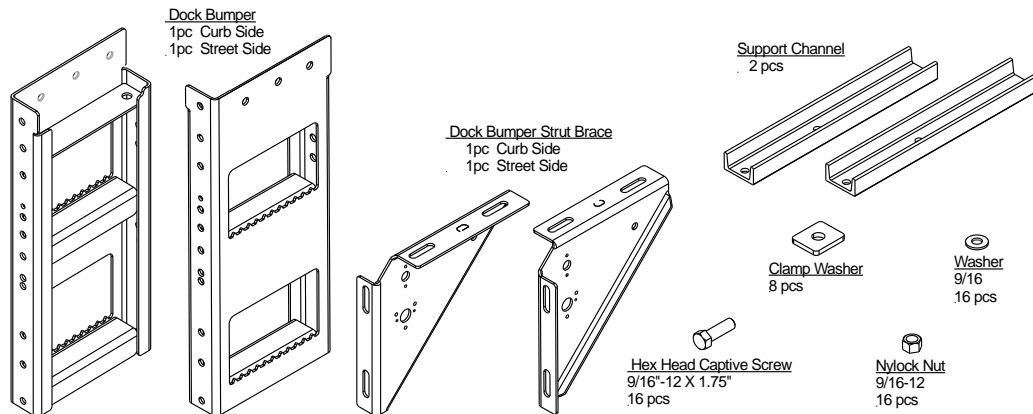

Steps:

1. **Dock Bumpers:** Use four (4) bolts and four (4) nuts to mount the dock bumper to the bed extension, **Fig.35**. Torque nuts to 125 ft. /lbs. minimum. Make sure the dock bumper is properly squared. **Recommendation: It is highly recommended to lubricate all bolts and nuts prior to installation.**

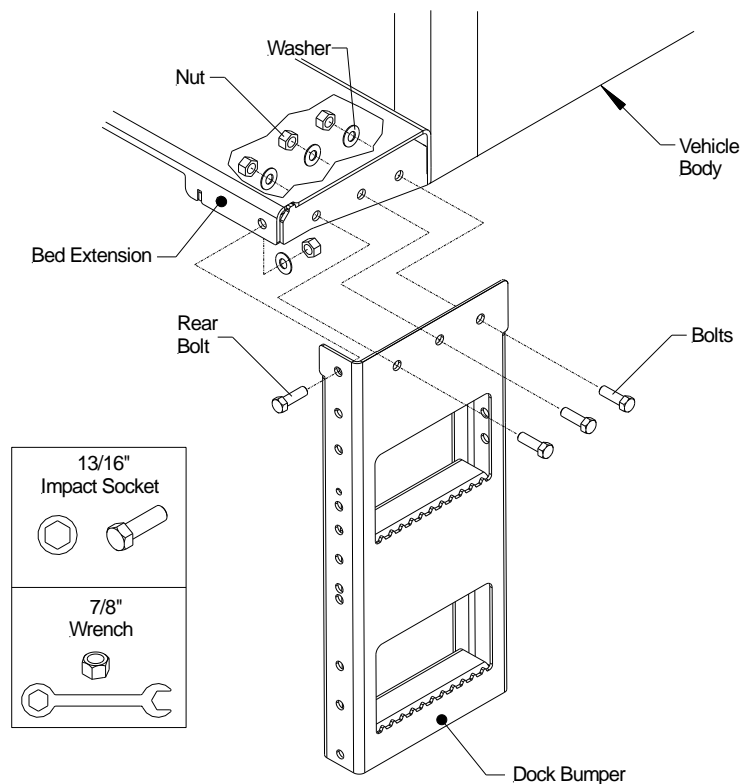
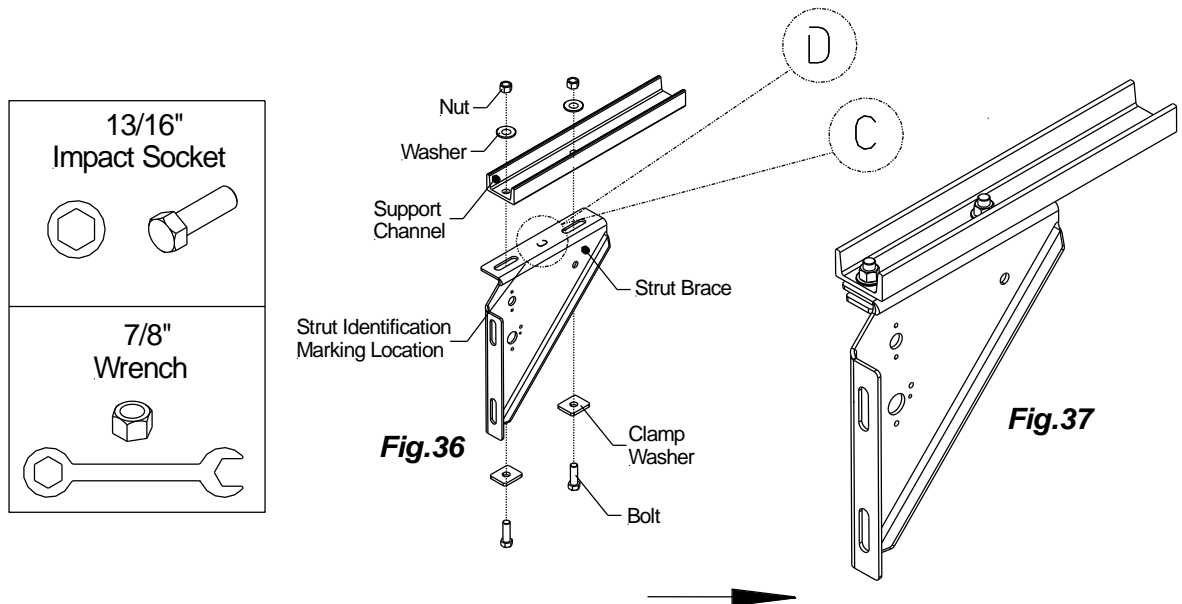

Fig.35

NOTICE

When installation requires a Walk Ramp kit, do not install the rear bolt. The bolt hole will be required to install the Walk Ramp Extension (reference Section 12.7).

2. **Dock Bumper Support:** Each strut brace has a marking for easy identification, the curb side strut has a "C" and the driver side strut has a "D", **Fig.36**. Join the support channel to the strut using a set of bolts, clamp washers and flange nuts, **Fig.37**. Do not tighten nuts completely as adjustment to the support channel could be required.



3. **Bolt Assembly:** Secure the strut support to the dock bumper with a set of bolts, clamp washers, and flange nuts, **Fig.38**. Adjust the strut brace by moving it vertically along the dock bumper and also the support channel, horizontally, along the vehicles cross members for best positioning. Check for squareness. After tightening all bolts in place, weld the support channel to the bottom of the vehicles cross members. A minimum of three cross members should be welded to the support channel, **Fig.39**. Torque nuts to 125 ft. /lbs. minimum

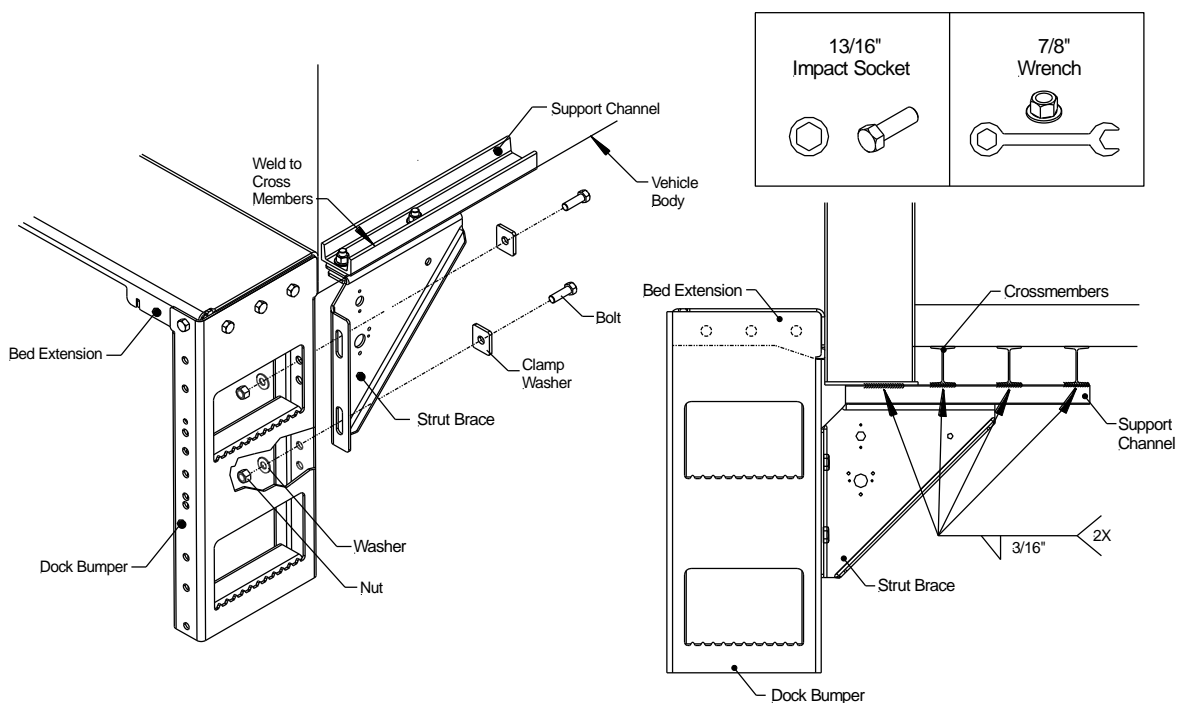
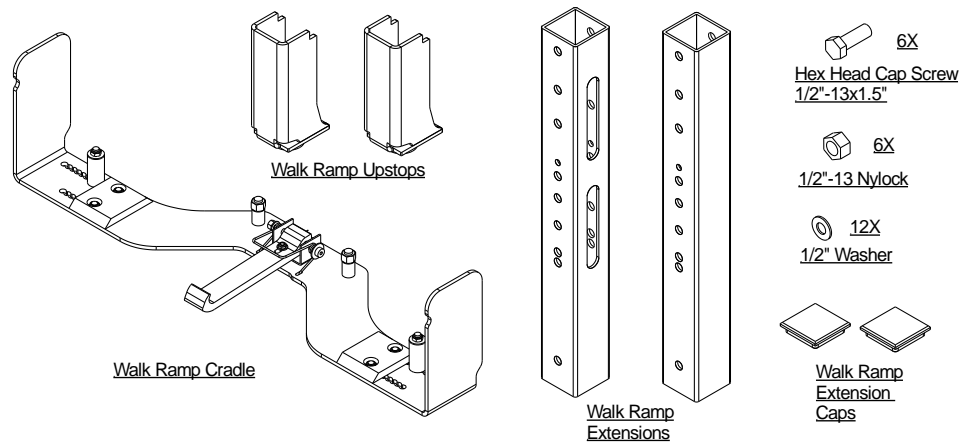

Fig.38

Fig.39

S

12.7 Walkramp Cradle Installation (Optional)



NOTICE

Walk ramp installations apply to the vehicle bed heights and platform sizes below, based on 4" vehicle sills. Vehicle bed heights are absolute minimum when the vehicle is fully loaded, gassed, and on even ground. It is highly recommended to start with 2"-3" higher for vehicle bed heights.

Walk Ramp Compatibility Tables

800mm [31.50] Liftarm		
Vehicle Bed Height	Platform Sizes	
	48"	54"
52"	✓	✓
51"	✓	✓
50"	✓	✓
49"	✓	✓
48"	✓	✓
47"	✓	✓
46"	✓	✓
45"	✓	n/a
44"	✓	n/a
43"	✓	n/a
42"	n/a	n/a
41"	n/a	n/a
40"	n/a	n/a
39"	n/a	n/a
38"	n/a	n/a

900mm [35.40"] Liftarm (Optimal for platform clearance)			
Vehicle Bed Height	Platform Sizes		
	48"	54"	60"
55"	✓	✓	✓
54"	✓	✓	✓
53"	✓	✓	✓
52"	✓	✓	✓
51"	✓	✓	✓
50"	✓	✓	✓
49"	✓	✓	✓
48"	✓	✓	n/a
47"	✓	✓	n/a
46"	✓	✓	n/a
45"	✓	n/a	n/a

n/a = not applicable

NOTICE

5" sill vehicles will need to add 1" to the vehicle bed heights in the compatibility tables above.

Steps:

1. **Walk Ramp:** Measure the walk ramp width. The walk ramp cradle has adjustable Slide Guards and Slide Pads to accommodate different widths of walk ramps. Adjust the slide guard and pad by removing the nut and sliding the guard/pad on both side of the cradle to the next available slot.

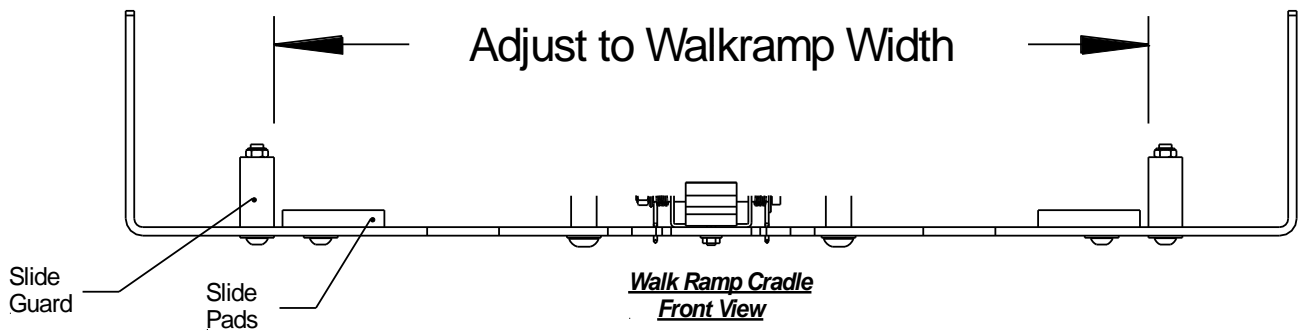
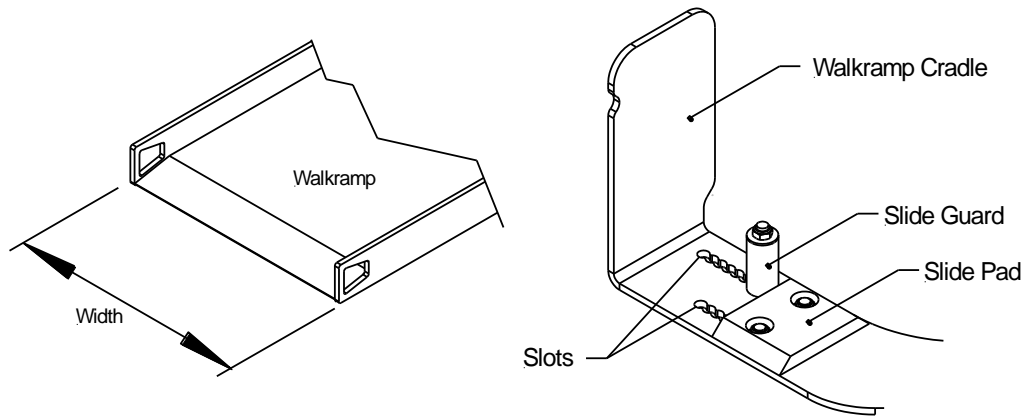

2. **Cradle Position:** Position cradle in the orientation shown below with the retainer hook pointing out. Slide the walk ramp cradle assembly between the two bed extension ribs and weld 100%.

NOTICE

4" Sill highly recommended for walk ramp application, especially on lower range of loaded (laden) dimension.

4" Sill Highly Recommended for Walk Ramp Application

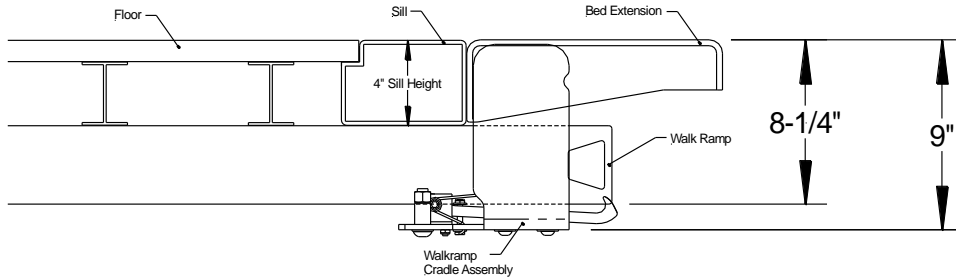

5" Sill Optional: Add 1" to bed height dimension from compatibility table.

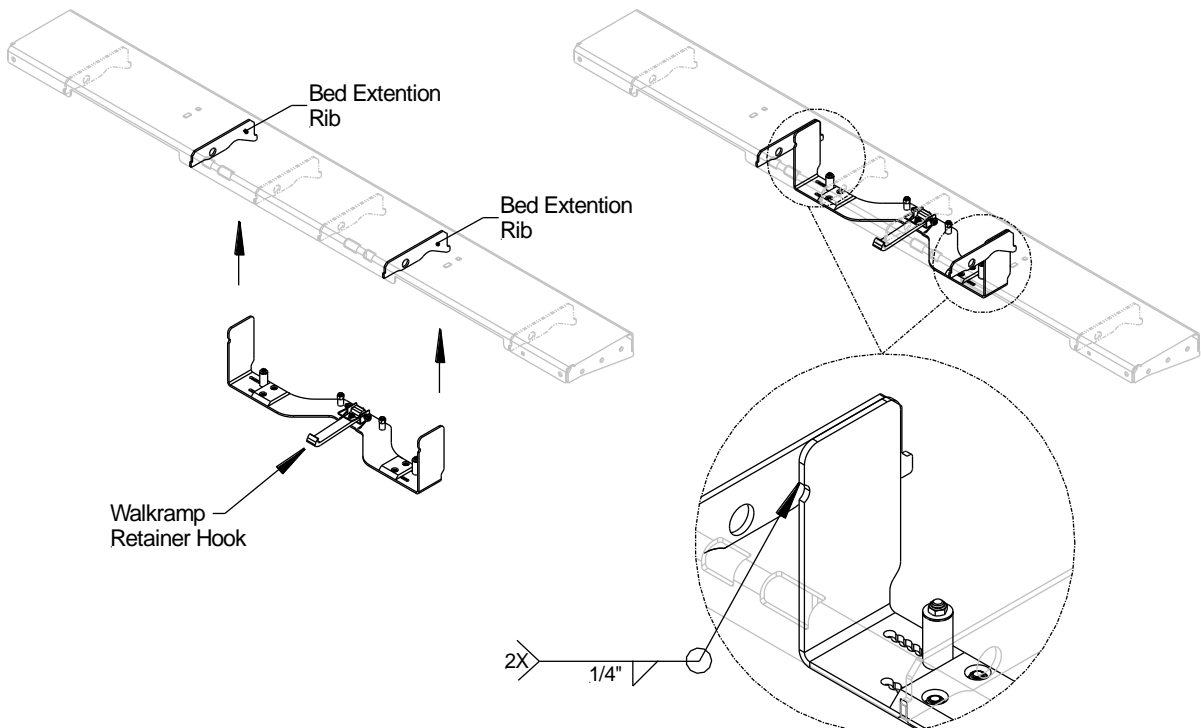
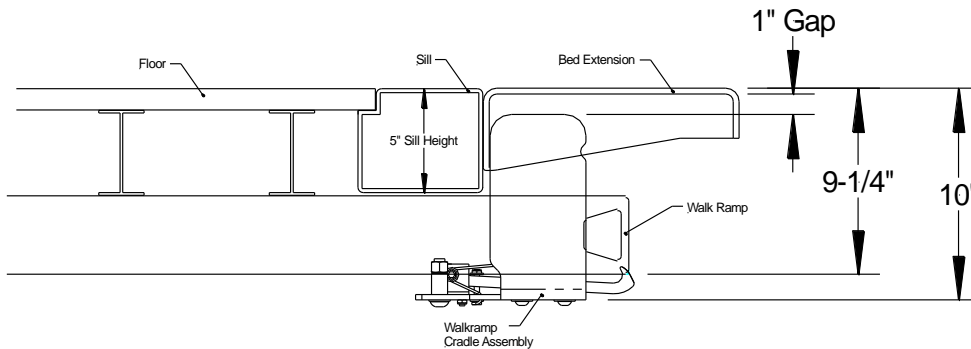

3. **Upstops:** Position the two upstops 7-3/4" from each side of the walk ramp cradle. Position the upstops up against the back side of the bed extension and weld 100%.

IMPORTANT! If the walk ramp cradle has been mounted lower, the upstops need to be lowered equally.

Front View of Bed Extension w/Walk Ramp Cradel and Upstops

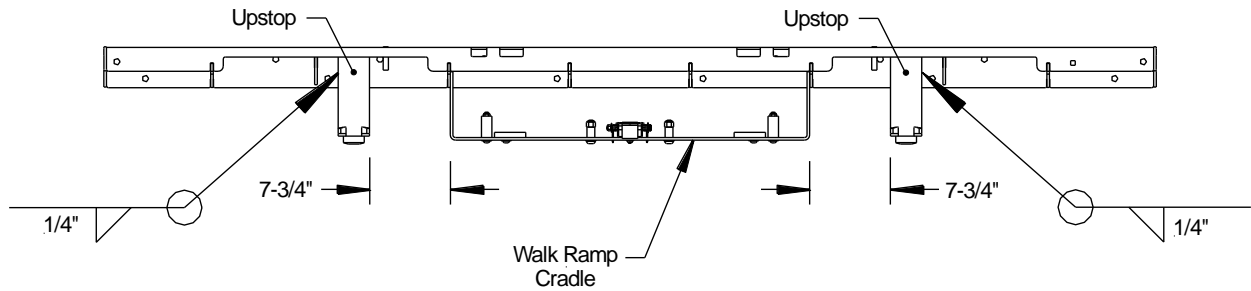

The upstop pad is adjustable by removing the hardware and positioning the pad in a configuration to make better contact with the edge of the platform 'shoes' (curb side and street side). Contact point between platform shoes and unstop pad should be centered as shown below.

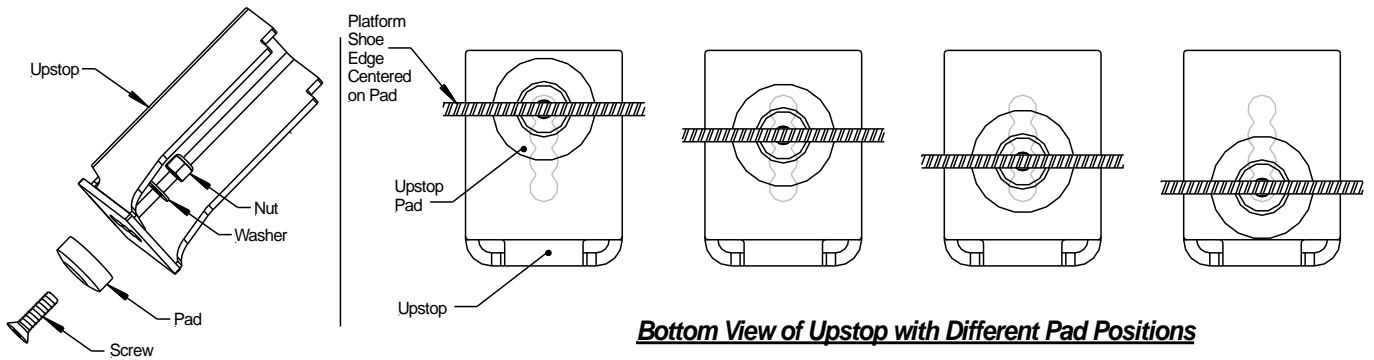

Bottom View of Upstop with Different Pad Positions

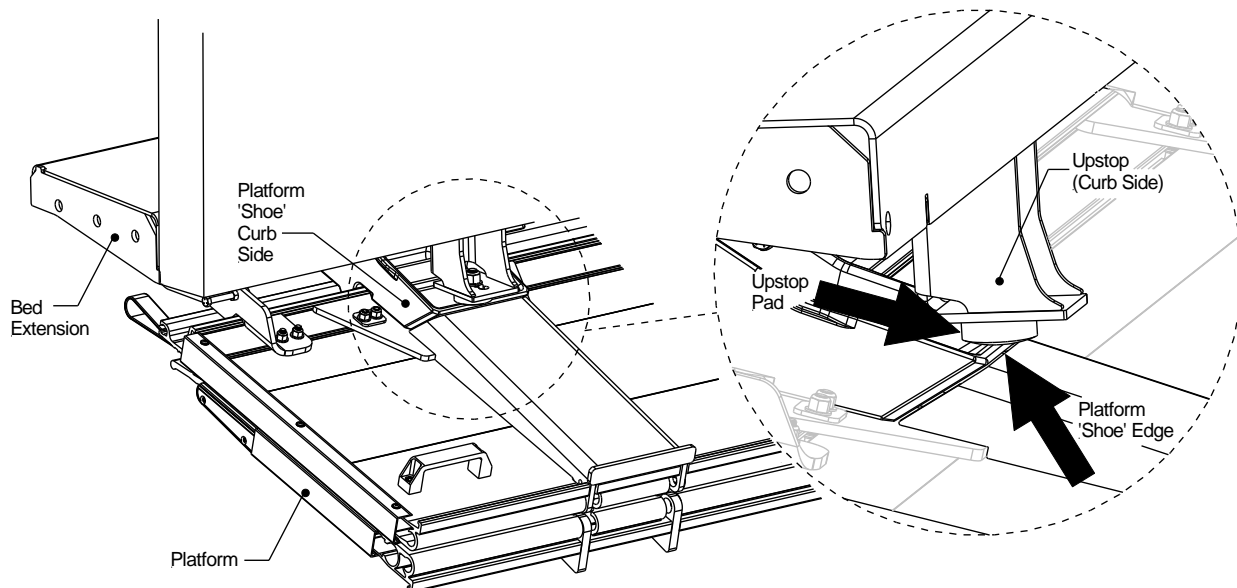

4. **Walk Ramp Extension:** Install the walk ramp extension onto the dock bumpers using three 1/2"-13x1.5" bolts, washers and nuts for each walk ramp extension. Next, install the rubber bumper onto the walk ramp extension. Install the walk ramp extension caps after all bolts have been tightened. *NOTE: UHMW bumpers will vary in size depending on specifications. The walk ramp extension accept 5", 16", and 24" UHMW bumpers. Shown below is the 24" bumper installed.*

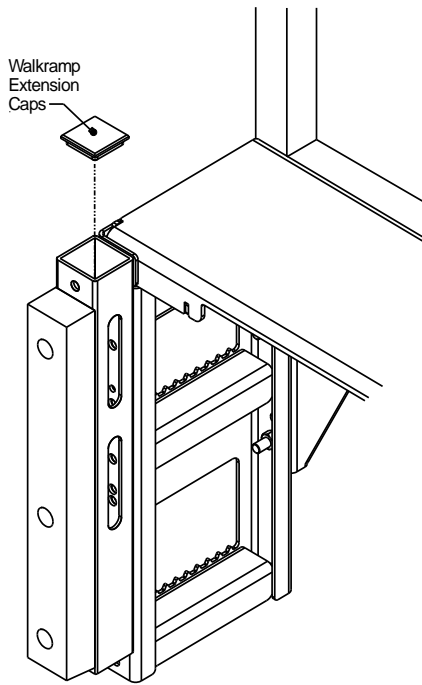
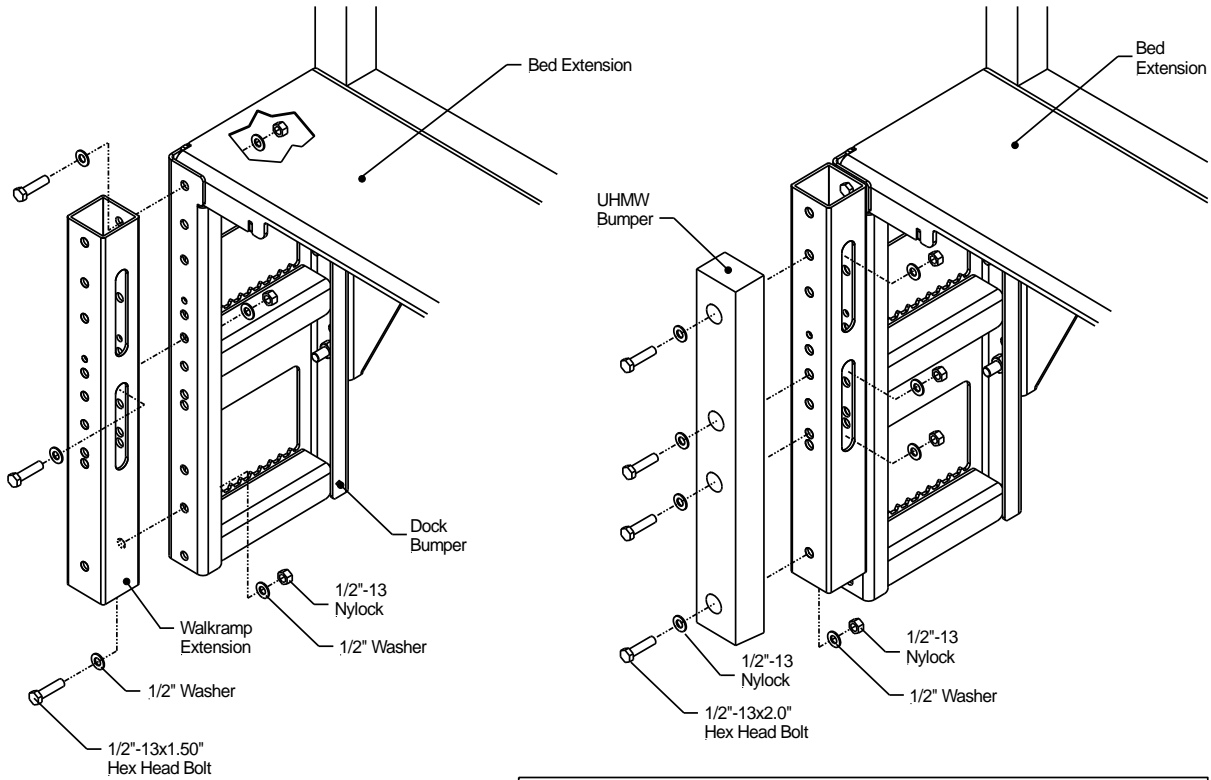

NOTE: The Walkramp Extensions are required to be installed. On vehicles where dock bumpers have not been installed, custom dock bumper structures will need to be installed to mount the Walk Ramp Extensions. INTERLIFT Liftgates does not supply material for these custom dock bumper structures.

13 Electrical Installation

⚠ WARNING

Any deviation from INTERLIFT Liftgates's recommended power setup **will void warranty and product liability** unless you have a written confirmation by INTERLIFT Liftgates that allows you to do specific changes.

NOTICE

- It is the liftgate installer or incomplete vehicle builder responsibility to be certain all chassis ground systems are adequate for the job. Liftgates with single motor can pull 250 amps at full load, and liftgates with dual motors will pull 500 amps at full load. These requirements include liftgate charging systems and OEM chassis battery grounding. Failure to adequately ground the whole system can lead to burned electrical harness, metal braided hoses, and other vehicle components.
- Never exceed rating of existing fuses located at the battery, control board and/or the pump and motor which may result in serious damage to the equipment.
- Never jump the 150 Amp circuit breaker at the batteries unless otherwise instructed by the INTERLIFT Liftgates technical support group.
- Assure all connections are tight and securely sealed.
- Heat shrink all cable connection.
- Never secure a cable in a way where it can make contact with other wiring, brake, fuel, or air lines etc. or get pinched against other objects.
- 2 gauge cable, minimum, is required throughout the motor circuit.
- When working on the electrical installation, remove any jewelry, tools, or components that are conductive to prevent any damage or injuries.
- Insure that all wiring is secured and away from heat sources, sharp corners/edges, and abrasion from moving components during the operation of the liftgate and vehicle.
- Pump and motor identification:

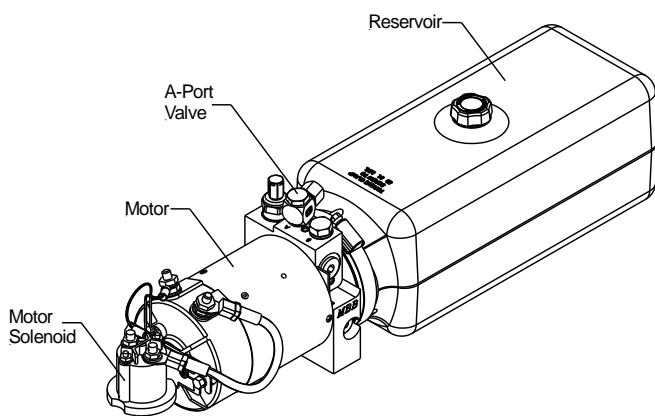

Gravity Down Pump and Motor

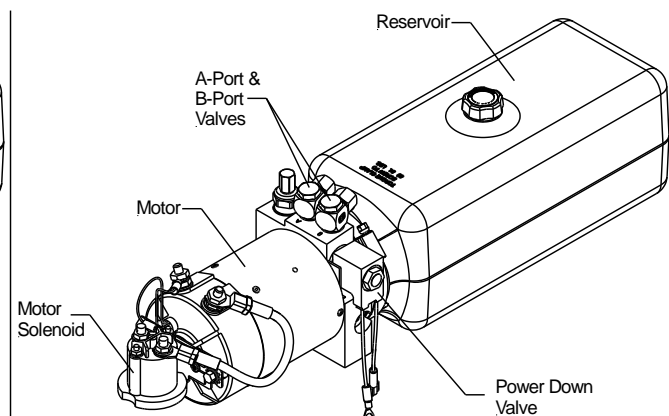

Power Down Pump and Motor

13.1 Electrical Wiring – Batteries – Truck/Trailer

*Resettable Circuit Breaker: 150 Amp Min. **Replace with same amperage breaker when necessary.**

Ground: For optimal grounding, ground all batteries and power units to the body side rails of the vehicle.

NOTICE: DO NOT attempt to jump in-line fuses with other objects other than the specified fuse.

Do not increase the amperage rating of fuse. Serious harm to the liftgate will result when standard practices are not followed.

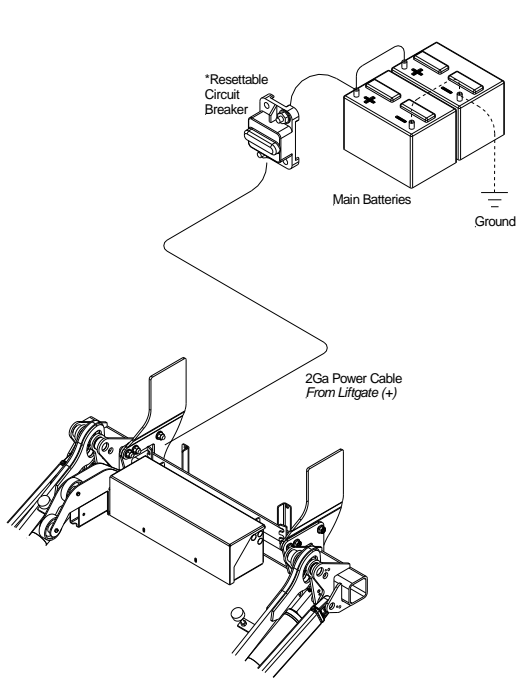

Wiring Diagram – Truck

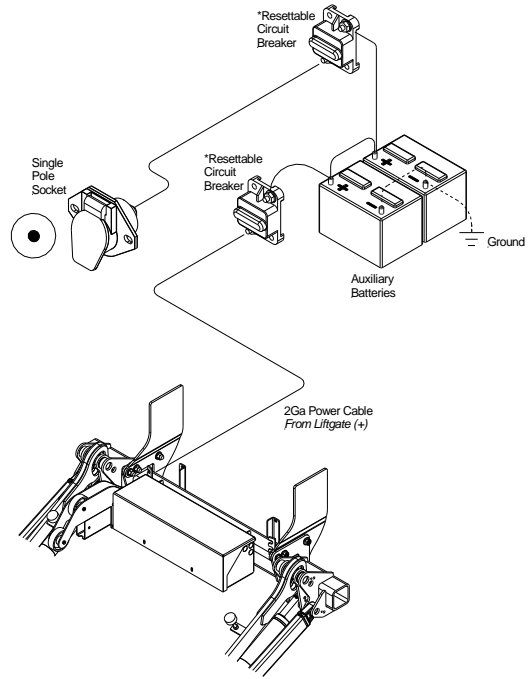

Wiring Diagram – Single Pole - Trailer

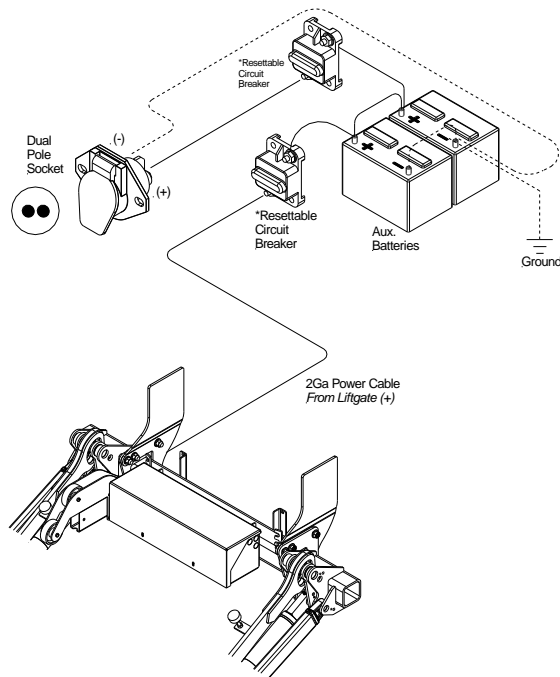

Wiring Diagram – Dual Pole – Trailer

13.2 Cable Routing

1. The use of wire loom is highly recommended to protect and facilitate cable routing. Wire loom not supplied.
2. Route all cables along the wooden spacer and through the outside of the U-bolts or on the inside part of the channel.
3. Secure the wire along the wooded spacer with insulated cable clamps.

⚠ WARNING Do not tie electrical cables along with hoses.

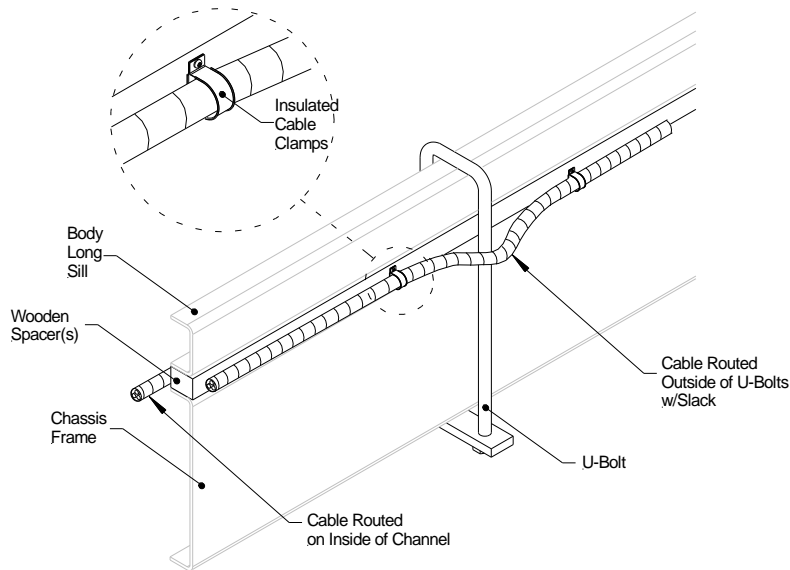

13.3 Connecting Power to Liftgate

1. Remove the cover from the Hydraulic Power Unit enclosure by removing the two wing nuts. Insert one end of the power cable through the indicated opening on the hydraulic power unit enclosure. Remove the nut from the solenoid post and attach the power cable to the post. Torque the nut to 3 ft./lbs. Route the other end of the power cable to the circuit breaker by the batteries.

NOTE: Do not disconnect any of the pre-installed wires on the solenoid or motor.

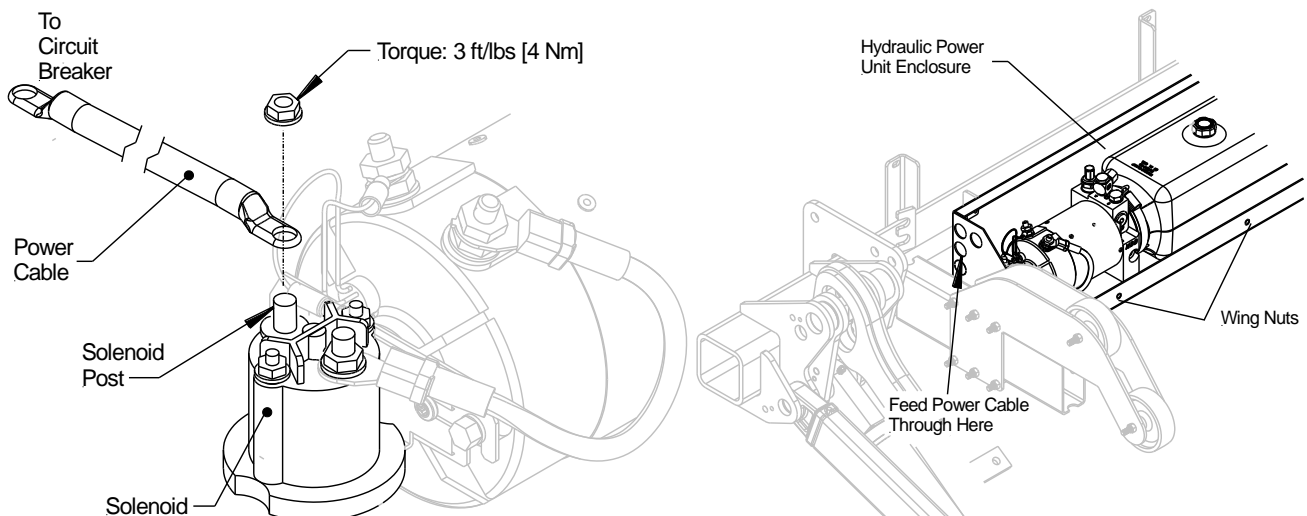

13.4 Wire Crimping

⚠ All grounding surfaces MUST be cleaned, prepped, and sealed per this manual. “Cut to size” cables MUST be properly crimped and sealed as factory supplied. All connections MUST be dressed with dielectric grease or equivalent sealer.

Battery Cable Crimping

1. Prepare the wire to be crimped. Straighten out the exposed copper wire and insert into the battery terminal.
2. Use a crimping tool designed for crimping battery terminals for best results. The use of other tools could possibly damage the battery terminal and make poor connections between the wire and terminals.
3. Slide the provided heat shrink over the battery terminal and cable to seal the connection.

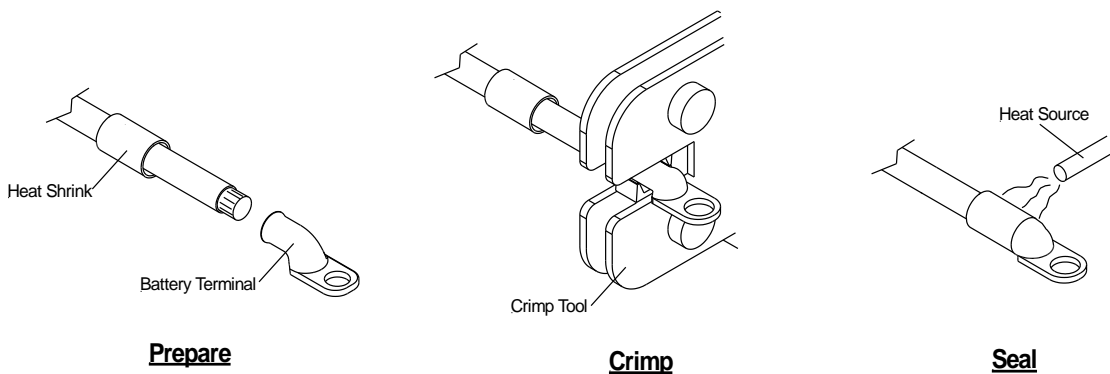

13.5 Circuit Breaker Installation

1. Battery Mount: Attach the bus bar to the circuit breaker on the BAT post. Mount the circuit breaker securely on the positive terminal post of battery, **Fig.40**.
2. Battery Box Mount: When mounting the circuit breaker in a battery box, connect a 2 gauge jumper from the BAT post on the circuit breaker to the positive post of the battery, **Fig.41**.
3. Connect the liftgates 2 gauge power cable to the AUX post on the circuit breaker.

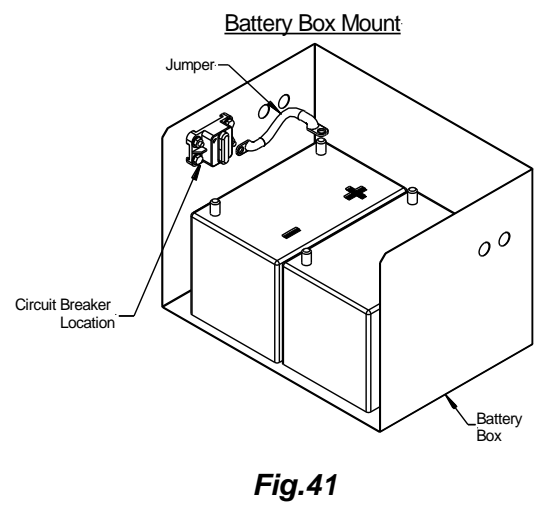
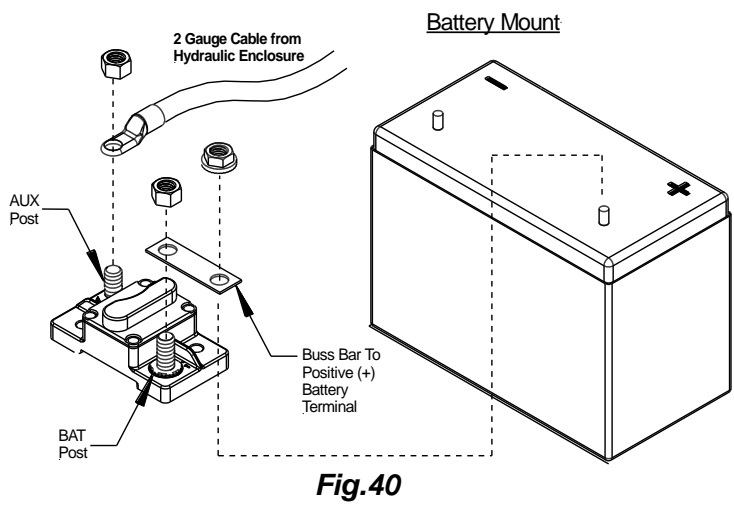

13.6 Toggle Switch Installation



The Toggle Switch is weatherproof from factory, do no substitute or tamper with the switch.

NOTICE

Determine location for fixed toggle switch on corner post in a way that the operator can view the platform and surrounding areas while operating the liftgate. Place toggle switch in a horizontal position

Steps:

Roll Up Door Vehicles

1. Mounting Hole Pattern: Locate area on rear curb side post of body where switch can be reached by the operator from the ground. Position the holes approximately 24" up from vehicles floor. Drill two 5/32" (.156") holes spaced at 1-3/4" vertically, and one 7/8" hole, centered to the two 5/32" holes, for the switch cable harness, **Fig.42.**
2. Wiring: Route cable harness through rear post and down to the hydraulic power unit. Heat shrink or protect all connections. Use cable clamps to keep the cable clear of all moving parts. Reference the wiring diagrams in Sections 13.9-13.10
3. Operation: Verify all operations are functional as intended. Secure the switch to the corner post with the two #10-24 x 1" self-tapping screws.

IMPORTANT: Screws must be hand tighten, do not use power tools to tighten screws.

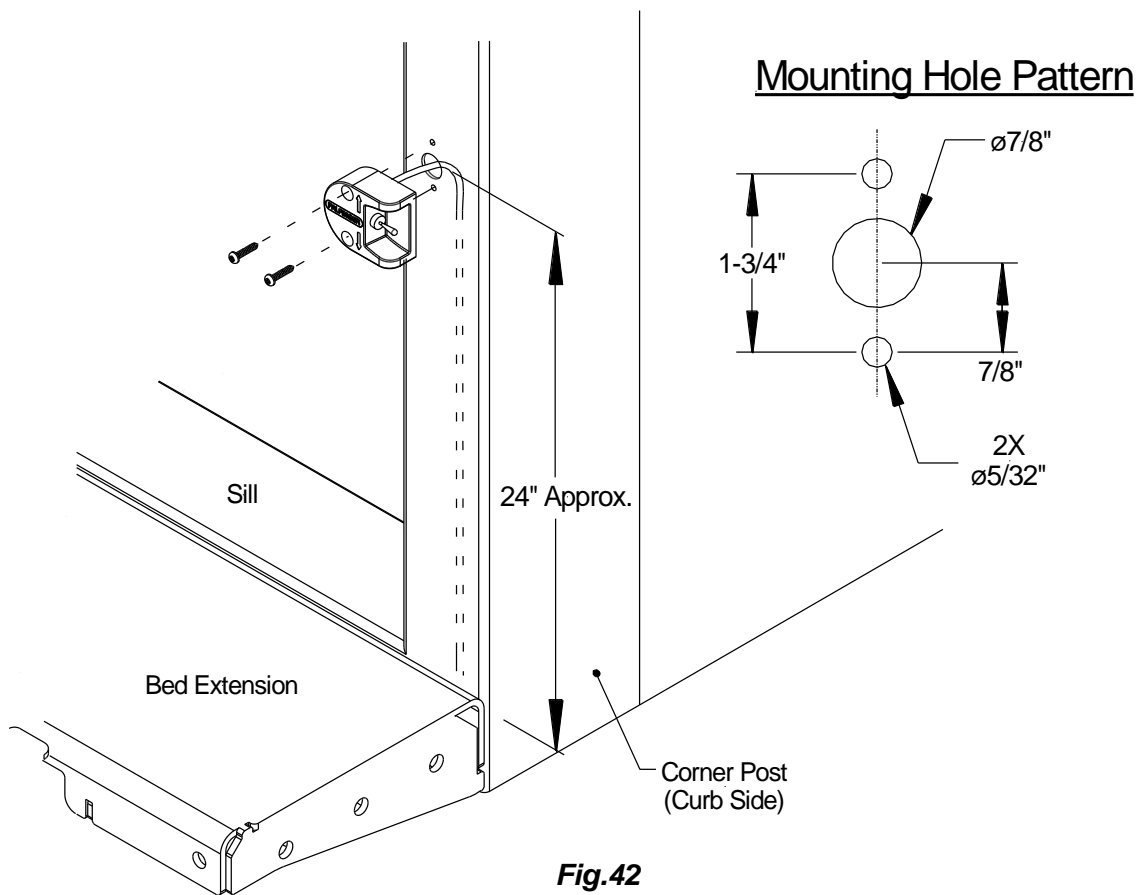
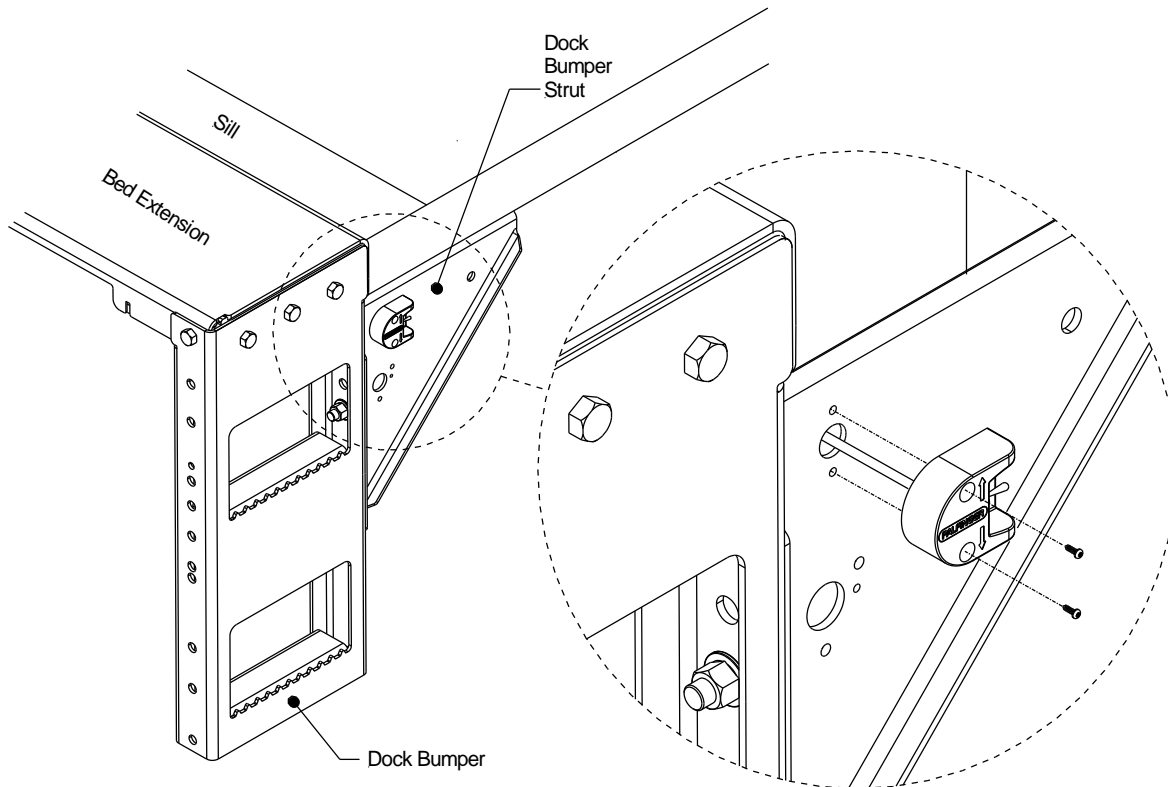

Fig.42

Stake Bed Vehicles

1. **Mount Switch:** Mount toggle switch to dock bumper strut using two #10x1-1/2" self-tapping screws.



2. **Route Wire:** Route the toggle switch harness along the vehicle body down to the pump and motor. To prevent damage to the harness, properly secure the harness and keep cleared from any moving liftgate parts.
3. **Connect wires:** Reference Sections 13.9-13.10 for wiring according to your liftgates specifications.
4. **Check Switch Operation:** Verify that the up and down functions on the toggle switch operate as intended.
5. **Seal Connetions:** Heat shrink and seal all connections, if applicable.

13.7 Liftgate Shut-Off Switch

NOTICE

Liftgate Cab ON/OFF Switch **MUST** be installed and in clear view of driver.

Steps:

1. Mounting Switch:

Truck Application: Install the liftgates shut off switch on the vehicles dashboard in clear view of the driver and within reach from the ground, **Fig.43.**

Trailer Application: Install the shutoff switch on the dock bumper strut, if applicable, or use the faceplate to install the switch on the vehicles body as shown (faceplate requires a 2" hole to be drilled on vehicle body for installation), **Fig.44.**

Decal: Apply the accompanying decal in the surrounding area of the switch.

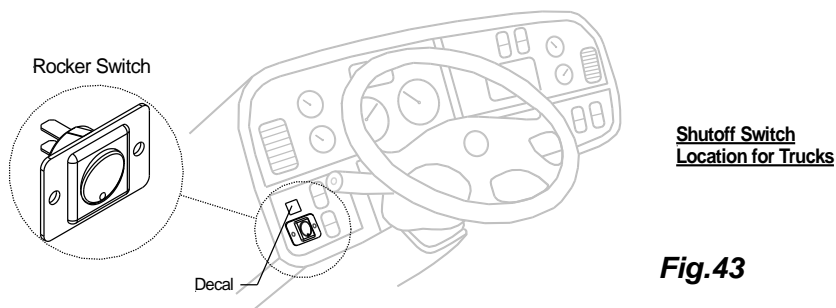

Fig.43

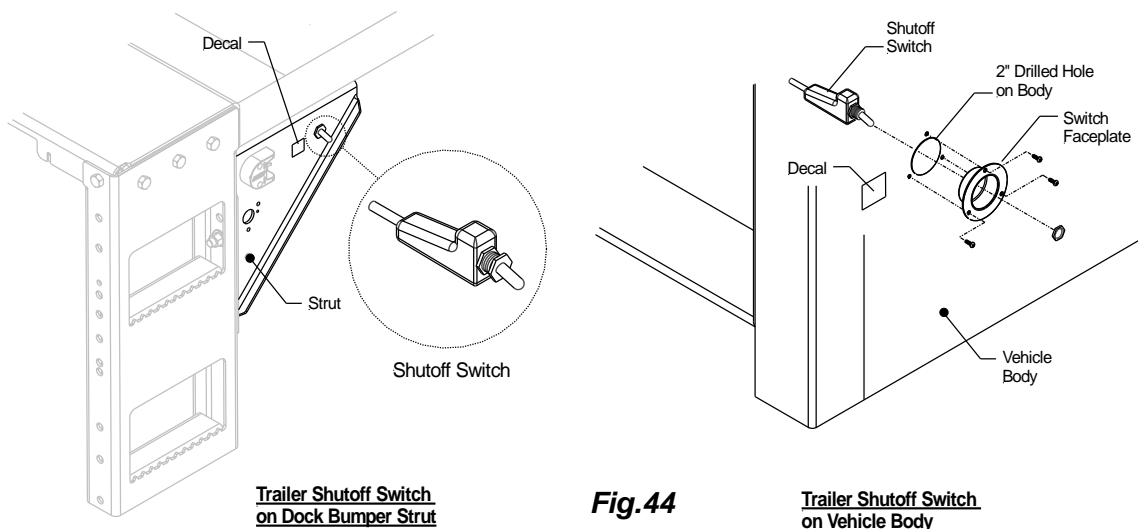

Fig.44

2. Route Wire: Route and secure the control wire cable every 12 inches against the frame with frame clamps or equivalent along the frame to pump & motor box.
3. Check Wire Clearance: Verify wire is clear of all moving parts and securely tied up.
4. Cover Connections: Heat shrink or protect all connections.
5. Wiring: Reference Section 13.9-13.10 for wiring according to the liftgates specification's.



Rocker switch shall not be installed anywhere outside the truck cab.



Inspect and test all electrical connections, wiring and the different functions to make sure that the electrical installation is complete.

Routing Switch Harnesses to Pump and Motor

1. Route each harness to the hydraulic power unit enclosure and secure harnesses with the supplied cable ties. Keep harnesses away from sharp corners and moving parts.
2. Feed the harnesses through the cable entry slots on the enclosure as shown, **Fig.45**.
3. Wire switches accordingly per Wiring Diagrams in Sections 13.9-13.10.

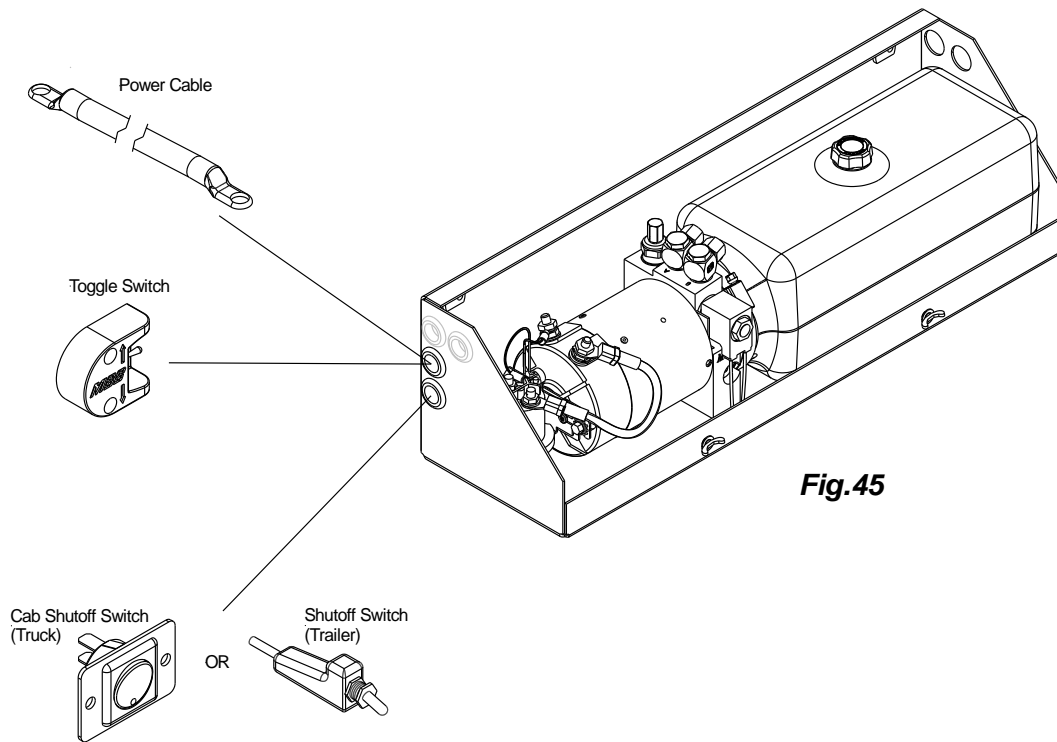

13.8 2-Button Hand Held Remote Control (Optional)

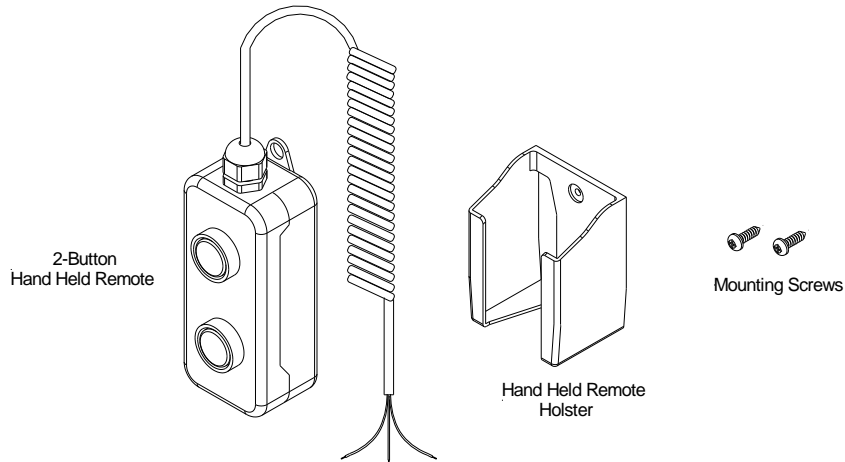

1. Mount the holster approximately 40"- 48" from the floor, or determine the best location as preferred by end user, **Fig.46**.
2. Route the cable from the liftgate up through the inside corner post or between the wall extrusions of the truck. Use the wire clamp to secure the incoming cable, **Fig.47**.
3. Splice the cables from the liftgate to the hand held remote with butt connectors and seal each connection with heat shrink.

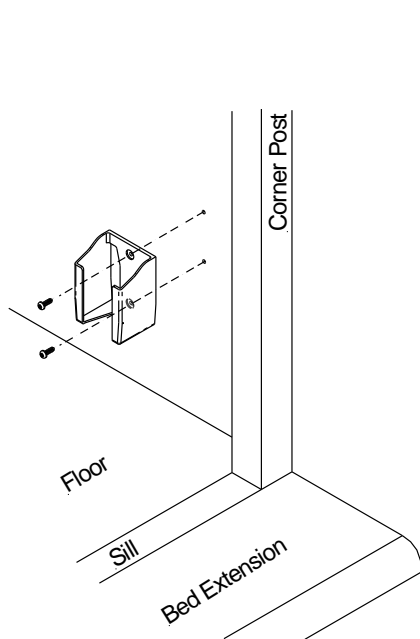

Fig.46

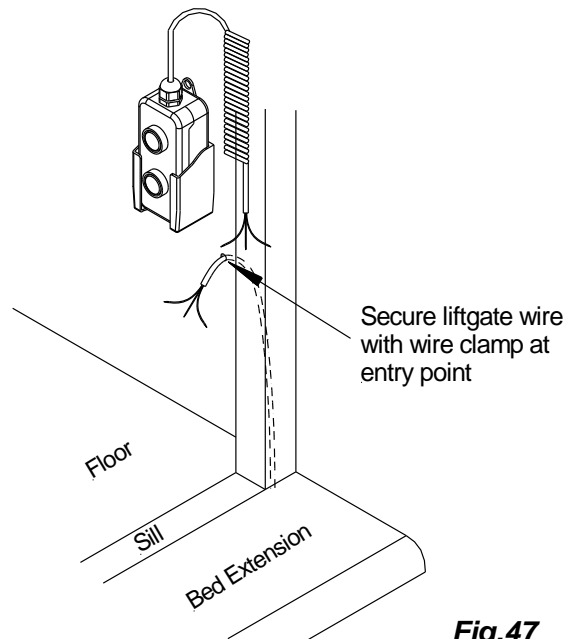
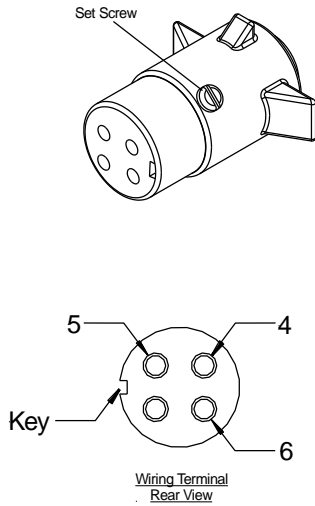

Fig.47

Wiring Table

Function	To	Wires From Gate/Number
Up	Solenoid	5 / Red
Down	Release Valve	6 / Yellow
12V (Hot)	ON/OFF Switch	4 / Green

4. Use a plug and socket when the vehicle is a refrigerated body. Remove the set screw to access the wire terminals. **Never store remote inside refrigerated vehicles, control will be damaged.**



Plug
Plug to Control Wiring Table

Function	Plug	Remote
Up	5	5.2 / Red
Down	6	6.2 / Yellow
12V (Hot)	4	4.3 / Green

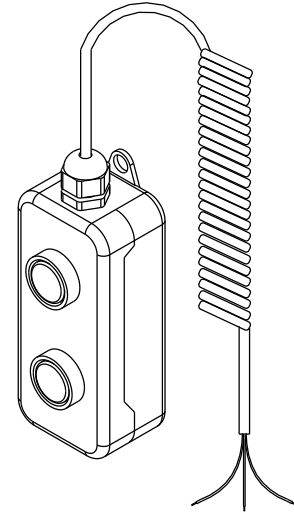

Hand Held Remote

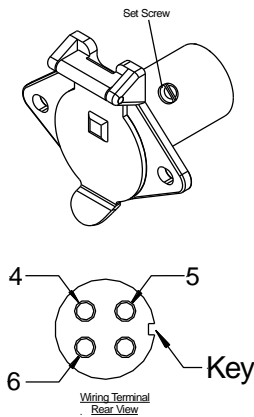

Socket
Socket to Pump/Motor

Function	Socket	Pump Motor
Up	5	Solenoid
Down	6	Release Valve
12V (Hot)	4	On/Off Switch

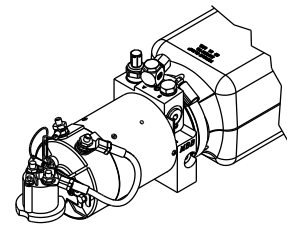

Hydraulic Power Unit

5. Reference Sections 13.9-13.10 for wiring diagram.

13.9 Electrical Schematic (Gravity Down)

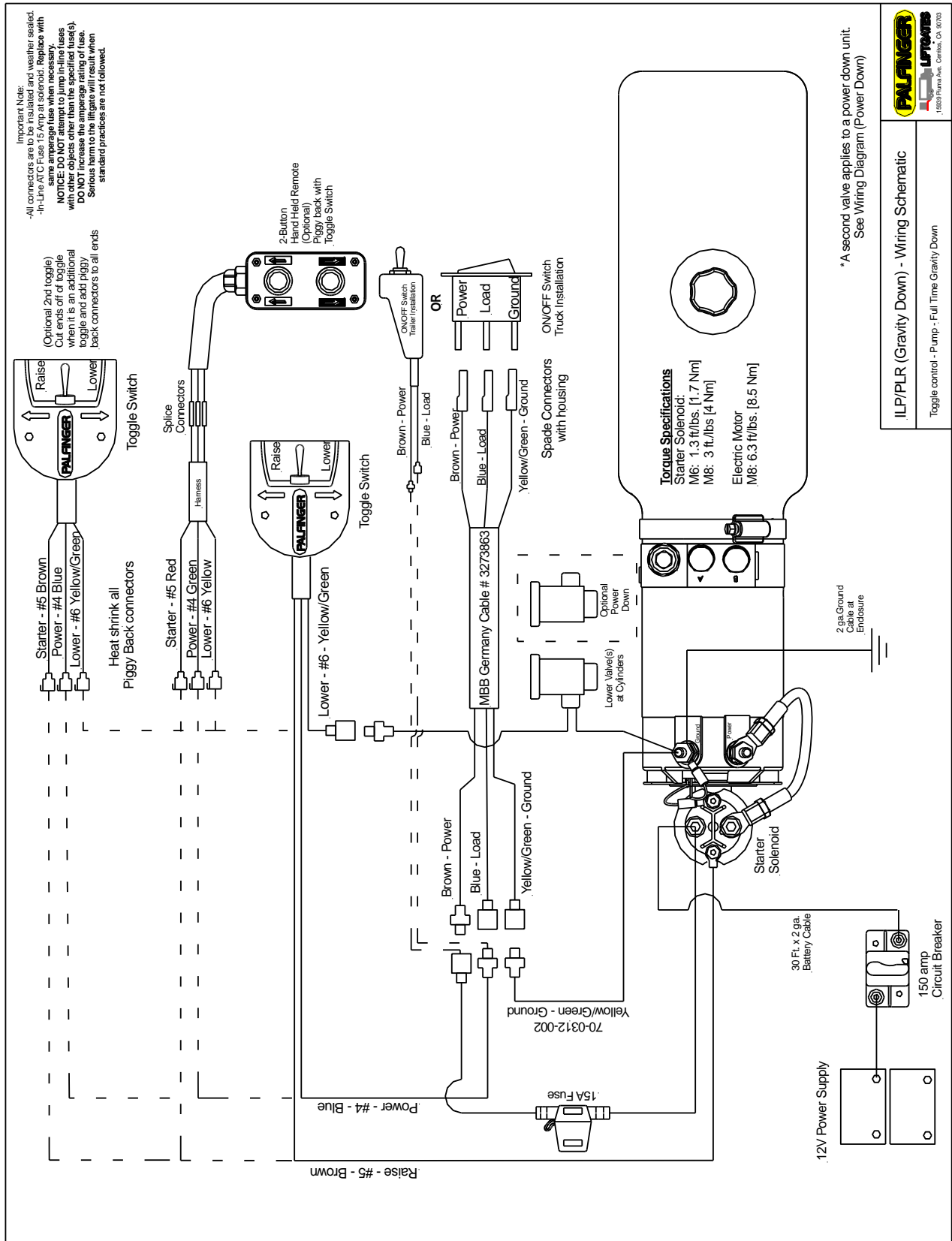

*A second valve applies to a power down unit. See Wiring Diagram (Power Down)

ILP/PLR (Gravity Down) - Wiring Schematic
 Toggle control - Pump - Full Time Gravity Down

 15883 Palm Ave. Corona, CA 92703

13.10 Electrical Schematic (Power Down)

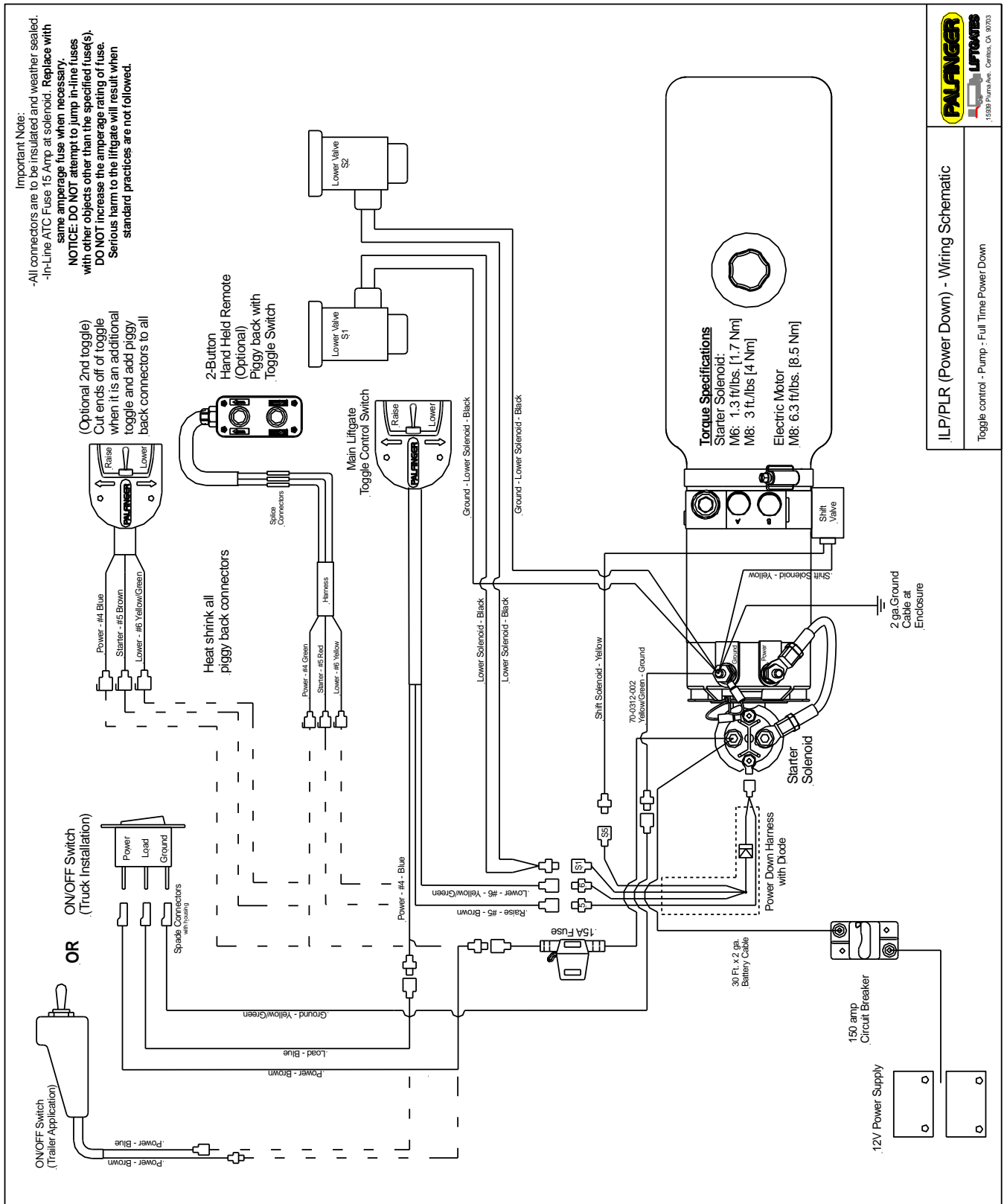

FALANGER
LIFTGATES
 15389 Purna Ave. - Corcoran, CA 90703

ILP/PLR (Power Down) - Wiring Schematic

Toggle control - Pump - Full Time Power Down

14 Hydraulic Schematic (Gravity Down)

NOTICE

- Insure that all hydraulic hoses are secured and away from heat sources, sharp corners/edges, and abrasion from moving components during the operation of the liftgate and vehicle.

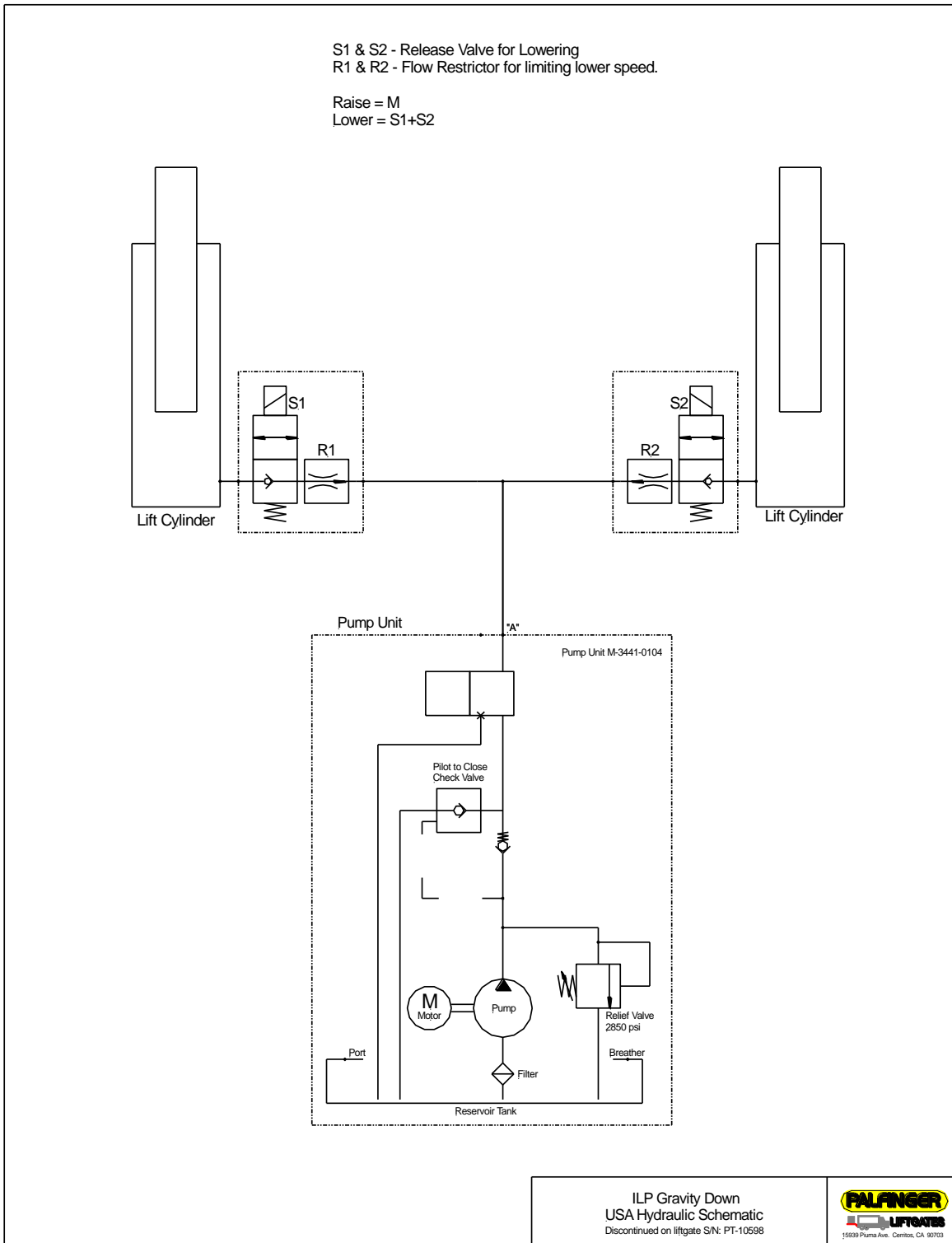

ILP Gravity Down
 USA Hydraulic Schematic
 Discontinued on liftgate S/N: PT-10598



14.1 Hydraulic Schematic (Power Down)

S1 & S2 - Release Valve for Lowering
 R1 & R2 - Flow Restrictor for limiting lower speed.
 S5 - Shift Valve is activated upon LOWER function only.
 Pilot to close check valve is NOT used on Power Down.

Raise = M
 Power Down = M + S1&2 + S5

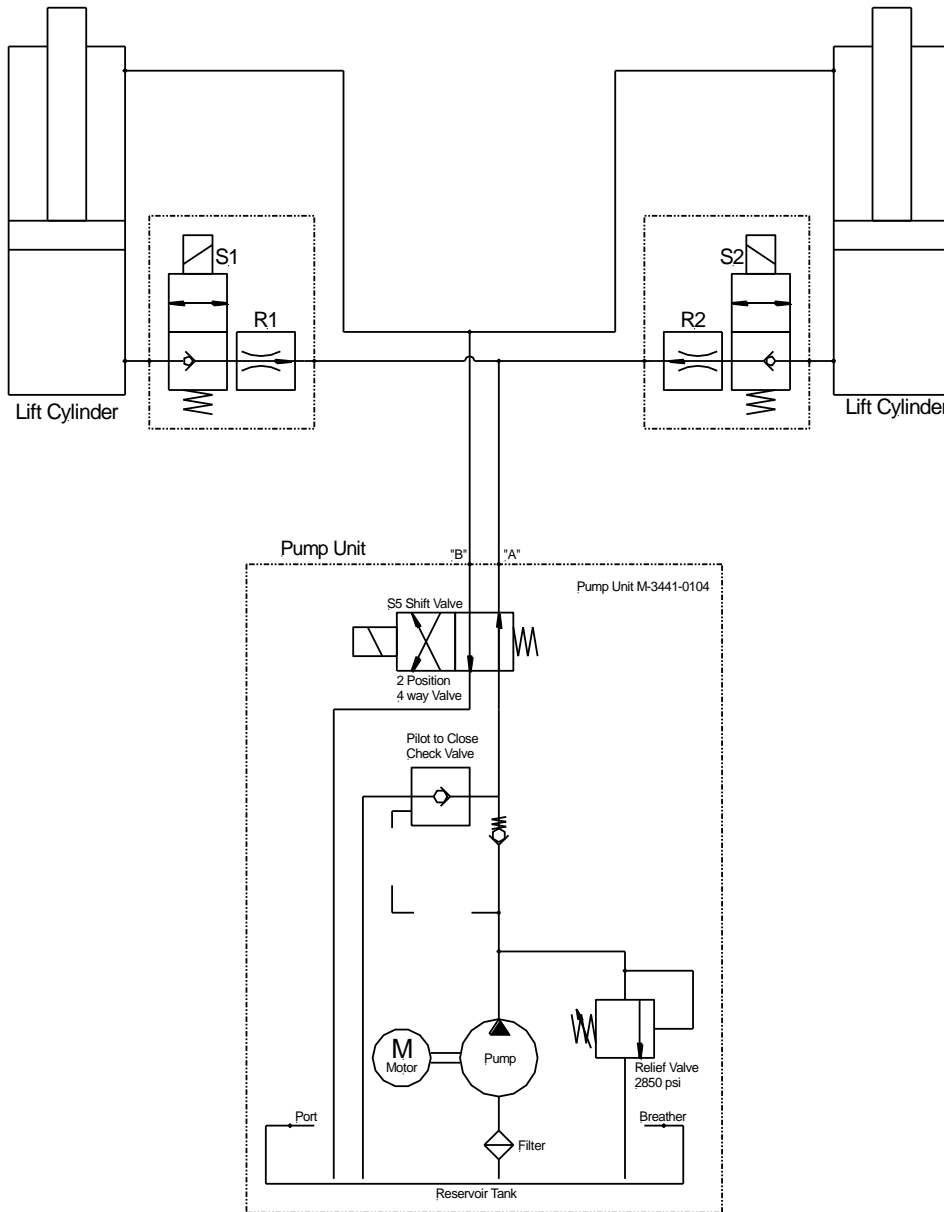

MBB Toggle Control; Full time Power Down ONLY

ILP Power Down
 USA Hydraulic Schematic
 Discontinued on liftgate S/N: PT-10598



14.2 Hydraulic Fluid

All ILP liftgates are equipped with Hydrex MV Arctic 15 hydraulic fluid from factory.

Hydraulic Fluid Installed From Factory	
Property	HYDREX MV ARCTIC 15
<i>Start Up Temperature</i>	<50°C / -58°F
<i>Operating Temperature</i>	-45°C to +23°C / -49°F to 73°F
<i>Pour Point</i>	-57°C / -71°F
<i>Flash Point</i>	128°C / 262°F
<i>Density 15°C (59°F). kg/L</i>	0.834
<i>Viscosity:</i> <i>cSt @ 40°C/SUV @ 100°F</i> <i>cSt @ 100°C/SUV @ 210°F</i> <i>cP @ -50°C (-58°F)</i>	13.0 / 69.7 4.95 / 42.5 1,310

When changing or adding fluids, it is highly recommended to use Hydrex MV Arctic 15 fluid, however, the alternatives fluid brands listed below can be used.

Alternative Fluids	
Temperature Range	Fluid Brand
30° to 150° F	EXXON UNIVIS J26
	MOBIL DTE 13M
	CHEVRON AW MV32
	ROSEMEAD MV 150 (32)
-50° to 150° F	MOBILE DTE 11
	SHELL AERO FLUID 4/41
	SHELL TELLUS 15
Extreme Cold Temperature	MIL H5606 (Military Spec.)

15 Decal Placement and Inspection



For operator's safety, all decals appearing in "Decal Kit" must be placed visibly on the control side of liftgate to be read by operator. This is typically a combination of decals on the liftgate and truck/trailer body. Make sure to place the maximum capacity decal (D) on driver and curb side of the vehicle.

Important: Never remove or paint over any decal. If any decals below require replacement contact INTERLIFT Liftgates for replacements.

Decal Kit			
Decal	Qty.	Part No.	Description
A	1	ATG-URGWA	Urgent Warning: Elevating gate instructions
B	1	ATG-ILR-ILFS	Operating Instructions
C	1	ATG-BKR	Circuit Breaker Reset (must be located at the circuit breaker)
D	2	ATG-XXXX	Capacity (check the serial number plate to find out the gates specific capacity).
E	1	ATG-RESET	Circuit Breaker Protection
F	2	ATG-WLH	Warning: liftgate can crush
G	2	ATG-PLAT	Warning: Always stand clear of platform area
H	1	ATG-CAB	Liftgate Shut-Off (Place Decal next to the On-Off Switch in the Cab)
I	1	ATG-UD	Toggle Switch Decal (located on post for Trucks) Or (located on strut brace for flatbeds)
J	1	ATG-WNG	Warning: Use handle to open (must be located underneath handle (main section))

NOTICE

It is the installer's responsibility to determine that the vehicle meets DOT and federal lighting regulations. Keep in mind that there are different requirements depending on the classification of the vehicle. This document is not intended to replace published agency regulations, and it is strongly recommended that the installer references the Code of Federal Regulations (CFR) which can be viewed at <http://www.ecfr.gov>

Decal - A

URGENT WARNING

BEFORE OPERATING LIFT, BE SURE YOU UNDERSTAND:

- Improper operation of this lift gate can result in serious personal injury. Do not operate unless you have been properly instructed, have read, and are familiar with, the operating instructions. If you do not have a copy of the instructions please obtain them from your employer, distributor or lesser, as appropriate, before you attempt to operate the lift gate.
- Be certain the vehicle is properly and securely braked before using the liftgate.
- Always inspect this lift gate for maintenance or damage before using it. If there are signs of improper maintenance, damage to vital part, or a slippery platform surface, do not use the lift gate. Do not attempt your own repairs, unless you are specifically trained.
- Do not overload. See the Mfg. Literature and/or Rating Label on the unit for the rated load. Remember that this limit applies to both raising and lowering operations.
- Each load should be placed in a stable position as near as possible to the center of the platform.
- Never allow yourself, a helper, or a bystander to stand in a position where an unstable load might fall on them. Do not allow any part of your or your helper's body to be placed under, through, or around any portion of the moving lift gate, or in a position that would trap them between any parts when the lift gate is opened.
- This lift gate is intended for loading and unloading of cargo only. Do not use this lift gate for anything but it's intended use. The lift gate is not equipped with a back up system to prevent falling in the event of a failure.

ATG-0099A13

Decal - B

NOTICE

To operate and use lift gate:
 Follow operation details from step 1 to 4:
 1. To check and put away lift gate:
 - MBB (Master Brake Bar) DOWN
 - All 4 legs fully extended
 - Load on platform
 - Release the MBB (Master Brake Bar)
 2. To check and put away lift gate:
 - MBB (Master Brake Bar) DOWN
 - All 4 legs fully retracted
 - Load off platform
 3. To check and put away lift gate:
 - MBB (Master Brake Bar) DOWN
 - All 4 legs fully retracted
 - Load off platform
 4. To check and put away lift gate:
 - MBB (Master Brake Bar) DOWN
 - All 4 legs fully retracted
 - Load off platform

ATG-0099A13

Decal - C

NOTICE

ELECTRICAL SYSTEM PROTECTED BY RESETTABLE CIRCUIT BREAKER

TO RESET - PUSH RESET TAB IN

ATG-BKR

CAUTION

Maximum Load Capacity

XXXX pounds.

Center load on platform to avoid personal or property damage.

ATG-1000

NOTICE

ELECTRICAL SYSTEM IS PROTECTED BY A RESETTABLE CIRCUIT BREAKER. SEE OWNER'S MANUAL AND DECAL LOCATED AT THE BATTERY.

ATG-RESET

WARNING

LIFTGATE HAZARDS CAN RESULT IN CRUSHING OR FALLING

KEEP HANDS AND FEET CLEAR OF PINCH POINTS

IF RIDING LIFTGATE, MAKE SURE LOAD IS STABLE AND FOOTING IS SOLID

READ AND UNDERSTAND ALL INSTRUCTIONS AND WARNINGS BEFORE USE.

Decal - E

WARNING

ALWAYS STAND CLEAR OF PLATFORM AREA

ATG-PL1

Decal - F

NOTICE

LIFT GATE SHUT-OFF

TO BE TURNED OFF WHEN LIFT IS NOT IN USE

ATG-LSB

NOTICE

UP

DOWN

ATG-UD

Decal - D

WARNING

USE HANDLE TO OPEN

ALWAYS STAND CLEAR OF PLATFORM AREA WHEN OPERATING THIS GATE

ATG-1000

Decal - G

Decal - H

Decal - I

Decal - J

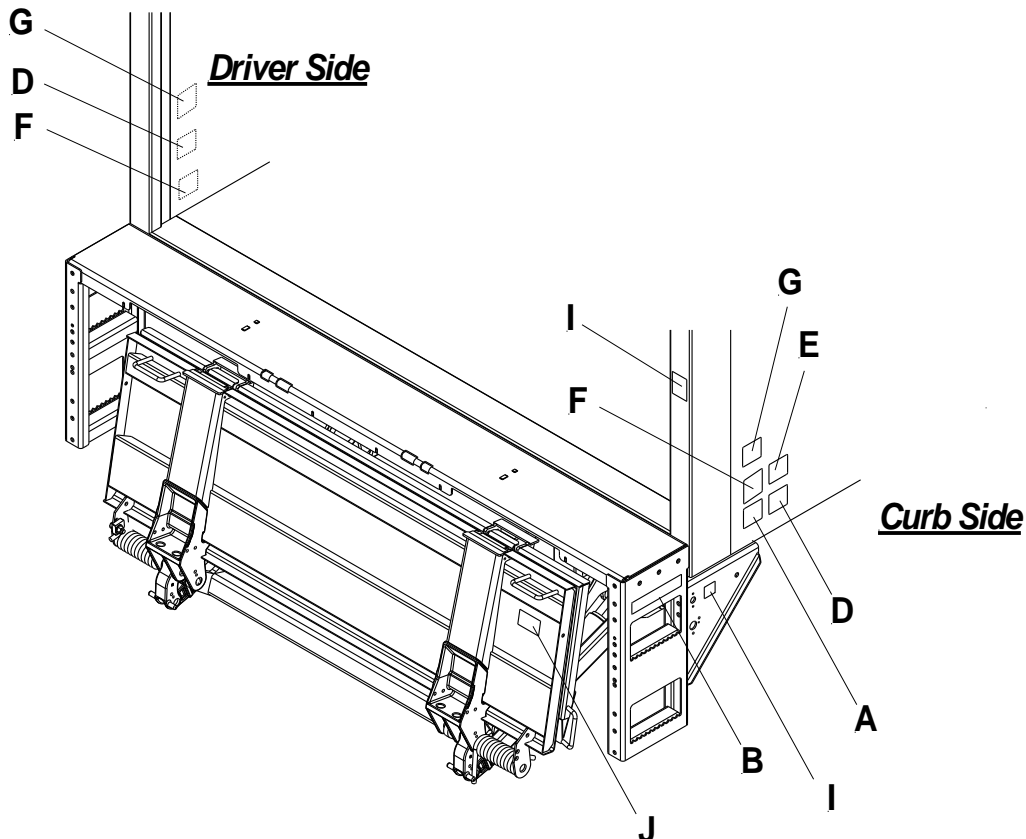

16 Lubrication

1. Lower the platform to the ground.
2. Remove red protector caps from each component. Lubricate, grease, and oil per diagram below.
3. Cycle platform up and down several times. Lubricate and grease all points again.
4. Wipe any excess grease and replace all red protector caps on zerks.

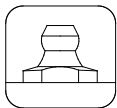
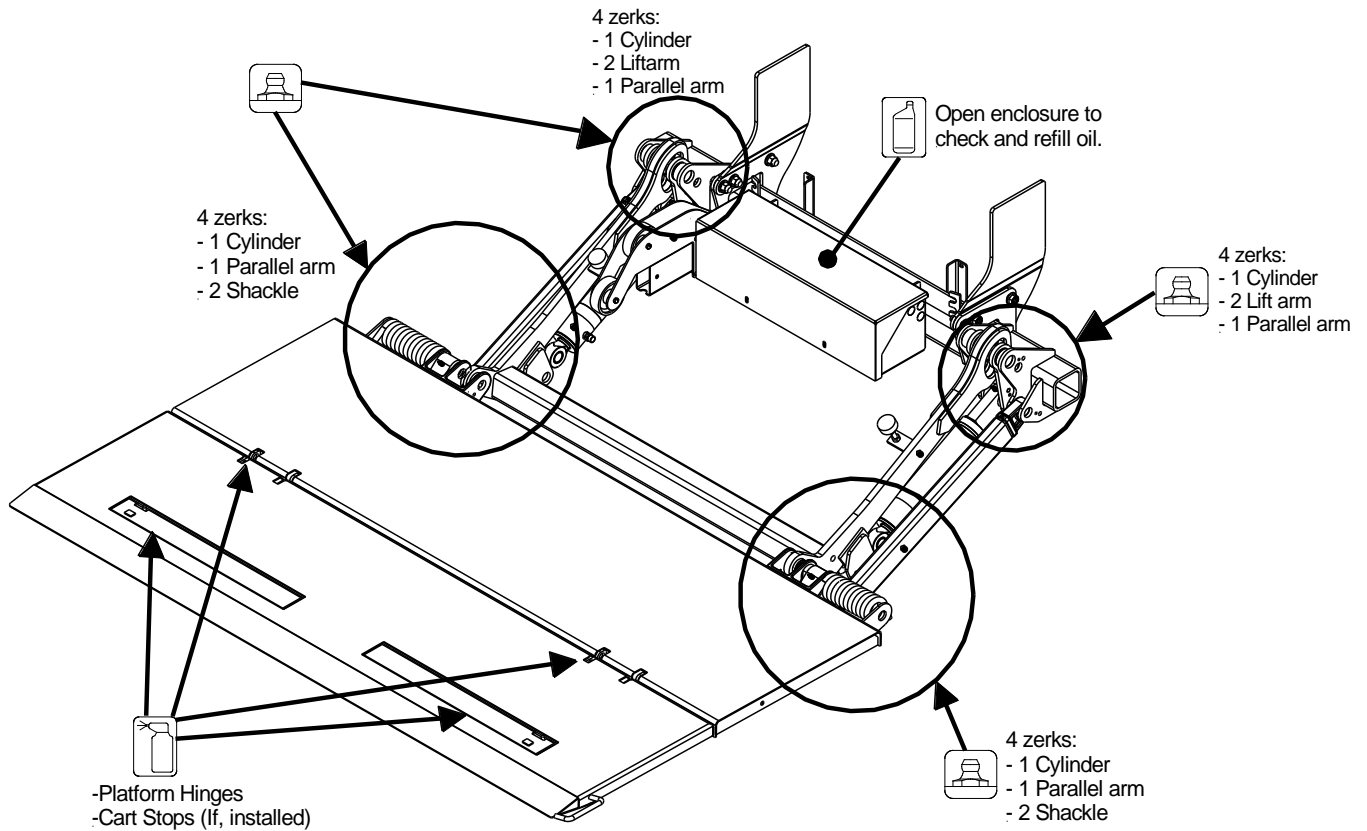

Grease: Location of Grease Zerks (7 on each side, 14 total).

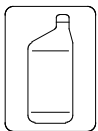

Oil: Oil level in the power pack tank (see marking inside of power pack reservoir).

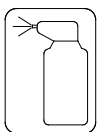

Lubricate: Platform hinges, Slide Rails and optional Cart Stops.

17 Final Inspection Check List



Liftgate failure or malfunction could result in property damage, personal injury or death if you fail to check each of the following items listed. DO NOT USE the liftgate if any of the following points are NOT verified and checked.

Installation is NOT complete and all WARRANTIES are VOID if you have not checked and verified all items listed on this inspection sheet. Inspection sheet is to be filled out at the facility where liftgate was installed and **MUST** be sent to INTERLIFT Liftgates for warranty activation.

Structural Inspection

- All welds are 100% complete per this manual.
- All nuts, bolts, mounting hardware, pins, chain anchors are tight.
- All mounting dimensions are correct and liftgate is square and parallel per this manual.

Hydraulic Inspection

- Pump reservoir is filled to 1" from top of reservoir when cylinders are completely compressed (platform is resting on the ground).
- Hydraulic components and connections do not leak.
(Should be checked after unit is hydraulically locked for five (5) minutes.)
- All hydraulic lines are secured with cable ties, hoses clamps, or other fasteners. No hoses or components rub on the frame, platform, or any other components while unit is in operation or in storage. No hoses are kinked or bent.

Electrical Inspection

- Battery cable(s) attached and clamped tight and dielectric grease is used to seal all connections.
- All electrical lines are secured with cable ties, hoses clamps, or other fasteners and are properly protected and away from sharp edges and moving parts.
- Circuit Breakers installed and wired per instructions.
- Measure battery voltages: Flooded Batteries = 12.6V; AGM Batteries = 12.8V
- Lights wired properly and operate per DOT, State, and Federal requirements.

Operational Inspection

- All decals are in place and legible per instructions.
- All pivot points are lubricated per instructions, and serk fittings have been capped.
- Up stops are in place. Wheel is set for proper opening when lowering.
- Coil springs have been adjusted at the platform for proper folding and unfolding tension.
- Snubber pads are adjusted tight against platform.
- Bolts or welds are removed from both swing arm fixtures (Section 12.3).
- Platform travels up and down smoothly and freely, without any hesitation, interference, or unusual noises.
- Platform is flush with the bed extension, tip is pitched 2" above rear bed extension when raised completely.
- Platform rests on the ground evenly when lowered completely.
- Platform raises and lowers properly and at correct speed. (2 to 4 inches per second)
- Gate is painted, body is clean around gate. Chrome cylinder shafts are not painted. Rubber & plastic caps are in place.
- The liftgate serial number and model number are documented on the inside of the front cover of the Owners Manual (pg. 4), as well as the installation manual in the space provided (pg.4).
- Owners Manual is in the vehicle's glove box.
- Supervisor has demonstrated the instructions in the Owners Manual to the customer/driver upon delivery.

Inspection Information (Please Print):

Name: _____ Signature: _____

Completed by: _____

Title: _____ Date: _____

Liftgate Model: _____ Liftgate Serial Number: _____

