

INTERLIFT

BY PALFINGER

OWNER'S MANUAL

ILFP 30, 3000 lbs. Capacity

ILFP 40, 4000 lbs. Capacity

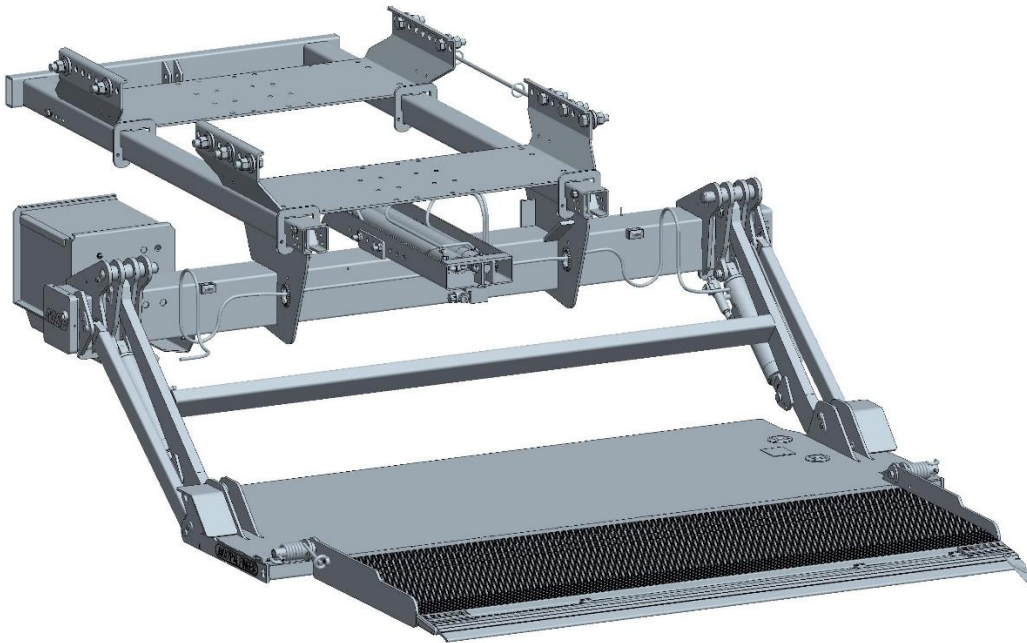

ILFP 30/40 Owner's Manual
Document Part Number: 90-1213-100
ECN-M1723, Rev. 1.6, 01-23-24
Copyright © 2023 Palfinger Interlift, LLC.
All rights reserved.

Information in this document is subject to change without notice.
Visit www.palfinger.com for up to date information and notifications.

If you received this product with damaged or missing parts,
contact INTERLIFT Liftgates at (888)-774-5844

Parts Order/Inquiries
liftgateparts@palfinger.com

Technical Support
technicalapplications@palfinger.com



BY **PALFINGER**

15939 Piuma Ave.
Cerritos, CA 90703
Tel (888) 774-5844
Fax (562) 924-8318



BY **PALFINGER**

572 Whitehead Road.
Trenton, NJ 08619
Tel (609) 587-4200
Fax (609) 587-4201

Table of Content

1. Manual Updates 6

2. Important Notes 7

 2.1 Attention 7

 2.2 Important Notes 7

 2.3 General Information 8

3. Safety Information 10

4. Basic Parts in Detail 12

 4.1 General View of Liftgate 12

 4.2 Circuit Board Connector Cables 13

 4.3 Control Box 14

 4.4 Flush mounted control (optional) 14

5. Maximum Load and Placing of Load on Platform 15

6. Operation of Liftgate 16

 6.1 Operating the ILFP with Control Box 16

 6.2 Operating the ILFP with the 3-Button flush mounted control 17

 6.3 Operating the ILFP with the 3-Button flush mounted control (Easy move model) 18

4. Operate the liftgate 18

 6.4 Operation by Hand Held Remote Control 19

 6.5 Operation by Foot Control 19

7. Preventive Maintenance and Quick Check 20

 7.1 Maintenance and Care 20

 7.2 Trailer to Tractor Connection Test 21

 7.3 Lubrication 22

 7.3.1 Lubrication Plan 22

 7.3.2 Checking and Changing the Oil 24

 7.3.3 Recommended Hydraulic Fluids 24

 7.4 Decal Placement and Inspection 25

 7.5 Quick Check List 27

8. Troubleshooting 28

 8.1 Basic Function Check 29

 8.1.1 LIFTGATE is completely DEAD (No Clicking or Movement at all) 29

 8.1.2 ON-OFF switch on, but all functions are dead 30

 8.2 Electrical and Hydraulic Schematic 31

 8.2.1 Main Wiring Diagram 31

 8.2.2 Electrical Schematics 32

8.2.2.1	Control board wiring and connector setup.....	32
8.2.2.2	Control board plug setup.....	33
8.2.2.3	Control board wiring and connector setup (Easy move model)	34
8.2.2.4	Control board plug setup (Easy move model)	35
8.2.3	Hydraulic Schematic.....	36
8.3	Functional Description of Hydraulics when Operating	37
8.3.1	Slide Out Function.....	37
8.3.2	Lower Down	37
8.3.3	Lift Up Function	37
8.3.4	Slide In Function.....	37
8.4	ILFP Push-Pull Valving	38
9.	Needed Information for Ordering Spare Parts and Repairs.....	39
9.1	Ordering Spare Parts	39
9.2	Repairs	39
10.	Warranty.....	40
11.	Contact Address.....	41

Table of Figures

Figure 1: ILFP Slide lift	12
Figure 2: Center Point of Load	15
Figure 3: Load Diagram (ILFP 30 and 40)	15
Figure 4: Hand Held Remote Control with Plug & Socket Wiring	19
Figure 5: Lube Points.....	23
Figure 6: Power Pack (Side View)	24
Figure 7: Power Pack (Top View)	24
Figure 8: Main Wiring.....	31
Figure 9: Hydraulic Schematic	36

List of Tables

Table 1: Maintenance Schedule	20
Table 2: Recommended Hydraulic Fluids.....	24
Table 3: Warranty Coverage Schedule	40

Company Information:

Company Name: _____

Advisor Name: _____

Vehicle Year Make & Model: _____

Liftgate Information:

Liftgate Serial Number: _____

Liftgate Model Number: _____

Date of Purchase: _____

Date of Installation: _____

Thank you for choosing INTERLIFT Liftgates.

1. Manual Updates

Revision	Description
v1.6	<ul style="list-style-type: none">• Changed the logos, from Palfinger to Interlift

2. Important Notes

2.1 Attention

Before starting any operations of the liftgate, please read and understand this OWNER'S MANUAL. Its intention is to act as a guide for the operation personal as well as to give help with preventive maintenance but does not take place of unauthorized usage or repair by unqualified personnel.

Please contact your nearest INTERLIFT Liftgates distributor or INTERLIFT Liftgates in California or New Jersey for assistance if you have questions regarding installation, operation or maintenance.

This owner's manual applies to the following models: **ILFP Slide Units 30, 40**



This is the safety alert symbol. It is used to alert you to potential personal injury hazards. Obey all safety messages that follow this symbol to avoid possible injury.

2.2 Important Notes

The INTERLIFT Liftgates ILFP model is an electro-hydraulically driven lift gate, designed to be stored underneath the truck or trailer for ultimate dock loading as well as offering up to 6-1/2 feet platform.

The Hydraulic Power Unit (HPU) is easily accessible for service and exchange. The whole assembly slides out and can be serviced at that point. To exchange the Hydraulic Power Unit (HPU), two hoses and the battery cables need to be disconnected.

The platform folded in half is supported by two torsion springs, each on one side, one support folding the other unfolding operation. The platform in a stored position acts as the under ride guard. Lifting actions are carried out by hydraulic cylinders mounted on the lift arms.

The gate is equipped with swing fixtures mounted to the bottom on each lift cylinder. This enables the platform to lower down the tip towards the ground.

The hydraulic cylinders are equipped with solenoid operated valves located at the port of each cylinder which prevents the platform from lowering accidentally unless the operator is activating the controls. This system also enables you to store the lift gate without a separate platform latch.

The piston rods are treated against corrosion. The HPU is equipped with a built-in pressure relief valve, which prevents overloading when lifting.



The valves do not prevent overloading of the platform when lowering or tilting down.



The electric supply is taken from the vehicle battery. If the vehicle battery is not sufficient or not existing (like on trailer units), an auxiliary battery kit needs to be installed. The electric control power is protected via a 20 Amp fuse and an on-off switch. The switch has L.E.D. lights indicating when the control power is on. (Trailer application has an on-off switch located in the lockable control box or at the auxiliary battery box).

The liftgate is operated from an outside control box which is located on the curbside of body. Foot controls are optional, which enables the operator to handle the cargo and operate the lift by foot. A variety of different product options can be purchased with the INTERLIFT Liftgate as well.

2.3 General Information

REMEMBER!

It is the fleet manager's responsibility to educate the operator on the liftgate and its intended use. The operator's attention should be drawn to the permitted load limits and an understanding of the operation to ensure the safety throughout the operation.

ONE-MAN OPERATION!

Never let an "outsider" operate the liftgate while you are handling the cargo.

A "misunderstanding" can result in serious personal injury.



In the interest of safety it is important that all operating personnel properly understand the functions of the lift gate, possible hazards, dangers, the load limits and load positioning for that specific unit.

IMPORTANT NOTICE!



Before the operator uses the lift gate, they should be thoroughly familiar with the lift's functions and usage according to the following:

1. Improper operation of this lift can result in serious personal injury. Do not operate unless you have been properly instructed, have read and are familiar with the operation instructions. If you do not have a copy of the instructions please obtain them from your employer, distributor or lessor, as appropriate, before you attempt to operate the lift.
2. Be certain the vehicle is properly and securely stopped before using the lift.
3. Always inspect this lift for maintenance or damage before using it. If there are signs of improper maintenance, damage to vital parts or slippery platform surface, do not use the lift. Do not attempt your own repairs unless you are specifically trained.

4. Do not overload. See the Rating Label on the unit for the rated load. Remember that this limit applies to both raising and lowering operations.
5. Each load should be placed in a stable position as near as possible to the body of the truck/trailer.
6. Never stand in, move through or allow anyone else to stand in or move through the area in which the lift operates, including that area in which a load might fall.
7. This is not a passenger lift. Do not ride the lift with unstable loads or in such a manner that a failure would endanger you. The lift is not equipped with a back-up system to prevent falling cargo in the event of a failure.

The maximum loads must be observed and followed!



IMPROPER USE



It is not permitted to use the Liftgate:

- As an elevating work platform
- To push loads
- To carry people (Only the operator may travel on the platform)
- To clear snow

Please read through the operational and technical description of this INTERLIFT Liftgate.

Thank you for choosing INTERLIFT Liftgates.

3. Safety Information

This manual follows the Guidelines set forth in "ANSI Z535.4-2007" for alerting you to possible hazards and their potential severity.

DANGER

! DANGER indicates an imminently hazardous situation which, if not avoided, **will result** in death or serious injury.

WARNING

! WARNING indicates potentially hazardous situation which, if not avoided, **could result** in death or serious injury.

CAUTION

! CAUTION indicates a potentially hazardous situation which, if not avoided, **may result** in minor or moderate injury.

CAUTION

CAUTION without the safety alert symbol is used to address practices not related to personal injury.

(In this manual we use it to alert you to potentially hazardous situation which, if not avoided, may result in property damage.)

NOTICE

NOTICE without the safety alert symbol is used to address practices not related to personal injury. *(In this manual we use it to alert you to special instructions, steps, or procedures.)*

⚠ WARNING

Improper operation of this liftgate may result in severe personal injury or death. DO NOT operate unless you have been properly instructed, have read and are familiar with the procedures in this manual. We have designed this manual to illustrate the steps needed for the basic operation of this ILFP liftgate. It also provides safety information and simple preventive maintenance tips.

NOTICE

This manual is not intended for use as a repair or troubleshooting guide. Repairs should be performed by an INTERLIFT Liftgates Authorized Service Center.

This Manual has been designed for use in conjunction with the ILFP series liftgate only which is designed for different capacities. You have different options to determine the type of your Liftgate:

- 1) Refer to the serial number tag on the Liftgate.
- 2) Ask your employer or lessor.
- 3) Call your INTERLIFT Liftgates Authorized Service Center for assistance.
- 4) Call INTERLIFT Liftgates for assistance in the USA at 888-774-5844. You can also contact INTERLIFT Liftgates by fax (562) 924-8318, or on the internet- www.PALFINGER.com

If you are facing any problems or are in need of repair, contact INTERLIFT Liftgates for information regarding experienced and trained Authorized Service Center in your area.

Replacement manuals are available, just call us & order your manuals for FREE.

4. Basic Parts in Detail

4.1 General View of Liftgate

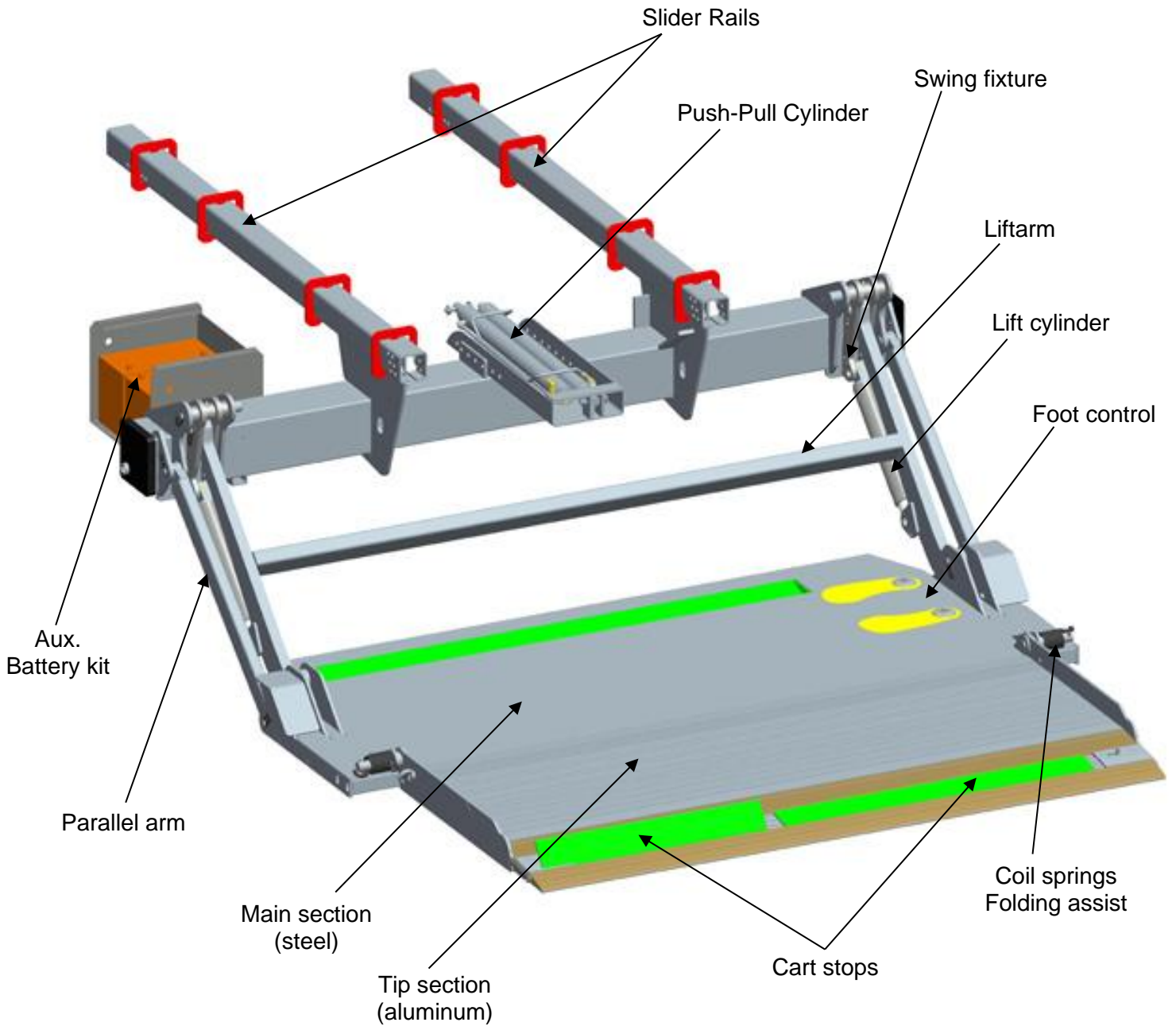
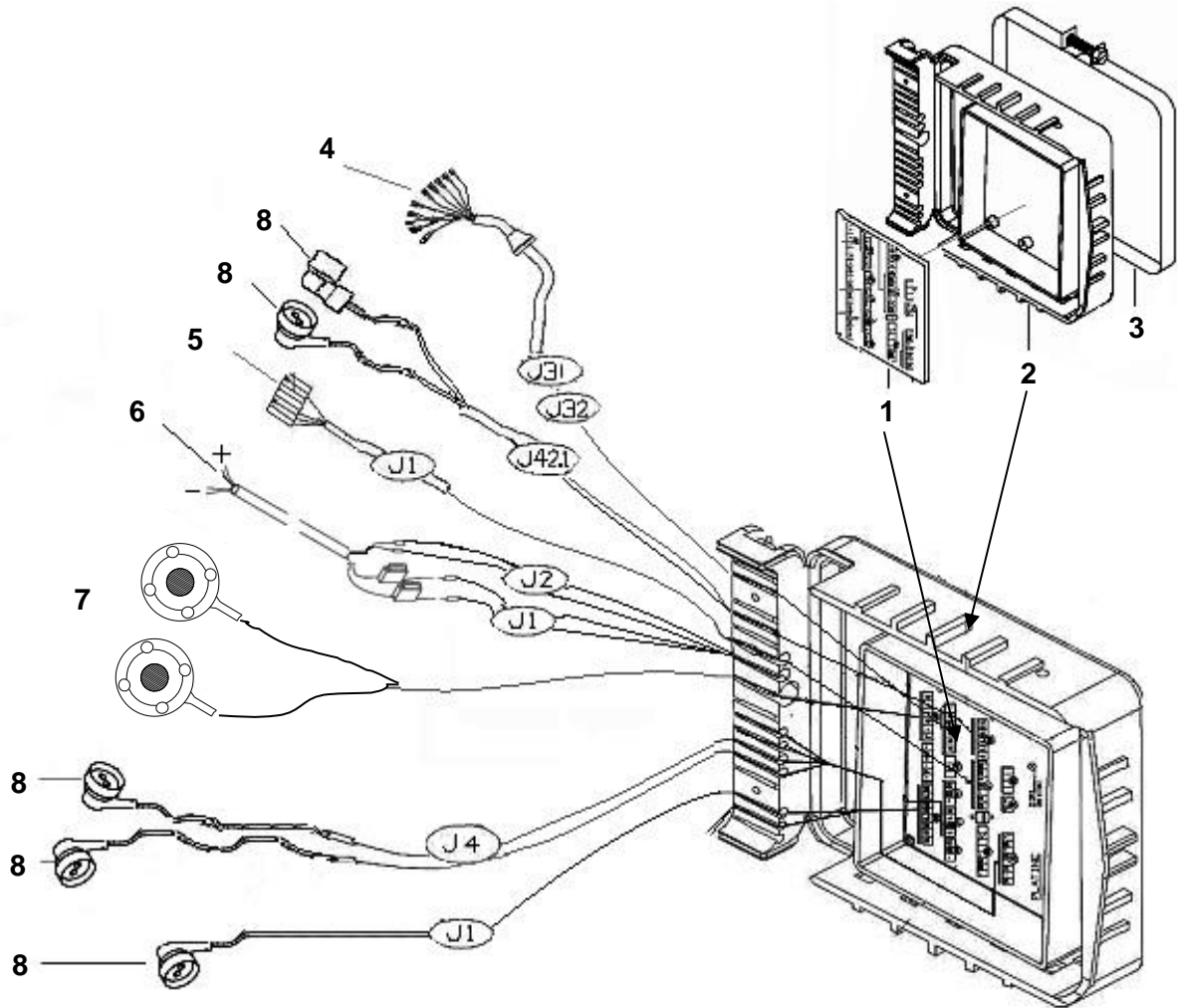

Figure 1: ILFP Slide lift

4.2 Circuit Board Connector Cables



No.	Description	Part No.
1	PC- board <i>K plus</i>	P-200 7193UK
2	Cover with hinge - for control system	P-200 7474
3	Clamp for cover	P-201 0169
4	Wire harness for control box (J30+J32)	P-200 7410
5	Wire harness for power pack (J1)	P-201 0018
6	Wire harness for circuit board power (J1+J2)	P-200 7406
7	Wire harness for foot control (J3)	P-133 0945
8	Cable for solenoid valve (J1), (J4), (J42.1)	P-6725 4198

4.3 Control Box

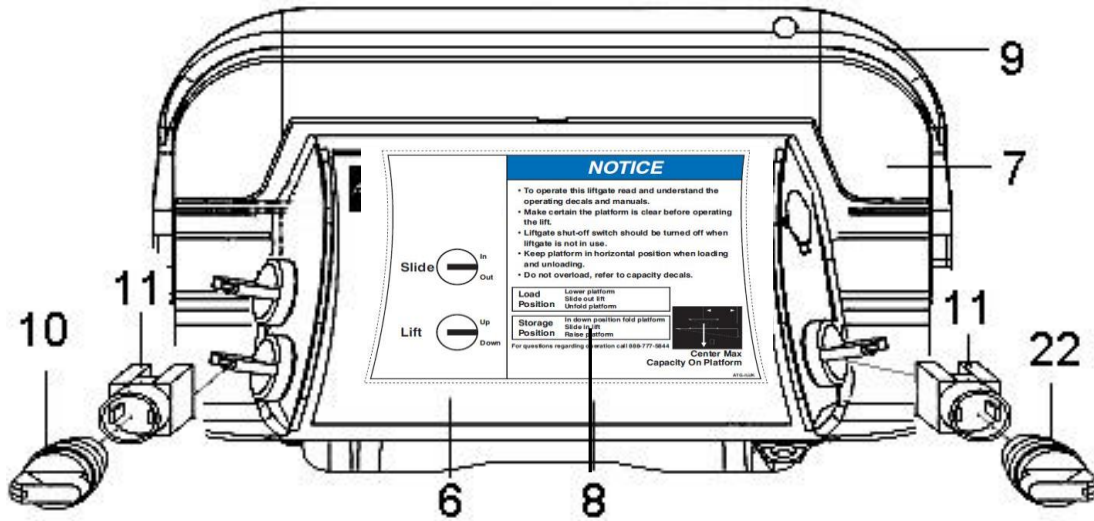

No.	Description	Part No.
6	Control box with PC-board and harness	P-200 9304
	Control box with cable (without PC-board)	P-200 7415
7	Complete outer plastic box	P-200 9205
8	Operation label	ATG-ILUK
9	Flip down lid	P-200 7476
10	Momentary turn knob	P-200 7456
11	Contact block	P-200 7457
22	On- off switch	P-200 9186

4.4 Flush mounted control (optional)

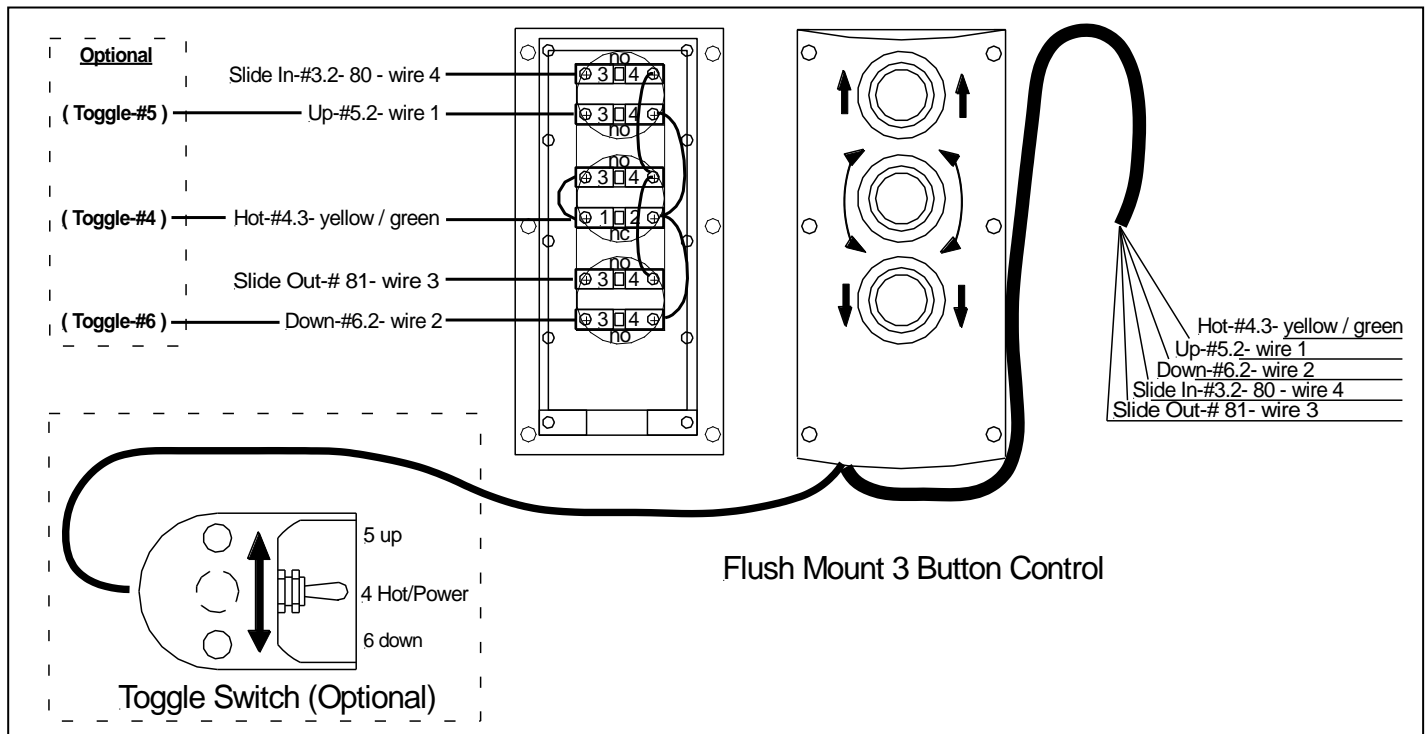

5. Maximum Load and Placing of Load on Platform

All INTERLIFT Liftgates are rated up to a maximum load. The point of maximum load is rated at a defined distance. The center point of maximum load is at 30" for all ILFP lift gates from start of Truck or Trailer Body, as shown in Figure 2.

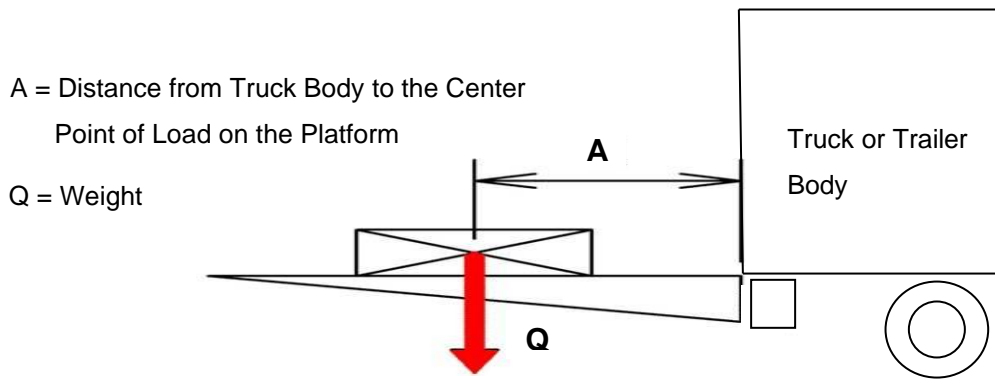

Figure 2: Center Point of Load



By increasing this distance the maximum load of the lift gate is decreasing.



An overview about the rating depending on the distance from the end of the platform, is shown in the following load diagram.

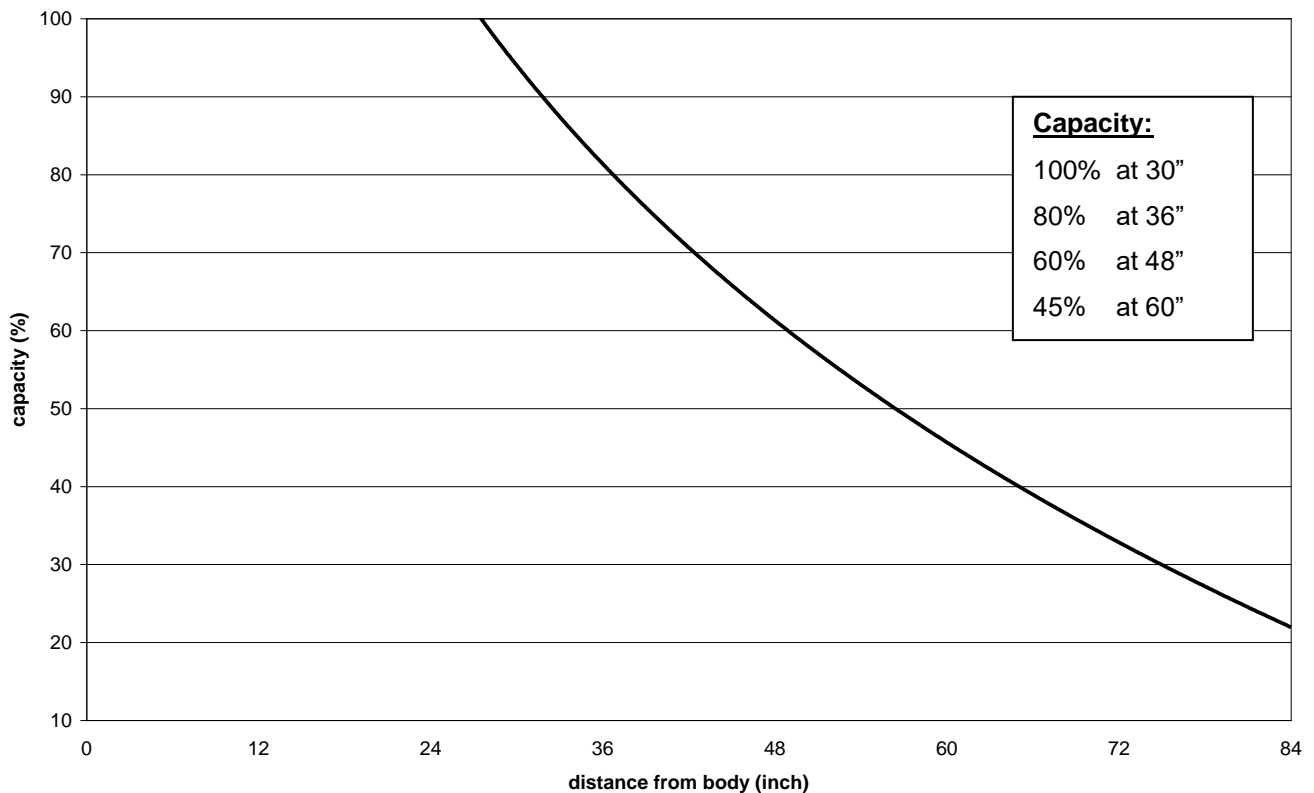

Figure 3: Load Diagram (ILFP 30 and 40)

6. Operation of Liftgate

Before use: All lift gate functions can be controlled with the 3-button control box, which is mounted on the curb side of the truck or trailer.



NOTE: Never slide platform in or out with load on the platform.

6.1 Operating the ILFP with Control Box

1. Turn on the liftgate by rotating the ON/OFF-button on the right hand side of the Control Box
(for different setup of on/off switch check for switch in Cab)

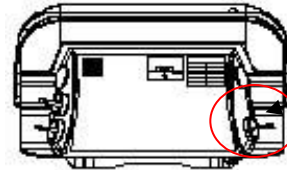

2. **Lowering down**
By rotating the bottom button **clockwise/down** gate will lower out of its storage position

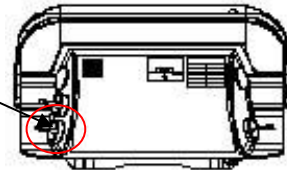

3. **Slide out the liftgate**
Rotate the top button **clockwise/down** to slide out the gate completely until it hits the slide stops at the end of the rail.

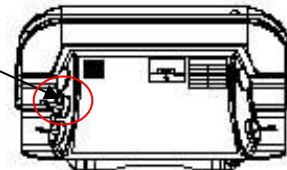

4. Unfold the platform manually by using the straps.

5. **Fold the platform for storage**
Lower down the platform to about 3" off the ground.
To fold the platform, **flip** the tip section onto the main section.

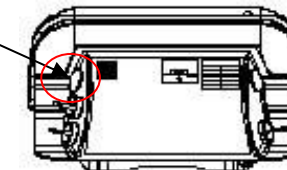

6. **Sliding in**
Rotate the top button **counterclockwise/up** to slide the lift gate underneath the vehicle until the gate is in its final position and does not slide further back.

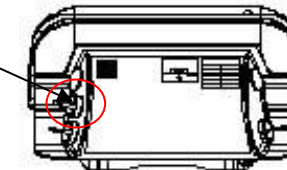

7. **Raising up**
By rotating the bottom button **counterclockwise/up** gate will raise up into its storage position.

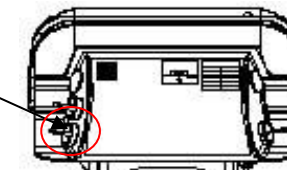

6.2 Operating the ILFP with the 3-Button flush mounted control

1. Turn on the liftgate with the on/off switch located in the cab(trucks) or at the rear end of the trailer

2. Lowering down

By pushing the bottom button the lift gate will lower **down** from its storage position.

3. Slide out the liftgate

Push the two bottom buttons to slide out the gate completely until it hits the slide stops at the end of the rail

4. Unfold the platform

Manually by using the strap

5. Operate the liftgate

Use the top (**lift**) and bottom button (**lower**) to operate the liftgate to load and unload the truck/trailer

6. Fold the platform for storage

Lower down the platform to about 3" off the ground. To fold the platform, **flip** the tip section onto the main section.

7. Sliding in

Push the two top buttons to slide the lift gate underneath the vehicle until the gate is in its final position and does not slide further back.

8. Raising up

Push the top button to raise the lift gate up into its storage position.

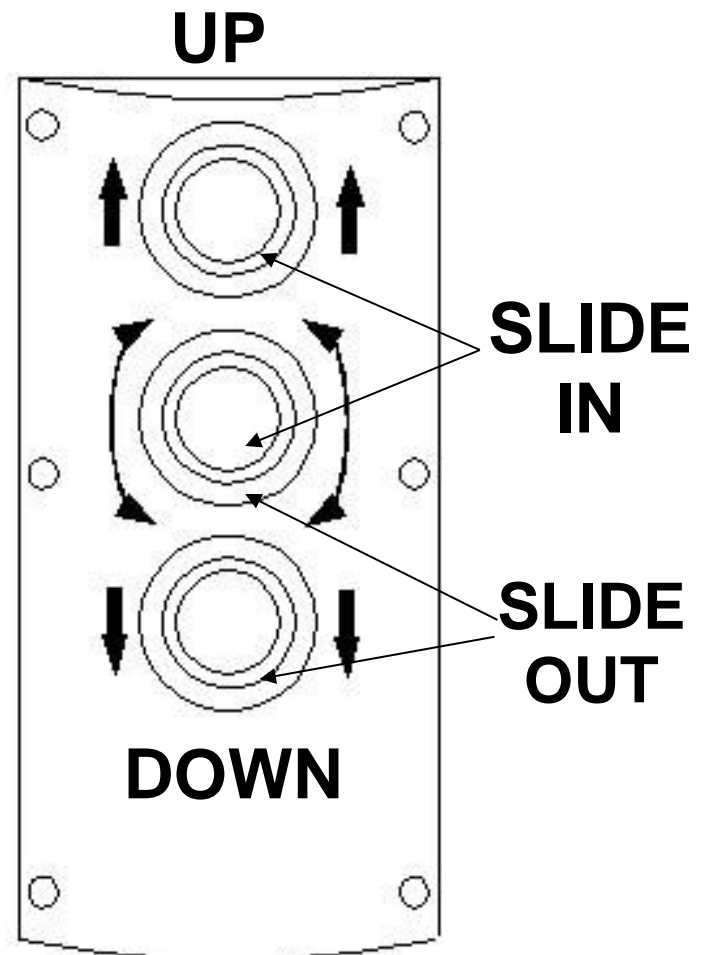

6.3 Operating the ILFP with the 3-Button flush mounted control (Easy move model)

1. Turn on the liftgate with the on/off switch located in the cab (trucks) or at the rear end of the trailer

2. Automatically lower and slide out the liftgate

Push the two bottom buttons to automatically **lower and slide out** the gate completely until the gate hits the slide stops

3. Unfold the platform

Manually by using the strap

4. Operate the liftgate

Use the top (**lift**) and bottom button (**lower**) to operate the lift gate to load and unload the truck/trailer

5. Fold the platform for storage

Lower down the platform to about 3" off the ground. To fold the platform, **flip** the tip section onto the main section.

6. Automatically slide in and store the liftgate

Push the two top buttons to automatically slide the lift gate underneath the vehicle until the gate is all the way in and has store itself into the transport position.

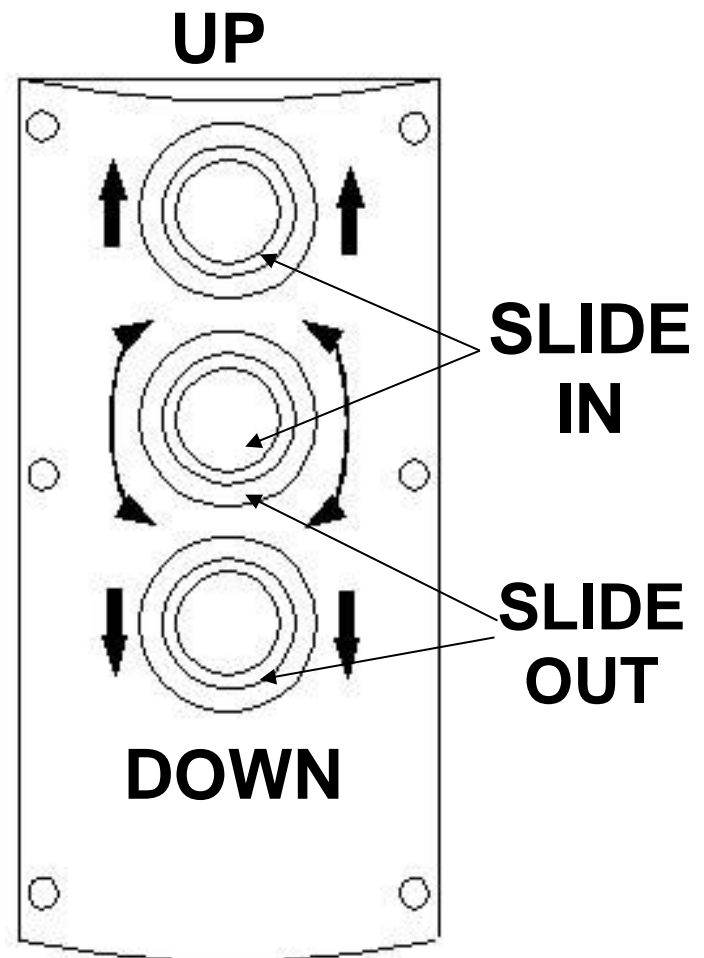

NOTICE

The gate will adjust itself to its **preset sliding position**. It will either raise or lower - depending on where the gate is – before it will start sliding back underneath the truck to assure no damage to gate or truck body.

The **Easy Move** is designed for an error free storing and deploying of your ILFP. The **Easy Move** control assures that your liftgate is always in a transport position after usage of the gate. The **Easy Move** will always store your liftgate in the highest possible position to assure no damage to truck and Equipment.

6.4 Operation by Hand Held Remote Control



Hand Controls are NOT weatherproof and are designed to be stored inside bodies in holsters or in weatherproof boxes.

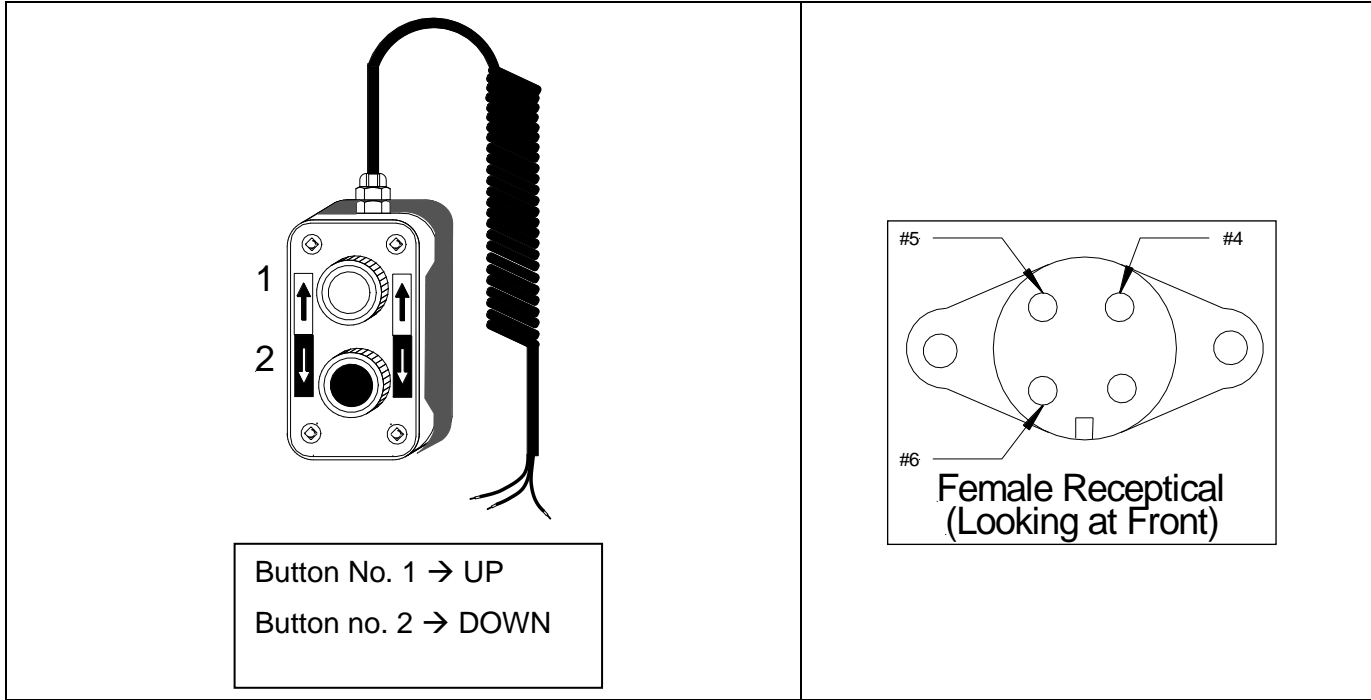

Figure 4: Hand Held Remote Control with Plug & Socket Wiring

6.5 Operation by Foot Control

DOWN:

Step on switch 1 and hold – wait between one and three seconds before you step on switch 2.

UP:

Step on switch 2 and hold – wait between one and three seconds before you step on switch 1.

IF BOTH SWITCHES ARE NOT ACTIVATED WITHIN THREE SECONDS, START OVER.

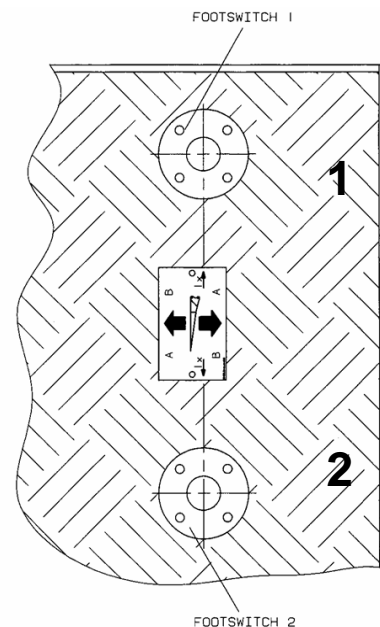

DIAGRAM NO.3:
FOOT CONTROL ON THE PLATFORM

7. Preventive Maintenance and Quick Check

The ILFP needs preventive maintenance to perform at its fullest capability. Lubricate and inspect regularly. Also, check that all details are not damaged, e.g. Hoses, cables, controls, etc.



REPAIR OR REPLACE IMMEDIATELY FAULTY PARTS



7.1 Maintenance and Care

The following inspection and maintenance should be performed at the recommended intervals depending on operation and amount of cycles or at the time when the unit shows any signs of damage or abuse. Remember that the secret to a long life of your INTERLIFT Liftgates is to maintain it through preventive care.

Recommended bases for inspection and maintenance	Depending on use	Daily	Monthly	Quarterly
cleaning	x			
general lubrication of pins and bushings				x
general lubrication of Slider Rails with WD-40 and Push-Pull Cylinder zerks with grease				x
oil level inspection				x
oil change	x			
check hydraulic hoses and pipes for leaks				x
check controls and connections				x
check pins and pin retaining bolts			x	
check batteries and connections				x
check warning labels and other safety equipment for effectiveness and visibility		x		
visual check for loose or missing parts and unusual noise during operation		x		
check lock bolts and pins for tightness				x
check complete function of gate		x		
check mounting brackets of lift gate to frame for cracks or damage visually		x		

Table 1: Maintenance Schedule

7.2 Trailer to Tractor Connection Test

CROSS TEST ON ENTIRE CHARGE SYSTEM SINGLE POLE PLUG SET UP

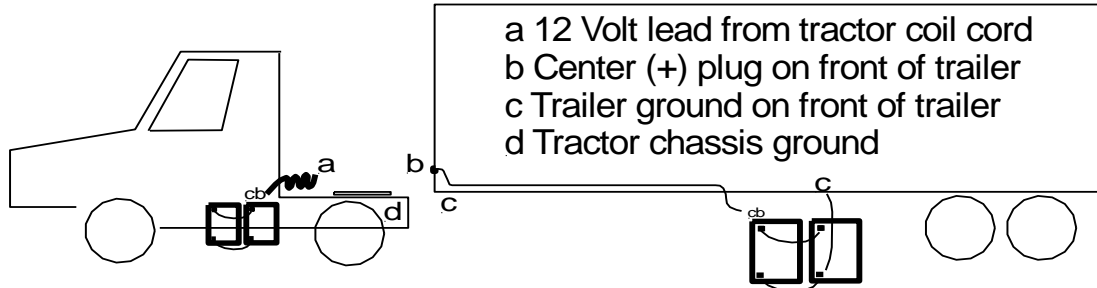

Testing of full system using a battery load tester:

Start with testing each individual battery on both tractor and trailer before proceeding to check the system:

Tractor Test:

1. Ground battery load tester on tractor chassis point (d)
 Hook up positive load tester cable on positive pole of single pole plug at end of tractor coil cord (a)
 Run load test- This will test entire circuit on tractor including ground from batteries to tractor chassis

Trailer Test:

2. Ground battery load tester on trailer chassis (c)
 Hook up positive cable on positive pole of single pole plug receptacle on trailer (b)
 Run load test - This will test entire circuit on trailer including circuit breakers & ground between trailer batteries and trailer chassis.

Tractor and Trailer charging system test while connected:

3. Ground battery load tester on tractor chassis (d)
 Hook up positive cable on positive pole of single pole plug receptacle on trailer (b)
 Run load test- This will test entire circuit on tractor - trailer including ground between tractor and trailer and circuit breaker on trailer.

A simple low amp voltage test at the front of the trailer or at the tractor will not show insufficient connections or ground problems

7.3 Lubrication

Properly lubricated, the INTERLIFT Liftgates ILFP model will ensure longevity. Therefore, lubricate the lift at the same time as the truck/trailer. Grease more frequently if the liftgate is heavily used. The liftgate should be greased every 500 cycles (depending on use – estimated every 3 month).

Check the oil level in the tank. The level should be between the two marks 5 and 7 with platform in stored position. Use a good quality of hydraulic fluid, ISO 32. Change oil at least once a year, preferably in the fall before the winter is getting closer. The operation of the lift gate will accumulate condensation and some dirt which can interfere with the lift gate functions.

7.3.1 Lubrication Plan

All bearing points must be lubricated in accordance with the maintenance intervals.



Make sure NOT to lubricate the rails with grease as it catches all dirt and mud.

Avoid this by using WD-40 for rail lubrication.



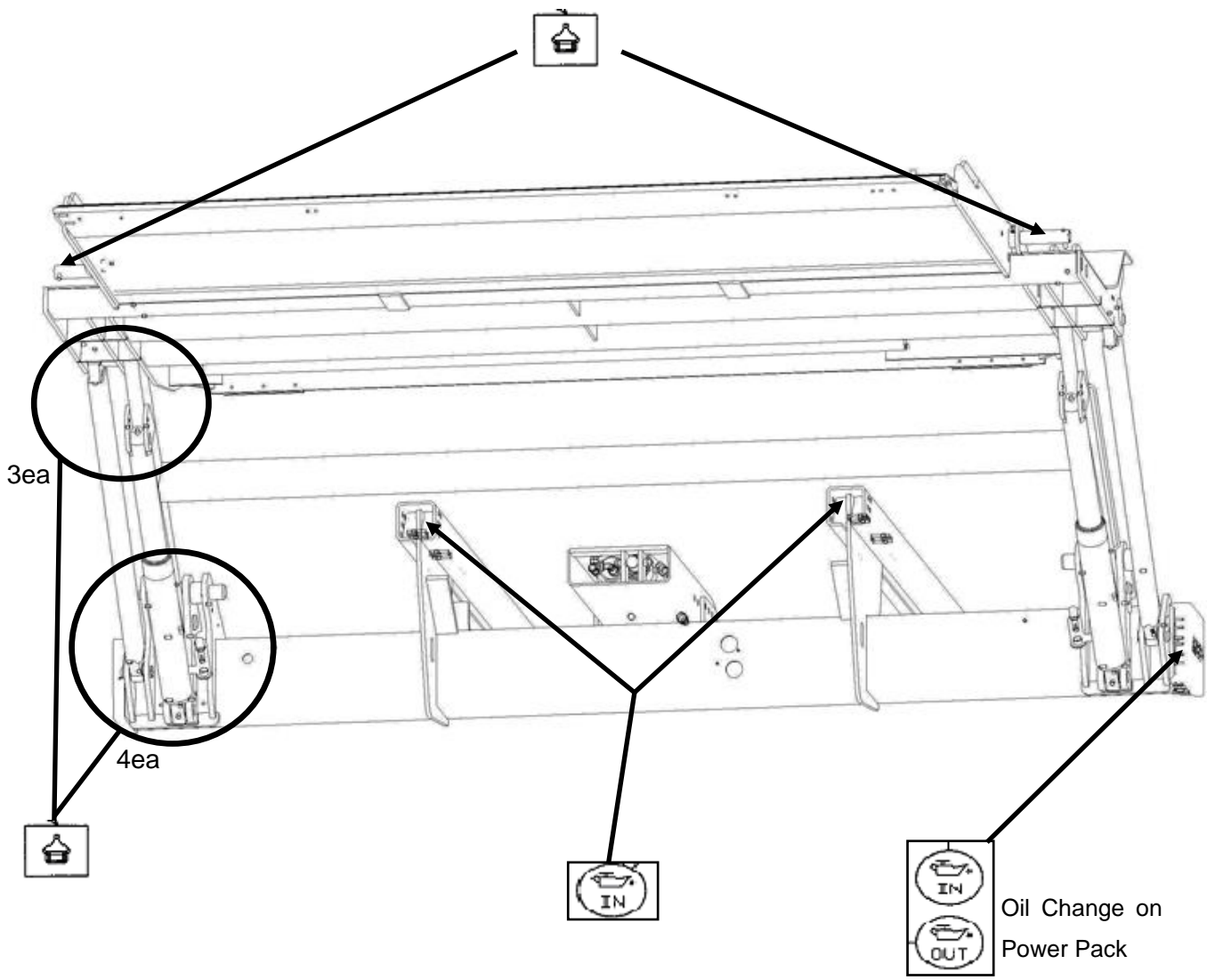

Figure 5: Lube Points



Location of Grease Zerks (8 on each side, 16 total)



Oil level in the power pack tank (see marking inside of power pack reservoir)



Platform hinges, Slide Rails and optional Cart Stops (use WD-40 spray for lubrication)

7.3.2 Checking and Changing the Oil

Check the quality of hydraulic fluid. Take the following steps to change the oil. In stored position, lower gate to ground (for Easy move model keep gate in stored position) and remove lock bolt. Pull the power pack out until you can reach the oil filler cap. Unscrew the oil drainage bolt (bottom of tray) and let the fluid drain out of the reservoir into an approved container. If the reservoir is empty, fill it up with hydraulic oil, as shown on table 2.

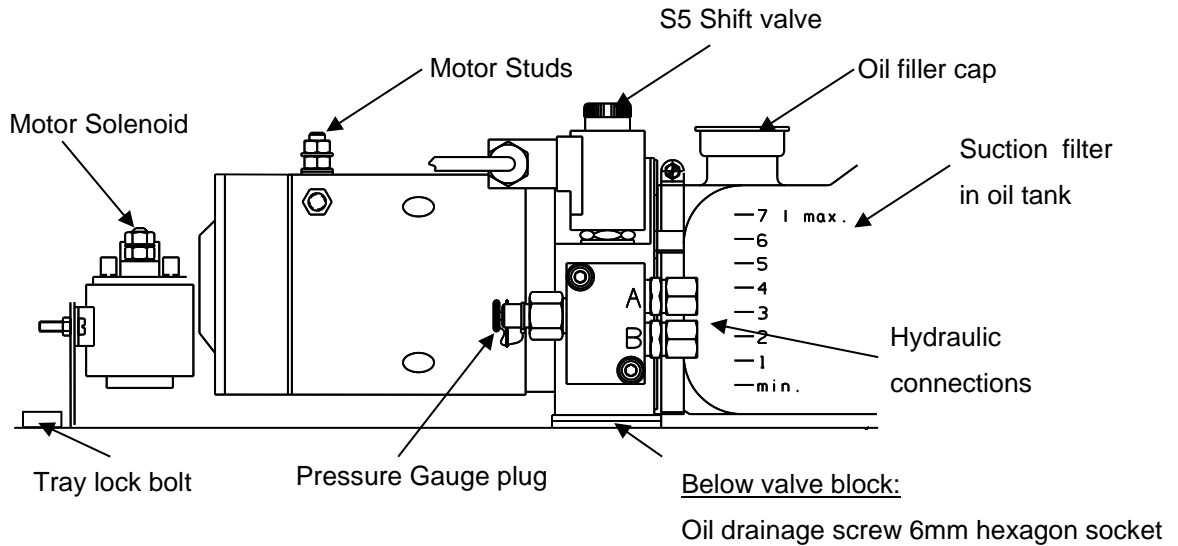

Figure 6: Power Pack (Side View)

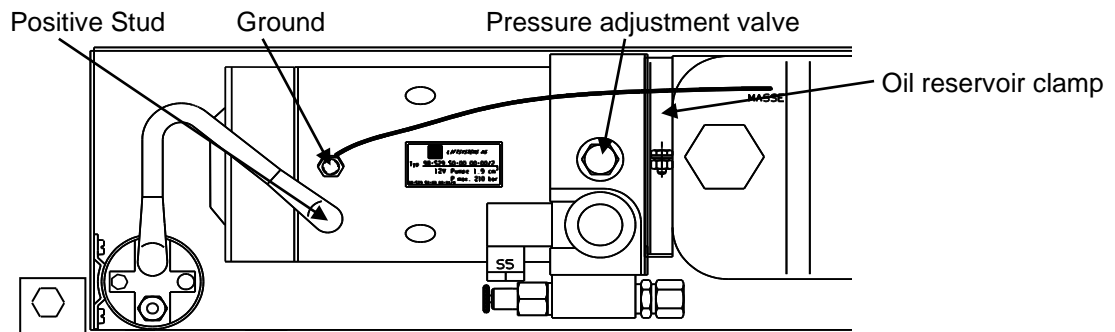

Figure 7: Power Pack (Top View)

7.3.3 Recommended Hydraulic Fluids

TEMP. RANGE	BRAND	
-10 TO 150 F	EXXON	UNIVIS J26
	MOBIL OIL	DTE 13M
	CHEVRON	AW MV32
	ROSEMEAD	MV 150 (32)
-50 TO 150 F	MOBIL	DTE 13M
	SHELL	AERO FLUID 4
EXTREME COLD TEMPERATURE:	USE MILITARY SPEC:	MIL H5606

Table 2: Recommended Hydraulic Fluids

7.4 Decal Placement and Inspection

For operator's safety, all decals appearing in "Decal Kit" must be in a conspicuous place on control side of liftgate to be read by operator. This is typically a combination of decals on the liftgate and truck body. Please make sure to place the maximum capacity decal (C) on driver and curb side.

- (A) 1 ATG-URGWA - Urgent warning: Elevating gate instructions
- (B) 1 ATG- SWILFP - Main Operation (Control Box)
- (C) 2 ATG-XXXX - Max. Capacity (please check the serial number plate to find out your specific capacity)
- (D) 1 ATG-CAB - Liftgate Shut-Off (must be placed next to the Shut-Off Switch)
- (E) 1 ATG-BKR - Circuit Breaker Reset (must be located at the circuit breaker)
- (F) 2 ATG-WLH - Warning: liftgate can crush
- (G) 2 ATG-CTN - Caution: Always stand clear of platform area
- (H)) 1 ATG-RESET - Circuit Breaker Protection
- (J) 1 ATG-FT - Notice for Foot Control (if applicable)
- (K) 1 ATG-UD - Toggle Decal (next to the toggle switch, if applicable)
- (L) 1 ATG-WNG - Warning: Use handle to open (must be located underneath handle (main section))

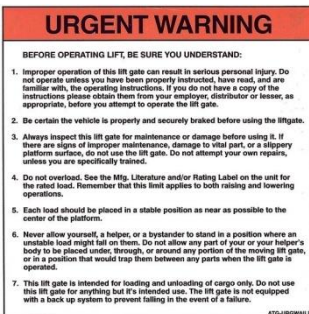

Decal - A

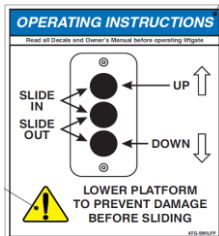

Decal - B
Version 1

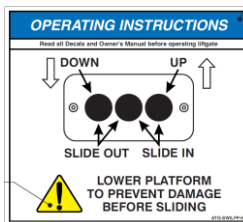

Decal - B
Version 2

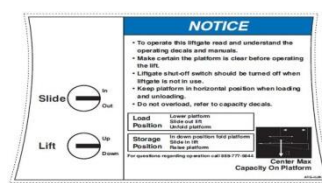

Decal - B
Version 3



Decal - C



Decal - D

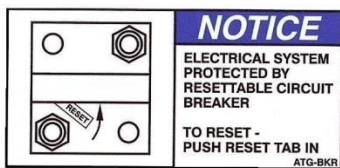

Decal - E



Decal - F



Decal - G



Decal - H

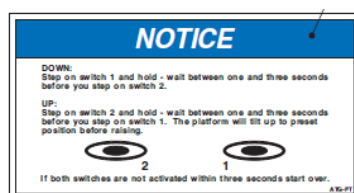

Decal - J

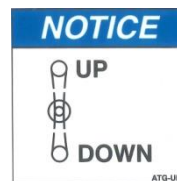

Decal - K



Decal - L

The picture below will help you to place all decals visible in order to get maximum operational safety.

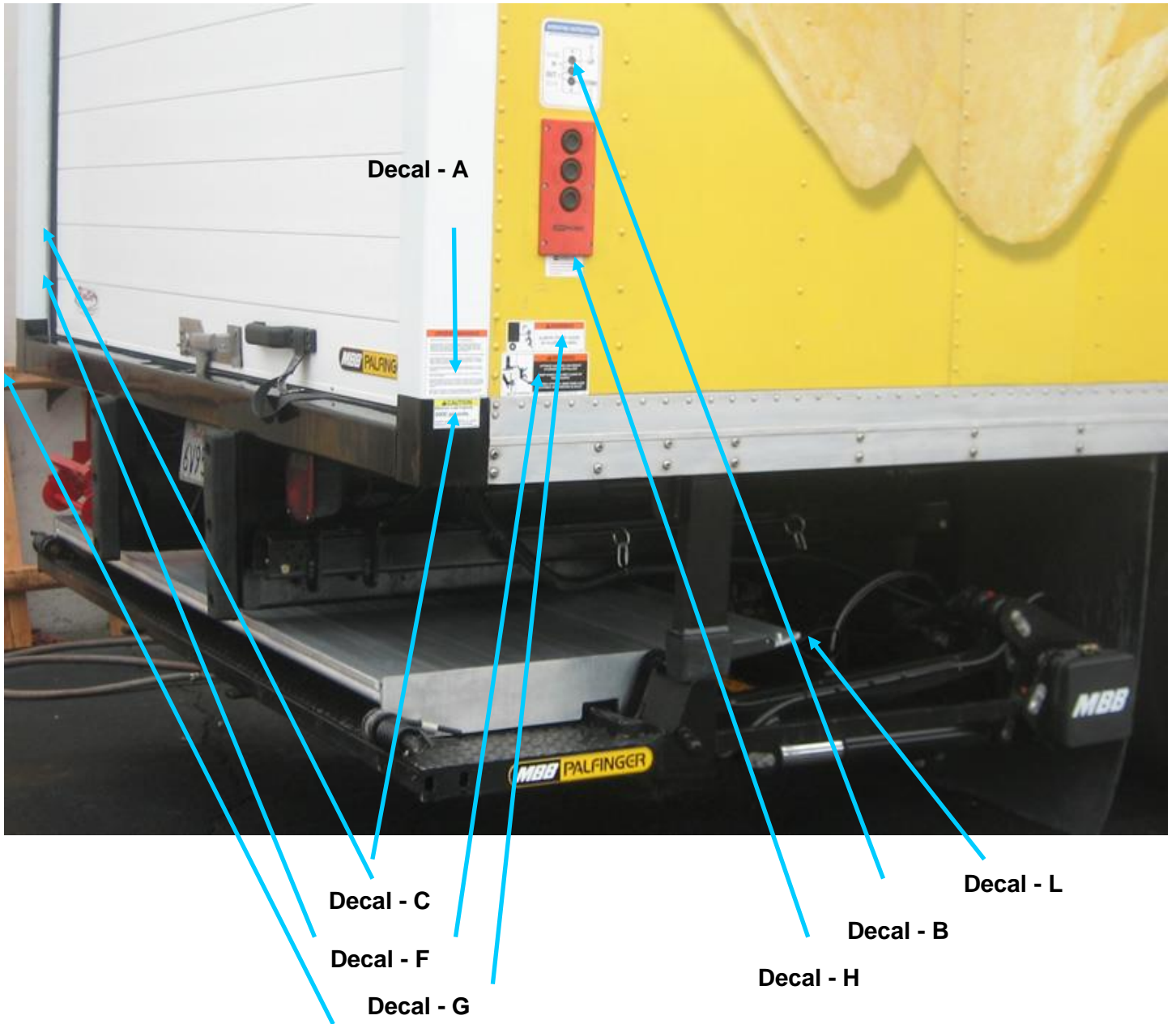

7.5 Quick Check List

1. Operate the liftgate throughout its entire operation and check for noise and damage such as bent parts or cracked welds.
2. Inspect all welds and fasteners that attach the mount frame to the truck. All pins and bolts that connect the lift arm to the mount frame and to the platform.
3. Visually inspect the hydraulic lines for damage, scratches, bending or leakage.
4. Inspect the cylinders for leakage and that the cylinder pins are secured with lock bolts.
5. Check the oil level when the platform is down at ground level. The level should fall between the markings 5 and 7 on the tank. We recommend replacing oil after the first 1200 cycles, after that on a yearly basis in the fall before winter begins.
6. Check for oil leakage around the power pack and inside mount tube. Tighten or replace components if needed. If you perform work on any hydraulic components bleed the air out of the system by operating all functions several times.
7. Check all electrical connections. Clean and protect battery terminals and check for tightness.
8. Inspect all the terminals on the solenoid-operated valves at the port of the cylinder. Lubricate the terminals for better protection from oxidation if needed. Please check the valve block on the back of the main tube and its connections additionally.
9. Grease all zerks on the lift gate and make sure they all take grease. Sometimes it helps to operate the lift gate while you do this. There are 16 zerks.
10. Test all the lift gate functions, if possible with maximum loads placed according to load diagrams.
11. Check the function of the pressure relief valve.
12. When performing daily checks and you find any kind of damage that can make the use of the liftgate dangerous, it must be repaired before using. All repairs should be made by an authorized technician. Use only original spare parts. If in doubt contact your INTERLIFT Liftgates distributor or call INTERLIFT Liftgates directly.



Do not cover up any accidents or damage; it can be dangerous for you and your co-workers.

8. Troubleshooting

ATTENTION:



Dangerous injuries possible from tools short circuiting main battery connections.



Every time you are finished troubleshooting, close the rubber cover on the curbside of the mount frame. **REINSTALL THE PLASTIC STRAP ON THE RUBBER COVER WHEN FINISHED!!**



Please check the following points before looking for faults:

- Please change oil after working on hydraulic unit (removal of valves, opening of cylinder etc.)
- There is a possibility of injury if somebody other than an authorized technician works on the electrical system!
- Injuries are possible if short circuits are caused by tools on the main battery connections.

8.1 Basic Function Check

8.1.1 LIFTGATE is completely DEAD (No Clicking or Movement at all)

1. Check the ON-OFF switch.

To activate and start operating the ILFP you will have to turn on the ON-OFF switch.

2. Check the circuit breaker at the main batteries.

Every truck has a circuit breaker on top of the main battery. If you have a trailer, you will also find an auxiliary battery kit as shown in the pictures below (“Truck Battery” and “Auxiliary Battery”).

If circuit breaker reset arm is tripped, push it back in as shown on the decal ATG-BKR next to your breaker or on battery box lid.

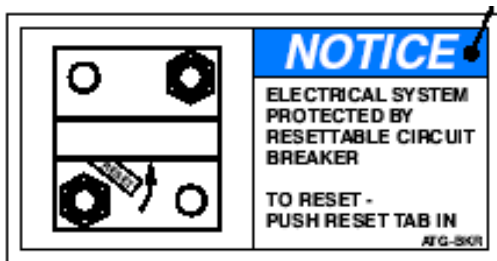
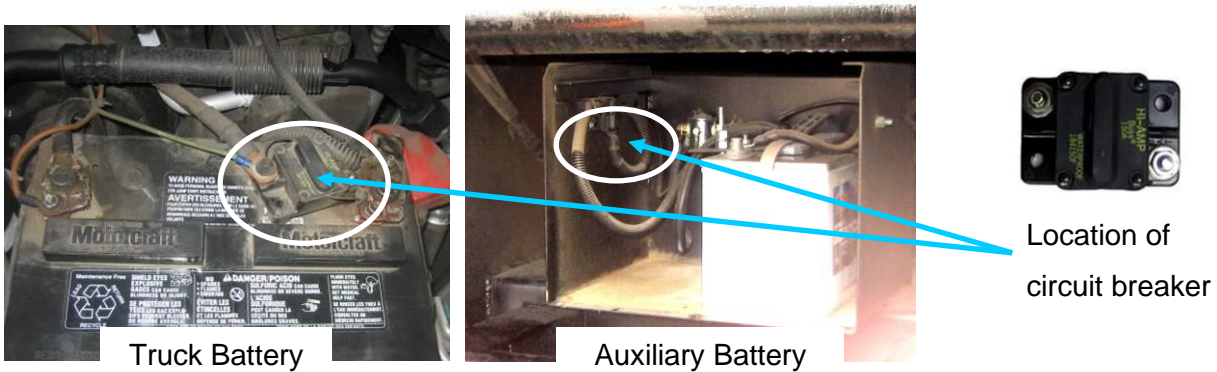

Reset your Circuit Breaker

3. Are the vehicle batteries charged?

Check batteries and the truck/trailer charging system. Start truck and run engine in fast idle for charging the batteries. If liftgate starts working, recharge batteries.

4. Check the fuse at the power pack.

In the Hydraulic Power Unit next to the motor you will find two fuses. Check for burned fuses and replace with the same type (15 amp) if necessary.



DO NOT use higher amperage fuses.

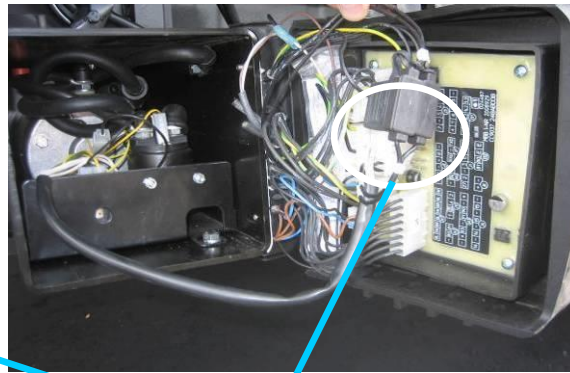
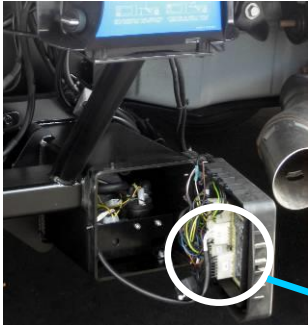

Open this cap to check the fuses

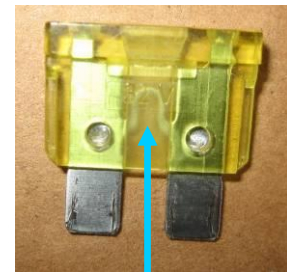

Replace fuse when metal bridge is broken

5. Is the connection to ground in power pack OK?
Is the ground connection from the tail lift to vehicle OK?
6. Check the oil level in the power pack reservoir.
7. Are there any damages on mechanical or electrical parts (such as damaged cables)?

8.1.2 ON-OFF switch on, but all functions are dead

Possible malfunctions:

1. Short in hand held remote or its wire → unplug Hand-Control.
2. Short in control box wire → remove plug J-31.

After disconnecting plugs – reboot board by unplugging J-1 for 5 seconds and plug it back in.

8.2 Electrical and Hydraulic Schematic

8.2.1 Main Wiring Diagram

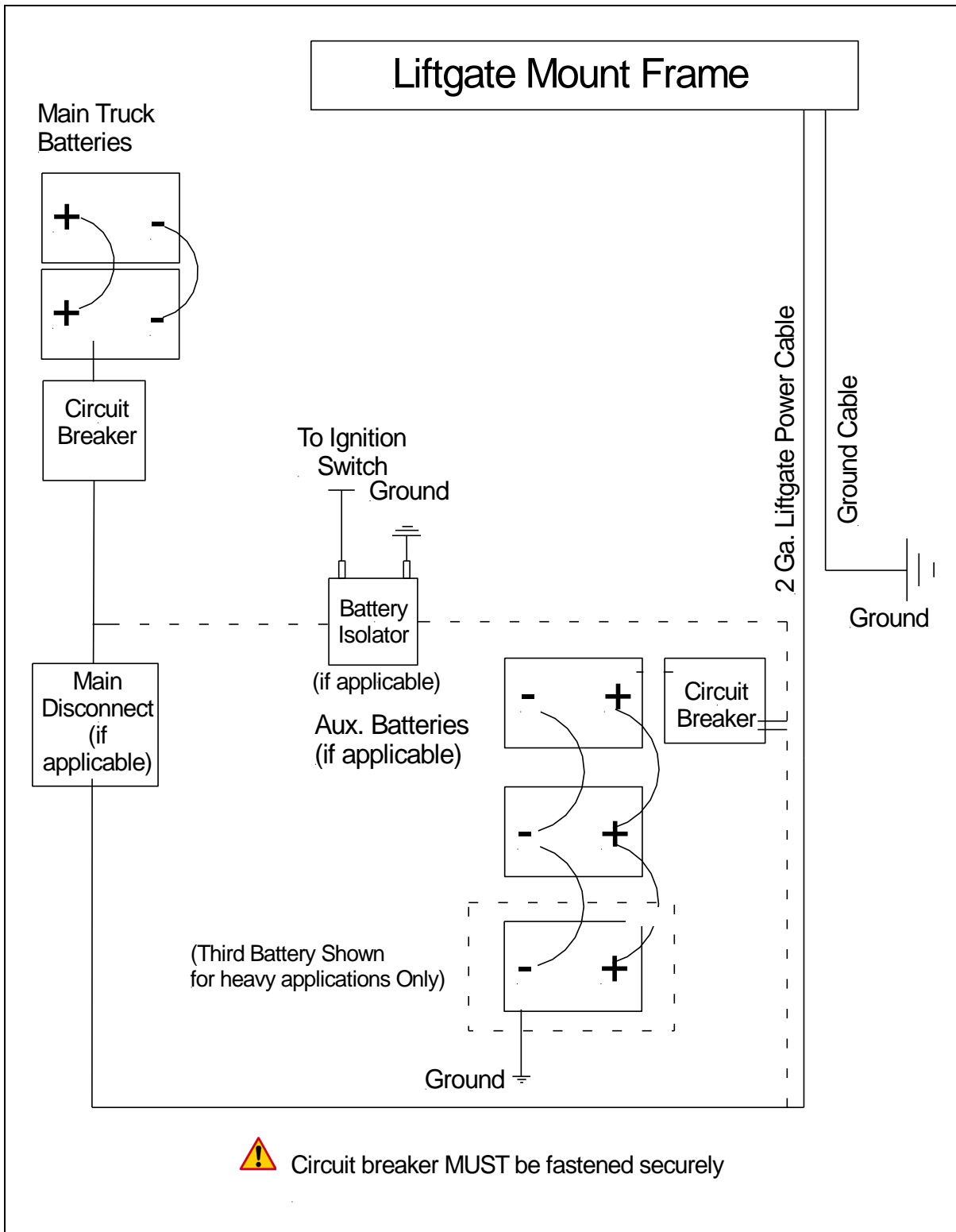

Figure 8: Main Wiring



FOLLOW DOTTED LINE IF ISOLATOR OR AUXILLIARY BATTERIES INSTALLED!

8.2.2 Electrical Schematics

8.2.2.1 Control board wiring and connector setup

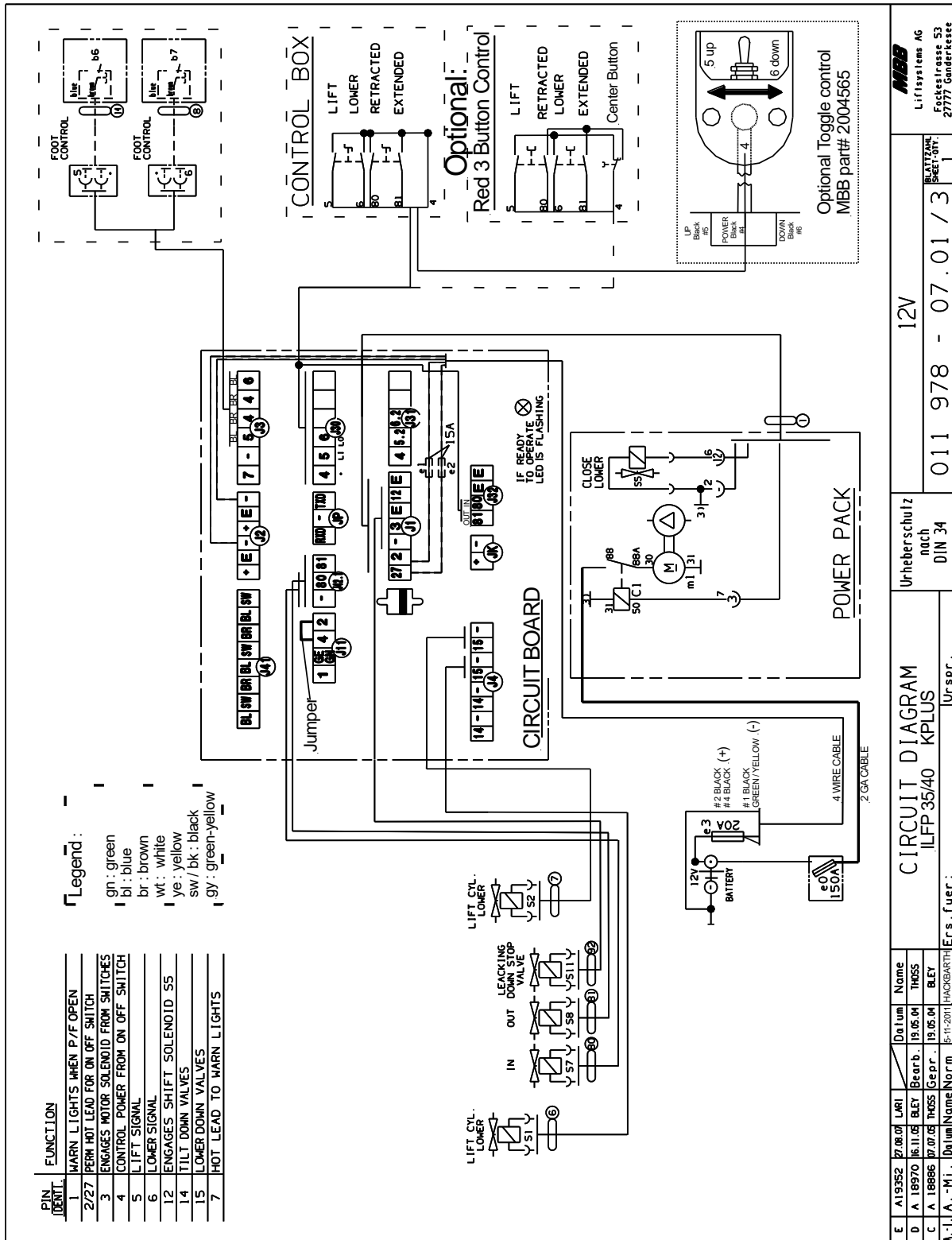

Figure 1 Control board wiring schematic

8.2.2.2 Control board plug setup

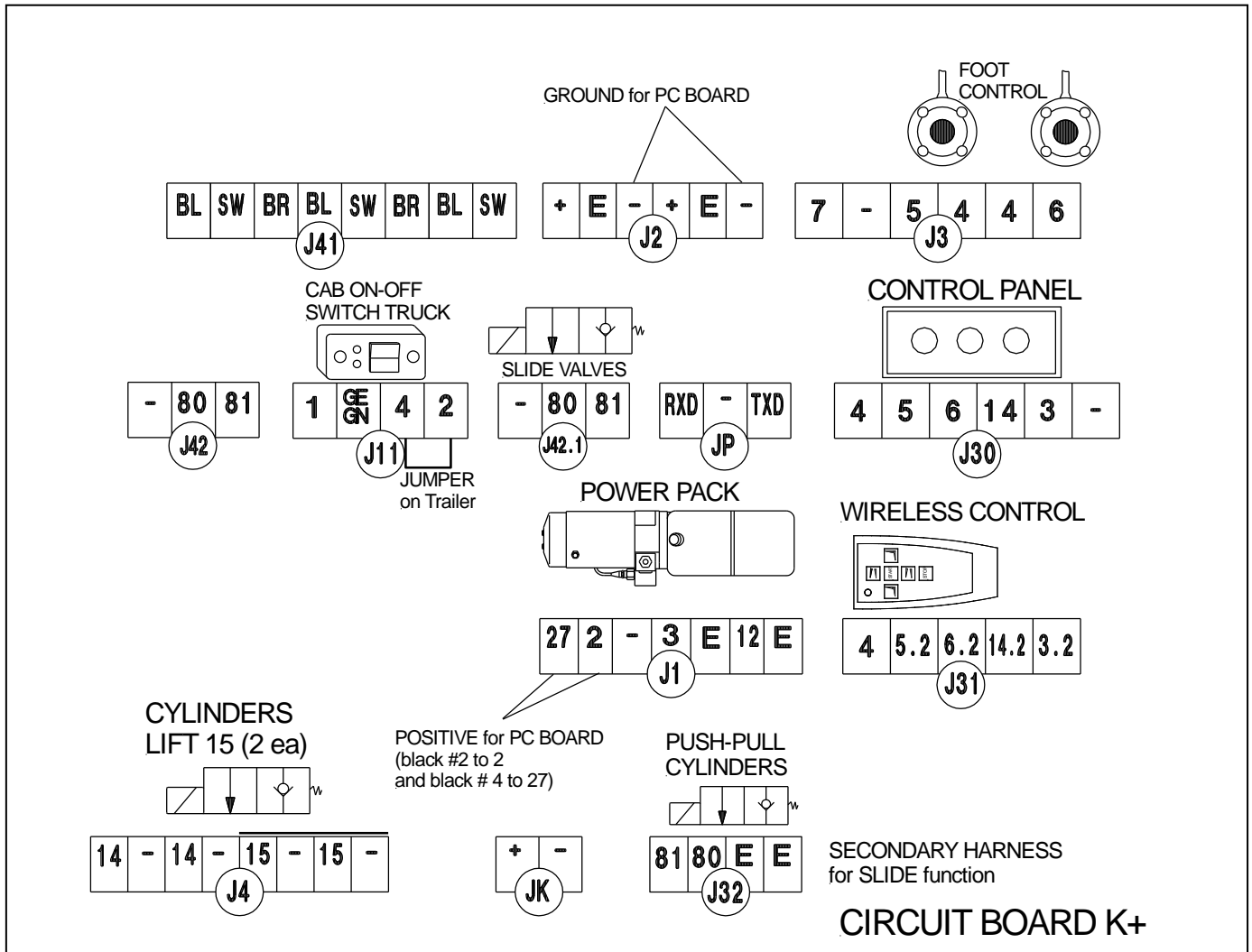

Figure 2 Plug setup on PC - Board

This graphic describes the different functions of each plug and where it is connected to. Make sure every plug is in its correct position and fuses are in good conditions.

Connector description:

- J-1: Main power input and connection to pump & motor tray
- J-11: ON-Off switch for truck setup
- J-2: Ground connection
- J-3: Platform equipment (foot controls)
- J-30: Control panel
- J-32: Control button input for slide function
- J-4: Lift cylinder- (#15)
- J-42.1: Output to Slide valves S-7 (slide in) and S-8 (slide out)

8.2.2.3 Control board wiring and connector setup (Easy move model)

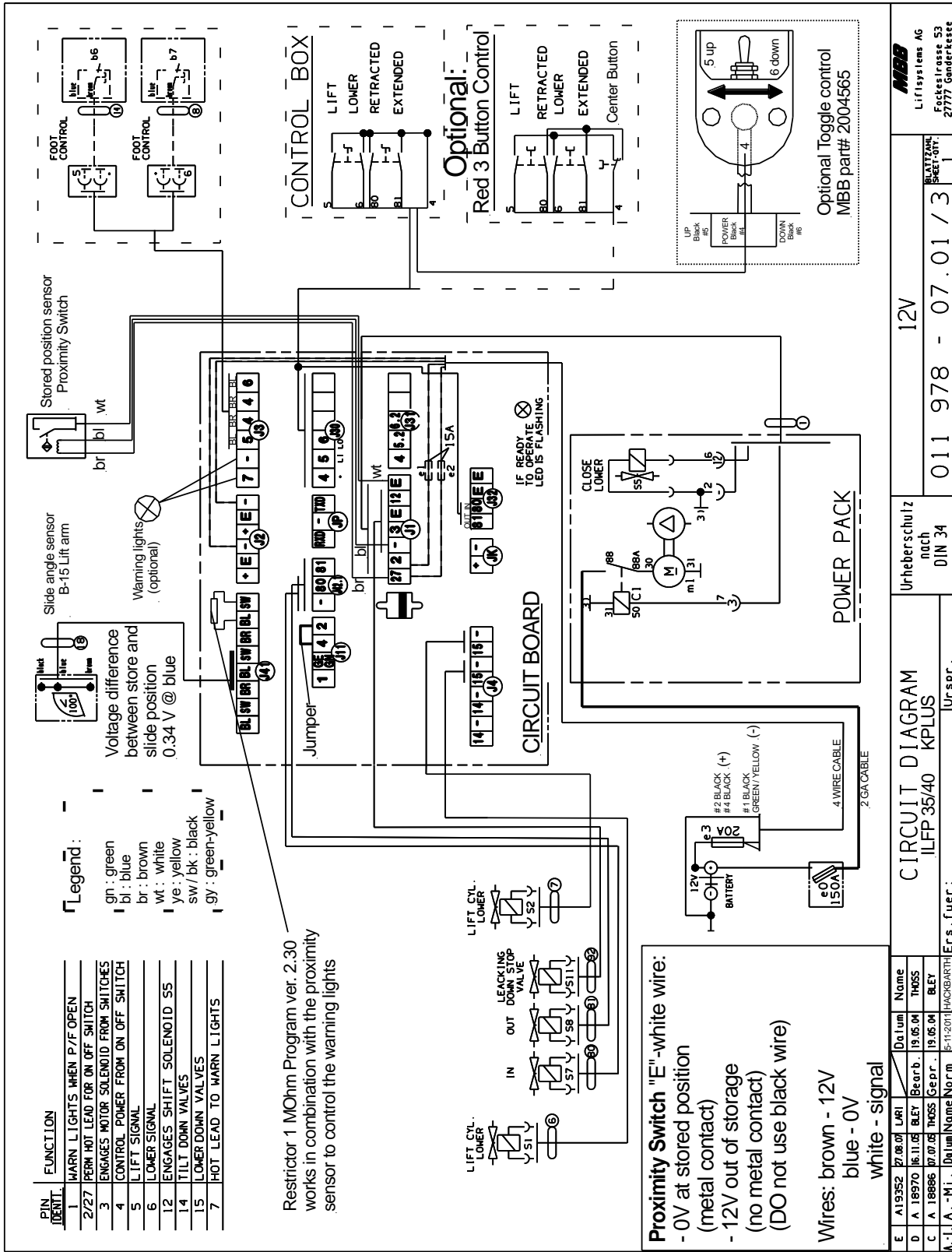

Figure 3 Electrical schematic Easy move

8.2.2.4 Control board plug setup (Easy move model)

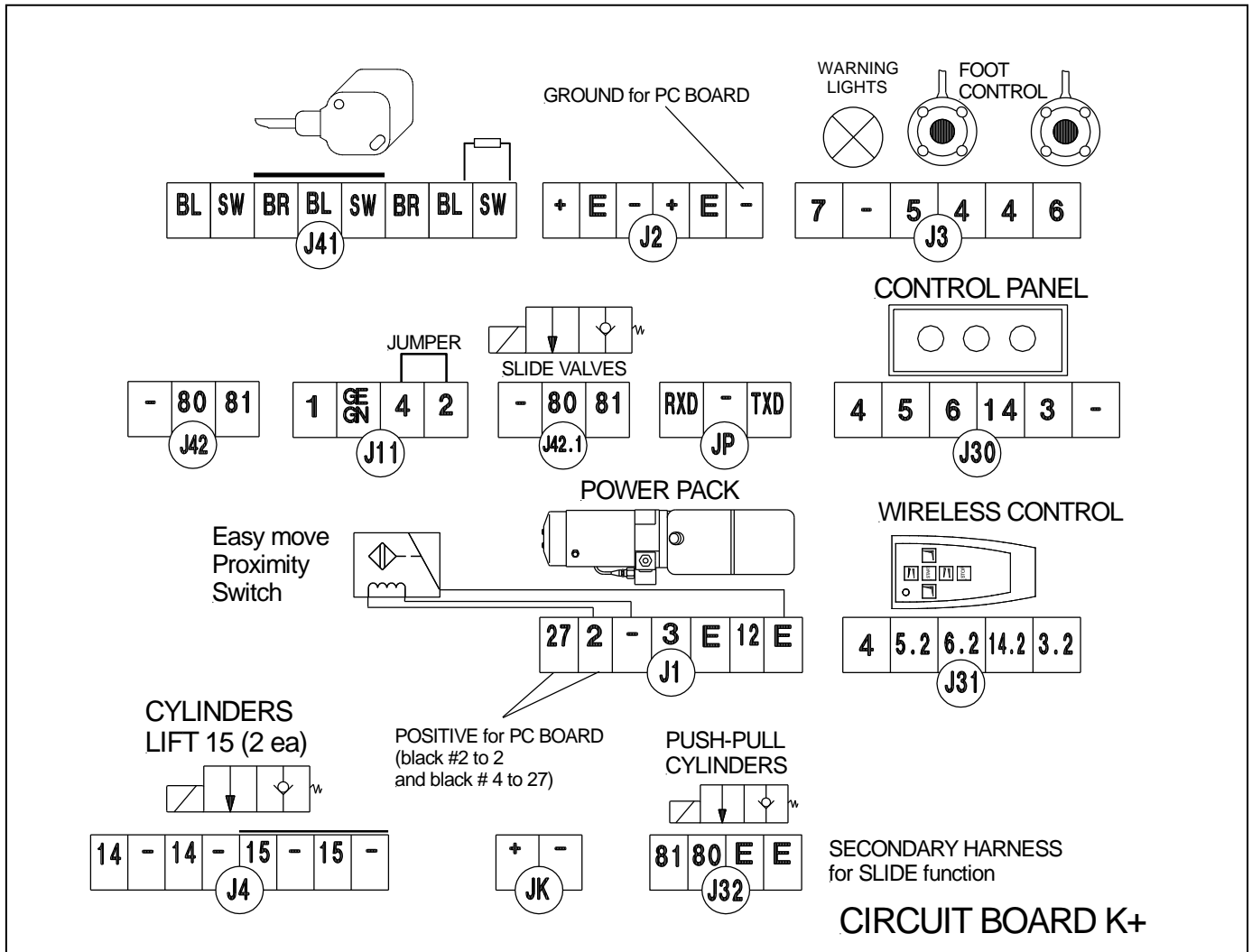

Figure 4 Plug setup on PC - Board

This graphic describes the different functions of each plug and where it is connected to. Make sure every plug is in its correct position and fuses are in good conditions.

Connector description:

- J-1: Main power input and connection to pump & motor tray
- J-1: Connection on "2", "-" and "E" for Easy move proximity switch
- J-2: Ground connection
- J-3: Platform equipment (foot controls)
- J-30: Control panel
- J-32: Control panel input for slide function
- J-4: Lift cylinder- (#15)
- J-41: B-15 Lift arm sensor for Easy move platform position control
- J-42.1: Output to Slide valves S-7 (slide in) and S-8 (slide out)

8.2.3 Hydraulic Schematic

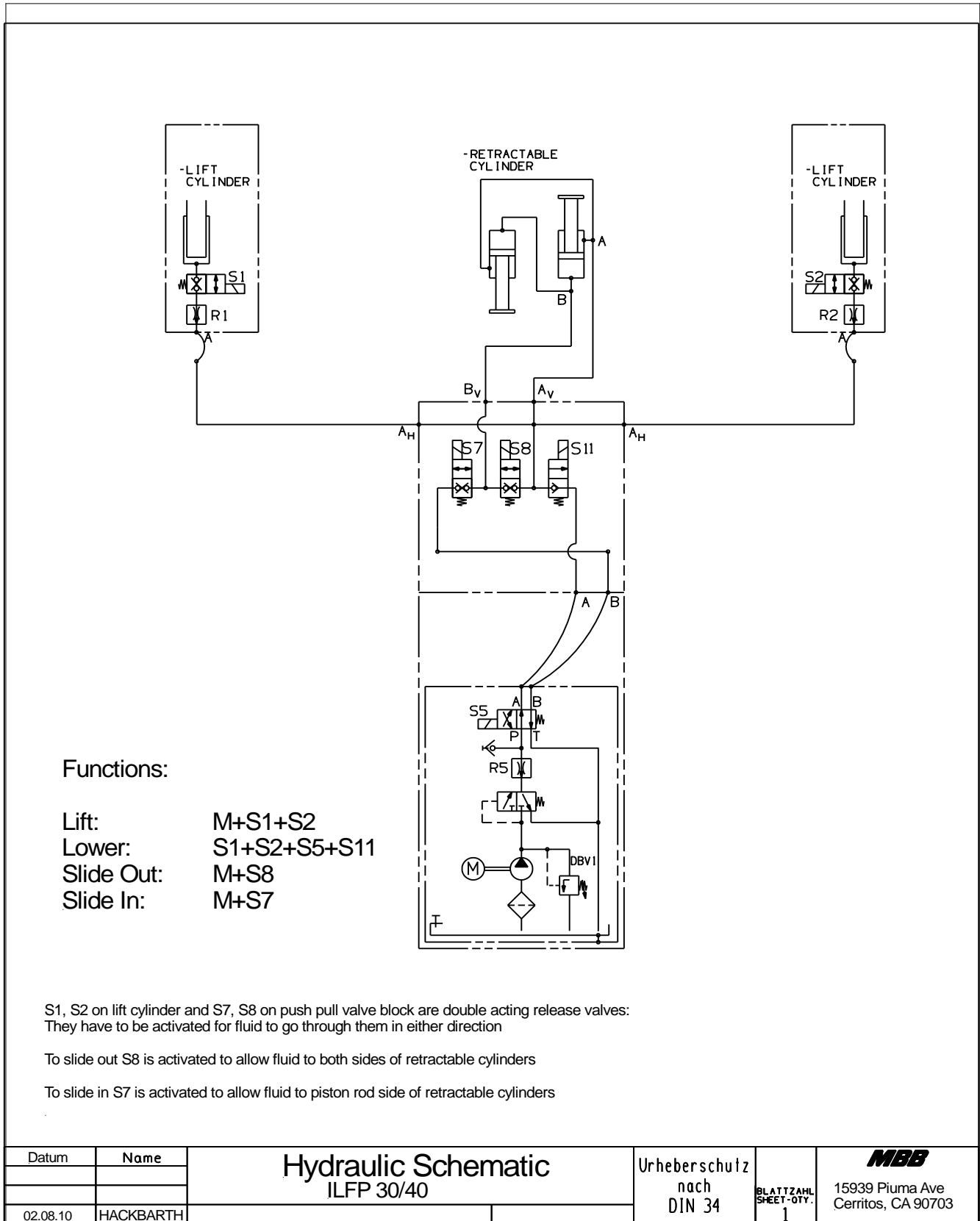

Figure 9: Hydraulic Schematic

8.3 Functional Description of Hydraulics when Operating

The description in the following chapters are relating to Figure 11 “Hydraulic Schematic”. Please use this drawing to understand the specific functionality of the ILFP lift gate.

8.3.1 Slide Out Function

- As soon as the Motor starts to run, valve S8 is energized.
- Oil pressure on input “A” sets exits “Av” and Bv” at the valve block under pressure.
- The surface at the end of the piston rod on input “B” is larger than on the shaft at input “A”.
- This creates a stronger force at the piston rod (“B”) than at the shaft (“A”).
- This factor forces the cylinder to extend.
- The lift gate will slide out to the end of the rails.

8.3.2 Lower Down

- The shift valve S5 at the pump and the solenoid release valves S1 and S2 at the cylinders will get energized. In addition the leaking down stop valve S11 in the back of the mount frame is also energized.
- The gate is designed to lower down by gravity. It will push the hydraulic oil out of the lift cylinder into the reservoir. The oil passes the solenoid release valves S1 and S2. It also has to pass the energized S11 valve in the back of the mount frame and the shift valve S5 at the pump.

8.3.3 Lift Up Function

- Motor starts running and double locking release valves S1 and S2 are energized.
- The pressure is on input “A” at the valve block. The oil passes the S11 valve and sets pressure on exit “AH”.
- The energized double locking release valves S1 and S2 forces the fluid to push the lift cylinders to extend. The platform raises up.

8.3.4 Slide In Function

- Motor starts running and S7 valve is energized.
- Oil pressure on input “A” sets pressure on exits “Av” at the valve block.
- The Oil pressure on exit “Av” at the valve block sets pressure on input “A” at the cylinder.
- The energized valve S7 is allowing the oil at the bottom of the piston rod to get back through the S5 into the reservoir.
- The pressure on the end of the shaft will force the piston rod to retract.

The liftgate will slide in under the body.

8.4 ILFP Push-Pull Valving

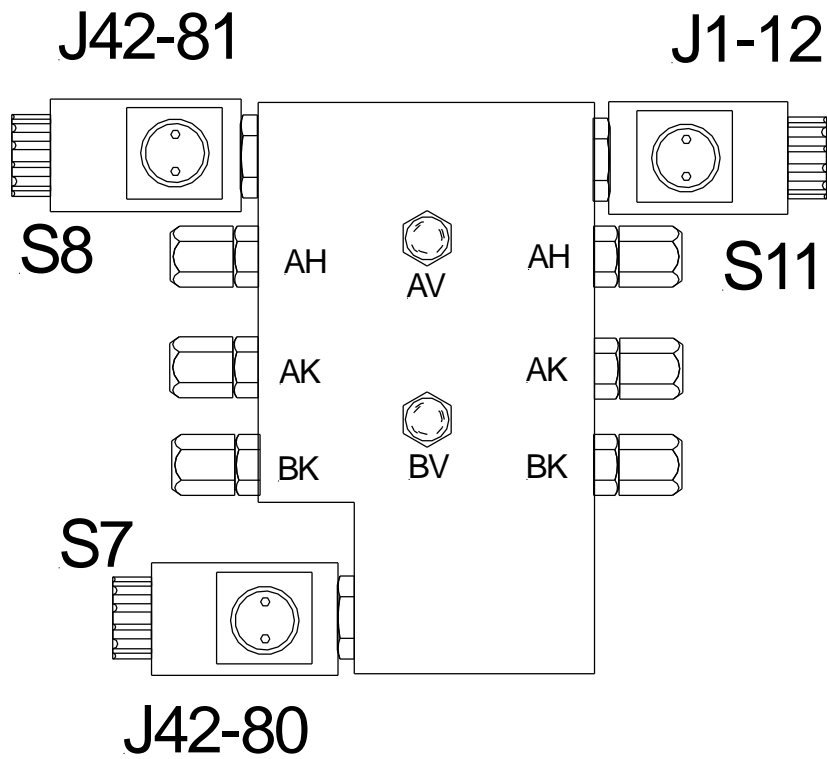

Figure 52 Valve block setup at main frame

9. Needed Information for Ordering Spare Parts and Repairs

9.1 Ordering Spare Parts

In order to assure quick delivery of spare parts, please always state the following information when making orders:

1. Liftgate model & serial number.
2. Designation and number of the spare part in accordance with the spare parts list.
3. Designation and number marked on the individual component (if available).

9.2 Repairs

Parts sent to INTERLIFT Liftgates to repair must be accompanied by a letter (in separate cover) giving details and scope of the repairs required.

10. Warranty

INTERLIFT Liftgates provides warranty as part of its conditions of delivery.

Spare part deliveries are first of all billed. INTERLIFT Liftgates then issues credit for all or part of the invoiced sum, when INTERLIFT Liftgates has been able to determine that the warranty claim is justified as defined by its warranty conditions. INTERLIFT Liftgates does this by inspecting the defected parts which are sent back to INTERLIFT Liftgates freight-prepaid as well as the written description of the problem which must have been filled out in full.

The parts that are sent back to INTERLIFT Liftgates, marked with serial number and address, become INTERLIFT Liftgates' property if the warranty claim is accepted.

All warranty claims must be received **within 30 days** of repair or replacement. Including the following information:

1. Liftgate model.
2. Liftgate serial number.
3. Description of problem.
4. Itemized bill of repair with break down of number of hours to perform warranty work and labor changes per repair.
5. Parts used for repair with INTERLIFT Liftgates part number.
6. RMA#.
7. Contact at INTERLIFT Liftgates, if applicable.

Model	Pump and Motor	Cylinders	Hardware	Control System	Hydraulic
ILFP Under Slider	2 yr	3 yr	3 yr	3 yr	2 yr

Table 3: Warranty Coverage Schedule¹

¹ Effective: Aug 2010

11. Contact Address

15939 Piuma Ave
Cerritos, CA 90703
Phone: (562)-924-8218
Fax: (562)-924-8318

E-mail (parts order):
liftgateparts@palfinger.com

E-mail (technical support):
technicalapplications@palfinger.com



572 Whitehead Road
Trenton, NJ 08619
Phone: (609)-587-4200
Fax: (609)-587-4201

E-mail (parts order):
liftgateparts@palfinger.com

E-mail (technical support):
technicalapplications@palfinger.com