

# ***INTERLIFT***

BY **PALFINGER**

---

## **OWNER'S MANUAL**

**PTF 50, 5000 lbs. Capacity**

**PTF 55, 5500 lbs. Capacity**

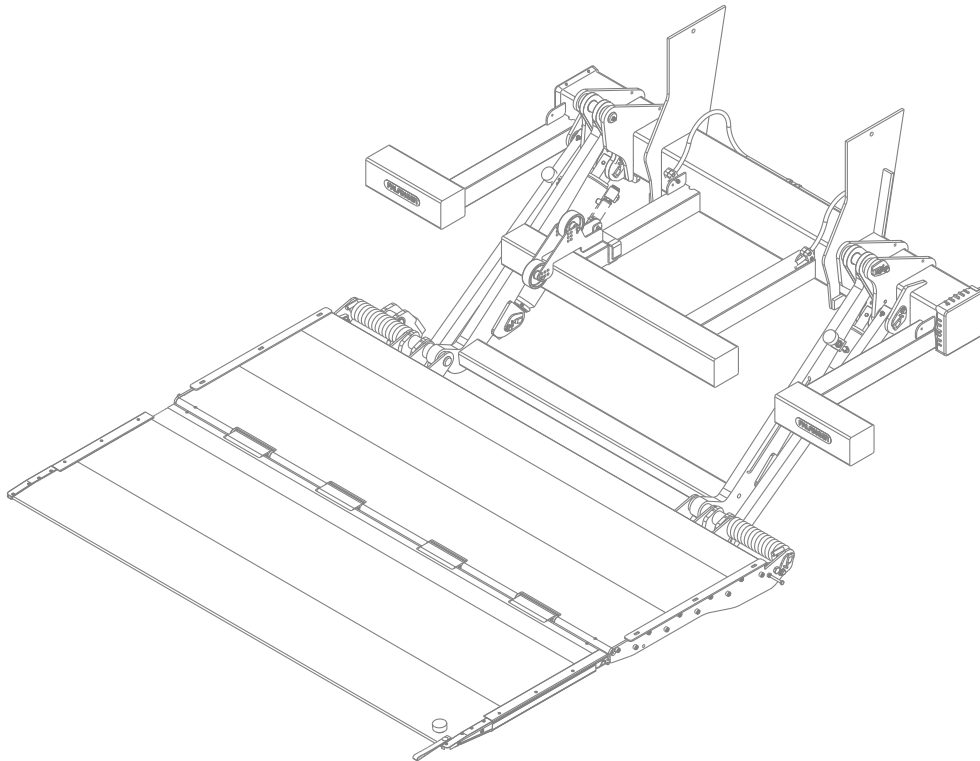

PTF 50/55 Owner 's Manual  
Document Part Number: 90-1021-101/ 21-528\_90-00\_01-01  
ECN-M1723, Rev. 1.2, 12-13-23  
Copyright © 2022 Palfinger Liftgates LLC.  
All rights reserved.

Information in this document is subject to change without notice.  
Visit [www.palfinger.com](http://www.palfinger.com) for up to date information and notifications.

If you received this product with damaged or missing parts,  
contact INTERLIFT Liftgates at (888)-774-5844

Parts Order/Inquiries  
[liftgateparts@palfinger.com](mailto:liftgateparts@palfinger.com)

Technical Support  
[technicalapplications@palfinger.com](mailto:technicalapplications@palfinger.com)



15939 Piuma Ave.  
Cerritos, CA 90703  
Tel (888) 774-5844  
Fax (562) 924-8318



572 Whitehead Road.  
Trenton, NJ 08619  
Tel (609) 587-4200  
Fax (609) 587-4201

---

## Table of Contents

<b>1</b>	<b>Manual Updates .....</b>	<b>5</b>
<b>2</b>	<b>Important Notes .....</b>	<b>6</b>
2.1	Attention.....	6
2.2	Important Notes.....	6
2.3	Improper Usage .....	7
<b>3</b>	<b>Safety Information .....</b>	<b>8</b>
<b>4</b>	<b>Important Information.....</b>	<b>9</b>
<b>5</b>	<b>General Information.....</b>	<b>11</b>
5.1	Before Operation.....	11
5.2	Liftgate Function and Usage Information.....	11
<b>6</b>	<b>General View of Liftgate .....</b>	<b>13</b>
<b>7</b>	<b>Maximum Load and Placing of Load on Platform.....</b>	<b>14</b>
<b>8</b>	<b>Operation of Liftgate.....</b>	<b>15</b>
8.1	Operation by Toggle Switch/Hand Held Remote Control .....	15
8.2	Hand Held Remote Control (Optional).....	17
<b>9</b>	<b>Platform Cart Stops (Optional).....</b>	<b>18</b>
<b>10</b>	<b>Preventive Maintenance and Quick Check.....</b>	<b>19</b>
10.1	Hydraulic Power Unit Access .....	19
10.2	Maintenance and Care .....	20
10.3	Lubrication .....	21
10.3.1	Desirable Grease Characteristics .....	22
10.4	Checking and Changing the Oil.....	22
10.4.1	Recommended Hydraulic Fluids .....	23
10.5	Decal Placement and Inspection .....	23
10.6	Quick Check List .....	26
<b>11</b>	<b>Troubleshooting.....</b>	<b>27</b>
11.1	Liftgate will not power on.....	27
11.2	Liftgate Does No Lower Down.....	29
11.3	Liftgate Does Not Lift Up .....	29
11.4	Electrical Wiring – Batteries – Truck/Trailer.....	30
11.5	Trailer to Tractor Ground Test.....	31
11.6	Wiring Diagram (Power Down).....	32
11.7	Hydraulic Schematics (Power Down) .....	33

**12    Needed Information for Ordering Spare Parts and Repairs .....34**  
    12.1    Ordering Spare Parts .....34  
    12.2    Repairs.....34  
**13    Warranty .....34**  
**14    Contact Address .....35**

**Company Information:**

**Company Name:** \_\_\_\_\_

**Advisor Name:** \_\_\_\_\_

**Trailer Year Make & Model:** \_\_\_\_\_

**Liftgate Information:**

**Liftgate Serial Number:** \_\_\_\_\_

**Liftgate Model Number:** \_\_\_\_\_

**Date of Purchase:** \_\_\_\_\_

**Date of Installation:** \_\_\_\_\_

**Thank you for choosing INTERLIFT Liftgates.**

## 1 Manual Updates

Revision	Description
v1.0	<ul style="list-style-type: none"><li data-bbox="375 367 586 396">• Initial Release</li></ul>
v1.1	<ul style="list-style-type: none"><li data-bbox="375 426 829 455">• Update Sec.11.6 Wiring Diagram</li></ul>
v1.2	<ul style="list-style-type: none"><li data-bbox="375 485 976 514">• Changed the logos, from Palfinger to Interlift</li></ul>

## 2 Important Notes

### 2.1 Attention

Before starting any operations of the liftgate, please read and understand this OWNER'S MANUAL. It is intended to act as a guide for the operation personnel as well as to give help with preventive maintenance but does not take place of unauthorized usage or repair by unqualified personnel.

Please contact your nearest INTERLIFT Liftgates distributor or INTERLIFT Liftgates in California or New Jersey for assistance if you have questions regarding installation, operation, or maintenance.

This owner's manual applies to the following models: **PTF 50/55**



This is the safety alert symbol. It is used to alert you to potential personal injury hazards. Obey all safety messages that follow this symbol to avoid possible injury.

### 2.2 Important Notes

The INTERLIFT Liftgates PTF 50/55 model is an electro-hydraulically driven liftgate, designed to be stored underneath the truck/trailer for ultimate dock loading as well as offering up to 6-1/2 feet platform.

The Hydraulic Power Unit (HPU) is easily accessible for service and exchange.

The platform folded in half is supported by two torsion springs, each on one side, one support folding the other unfolding operation. Lifting actions are carried out by hydraulic cylinders mounted on the liftarms.

The gate is equipped with swing fixtures mounted to the bottom on each lift cylinder. This enables the platform to lower down the tip towards the ground. The hydraulic cylinders are equipped with solenoid operated valves located at the port of each cylinder which prevents the platform from lowering accidentally unless the operator is activating the controls. This system also enables you to store the liftgate without a separate platform latch.

The piston rods are treated against corrosion. The HPU is equipped with a built-in pressure relief valve, which prevents overloading when lifting.



**The valves do not prevent overloading of the platform when lowering or tilting down.**



## **2.3 Improper Usage**

Some examples of improper use of the liftgate may include, but are not limited to:

- Using the liftgate as an elevating work platform.
- Using the liftgate to push, pull, or low loads or other objects.
- Using the liftgate to carry people (Only the operator may travel on the platform).
- Using the liftgate to clear snow.
- Trying to use the liftgate as a “lauching pad”.
- Using force of the hydraulic system to bend, shear, or break objects.
- Driving a forklift over the liftgate.
- Driving truck or trailer with the platform open.
- “Plowing” with the platform.

### 3 Safety Information

This manual follows the Guidelines set forth in ANSI X535.4-2007 for alerting you to possible hazards and their potential severity.



**! DANGER** indicates an imminently hazardous situation which, if not avoided, **will result** in death or serious injury.



**! WARNING** indicates a potentially hazardous situation which, if not avoided, **could result** in death or serious injury.



**! CAUTION** indicates a potentially hazardous situation which, if not avoided, **may result** in minor or moderate injury.



**CAUTION** without the safety alert symbol is used to address practices not related to personal injury.

*(In this manual we use it to alert you to potentially hazardous situation which, if not avoided, may result in property damage.)*



**NOTICE** without the safety alert symbol is used to address practices not related to personal injury. *(In this manual we use it to alert you to special instructions, steps, or procedures.)*



Improper operation of this liftgate may result in severe personal injury or death. **DO NOT** operate unless you have been properly instructed, have read and are familiar with the procedures in this manual. We have designed this manual to illustrate the steps needed for the basic operation of this PTF liftgate. It also provides safety information and simple preventive maintenance tips.



## 4 Important Information

### Before Getting Started

## “READ FIRST”

### NOTICE

Before starting any operations of the liftgate, please read and understand this Owner's Manual. The intention of this manual is to provide the user a guide for the operation as well as preventive maintenance. Do not attempt to modify or repair the liftgate unless performed by qualified personnel. Please contact your nearest INTERLIFT Liftgates distributor or INTERLIFT Liftgates in California or New Jersey for assistance if you have any questions regarding installation, operation or maintenance at 888-774-5844.

This owner's manual applies to the following models: **PTF 50/55**

#### Important notes

The electric supply is taken from the vehicle battery. If the vehicle battery is not sufficient, an auxiliary battery kit needs to be installed. The electric control power is secured via a 15-Amp fuse and an on-off switch located inside the cab.

Trailer applications have an on/off switch near the rear curb side corner post.

The liftgate is operated from a standard toggle switch. A hand held remote control is optional with up and down functions. A variety of different control options can be purchased with the INTERLIFT Liftgates product.



The valves do not prevent overloading of the platform when lowering or tilting down.

### WARNING

Improper operation of this liftgate may result in severe personal injury or death. **DO NOT** operate unless you have been properly instructed, have read and are familiar with the procedures in this manual. This manual has been designed to illustrate the steps needed for the basic operation of the PTF liftgate. It also provides safety information and simple preventive maintenance tips.

### NOTICE

This manual is not intended for use as a repair or troubleshooting guide. Repairs should be performed by an INTERLIFT Liftgates Authorized Service Center.

This Manual has been designed for use in conjunction with the PTF series liftgates only which are designed for different capacities. There are four options available to determine the model and serial number of the installed liftgate:

There are four options available to determine the model and serial number of the installed liftgate:

- 1) Refer to the serial number tag on top of the mount tube at curb side as shown in **Fig. 1**.

### Serial Number Tags

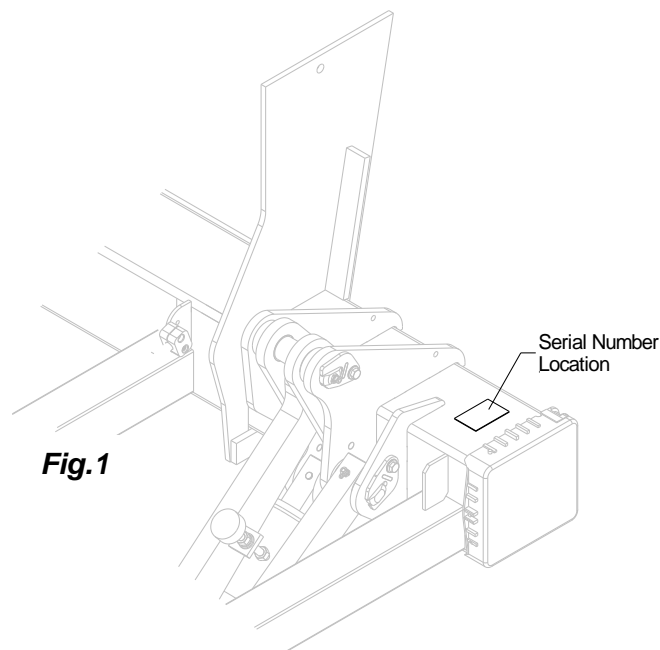
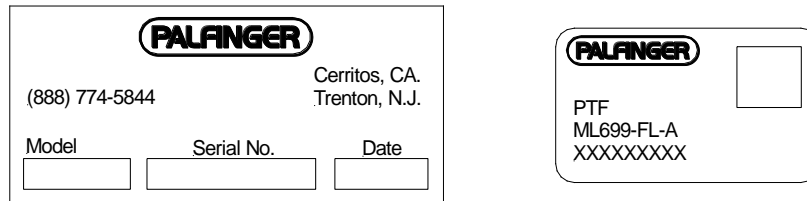

**Fig.1**

- 2) Ask your employer or lessor.
- 3) Call your INTERLIFT Liftgates Authorized Service Center for assistance.
- 4) Call INTERLIFT Liftgates for assistance in the USA at 888-774-5844. You can also contact INTERLIFT Liftgates by fax (562) 924-8318 or on the internet- [www.palfinger.com](http://www.palfinger.com)

For technical support, contact INTERLIFT Liftgates or an authorized INTERLIFT service center. [www.palfinger.com](http://www.palfinger.com)

## 5 General Information

### 5.1 Before Operation

#### REMEMBER:

It is the fleet manager's responsibility to educate the operator on the liftgate and its intended use. The operator's attention should be drawn to the permitted load limits and an understanding of the operation to ensure the safety throughout the operation.

#### ONE-MAN OPERATION:

Never let an "outsider" operate the liftgate while you are handling the cargo.

A "misunderstanding" can result in serious personal injury.

In the interest of safety, it is important that all operating personnel properly understand the functions of the liftgate, possible hazards, dangers, the load limits and load positioning for that specific unit.

### 5.2 Liftgate Function and Usage Information



Before the operator uses the liftgate, they should be thoroughly familiar with the liftgate functions and usage according to the following:

1. Improper operation of this lift can result in serious personal injury. Do not operate unless you have been properly instructed, have read and are familiar with the operation instructions. If you do not have a copy of the instructions please obtain them from your employer, distributor, or lessor as appropriate before you attempt to operate the lift.
2. Be certain the vehicle is properly and securely stopped before using the liftgate.
3. Always inspect this lift for maintenance or damage before using it. If there are signs of improper maintenance, damage to vital parts or slippery platform surface, do not use the lift. Do not attempt your own repairs unless you are specifically trained.
4. Do not overload. See the Rating Label on the unit for the rated load. Remember that this limit applies to both raising and lowering operations.
5. Each load should be placed in a stable position as near as possible to the body of the truck/trailer.
6. Never stand in, move through or allow anyone else to stand in or move through the area in which the lift operates, including that area in which a load might fall.
7. This liftgate is intended for loading and unloading of cargo only. **DO NOT** use this Liftgate for anything but its intended use. This is not a passenger lift. Do not ride the lift with unstable loads or in such a manner that a failure would endanger you. The lift is not equipped with a back-up system to prevent falling cargo in the event of a failure.



**The maximum loads must be observed and followed!**

**Please read through the operational and technical description of the INTERLIFT Liftgate.**

**Thank you for choosing INTERLIFT Liftgates.**

# 6 General View of Liftgate

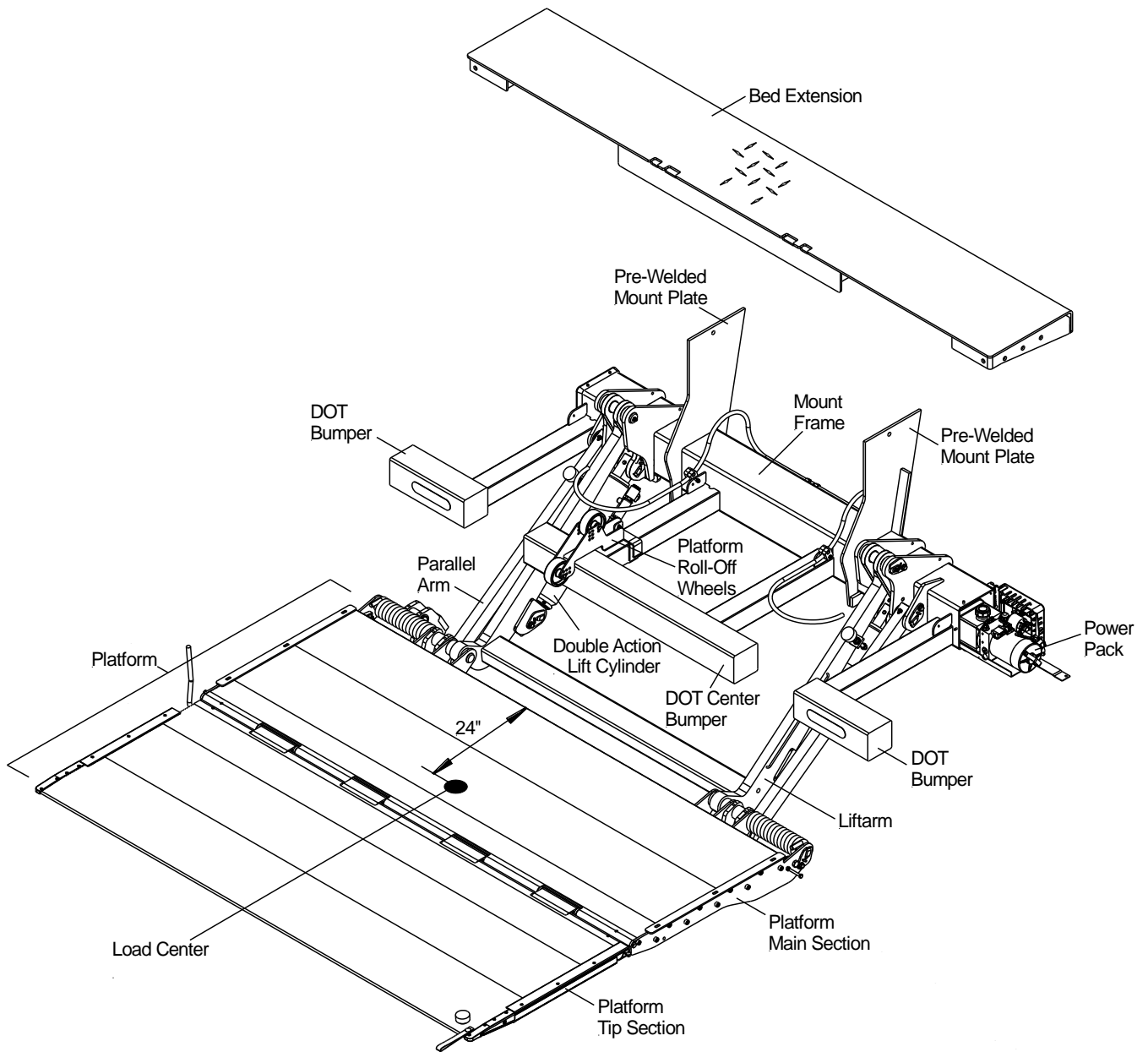

## 7 Maximum Load and Placing of Load on Platform

Every INTERLIFT liftgate is rated up to a maximum load. The point of maximum load is rated at a defined distance. The center point of maximum load is at 24" from the rear of the bed extension out to the platform, **Fig.2.**

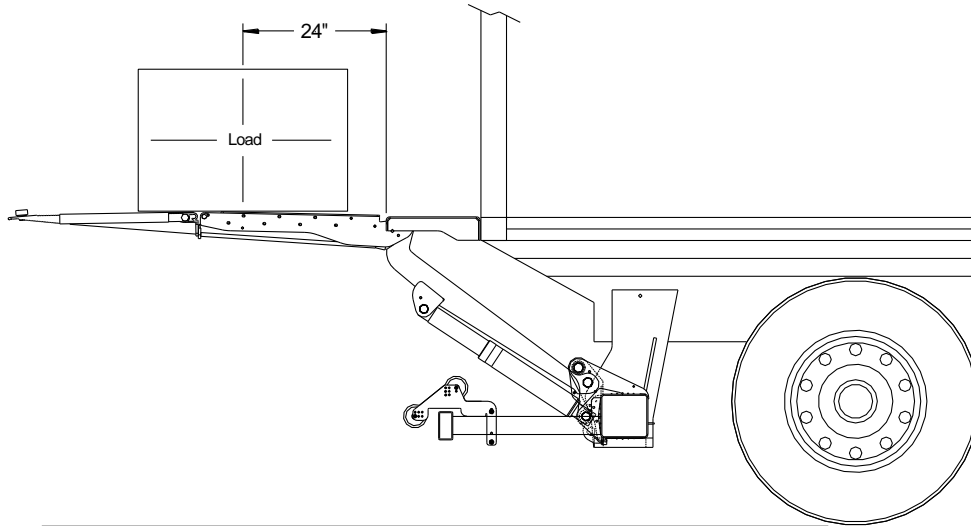
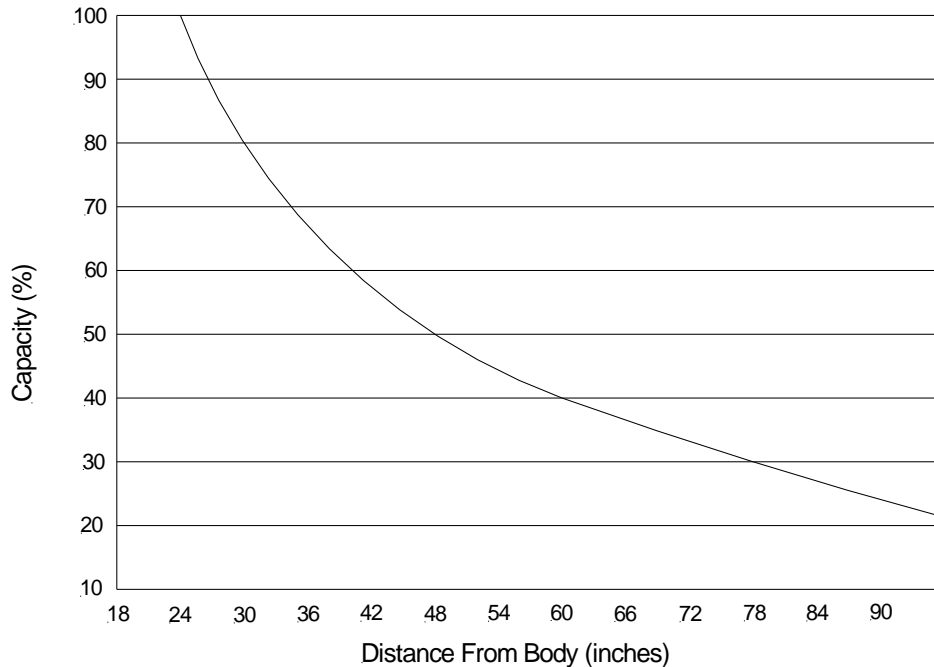

**Fig.2.**



By increasing this distance, the maximum load of the liftgate is decreasing.

An overview about the rating depending on the distance from the end of the platform is shown in the following load diagram.



## 8 Operation of Liftgate

### 8.1 Operation by Toggle Switch/Hand Held Remote Control

#### To Open Liftgate

1. Power on the liftgate by switching the ON/OFF switch ON. ON/OFF switch location for a truck is located in the cab, **Fig.3**, for a trailer it will be located on the dock bumper strut, **Fig.4**.

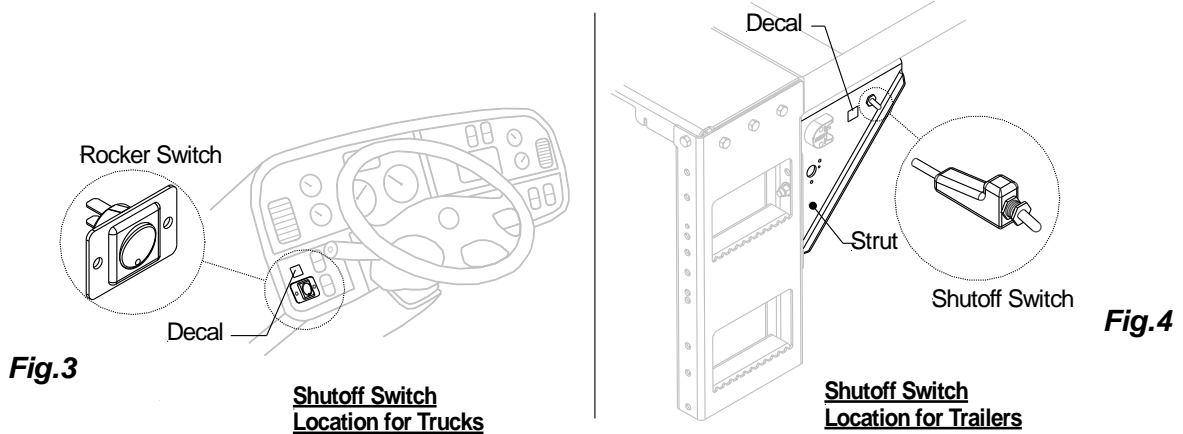

2. Use the **Down** function of the toggle switch to lower the gate from the stored position, **Fig.5**, until the platform rest on the wheel, **Fig.6**.

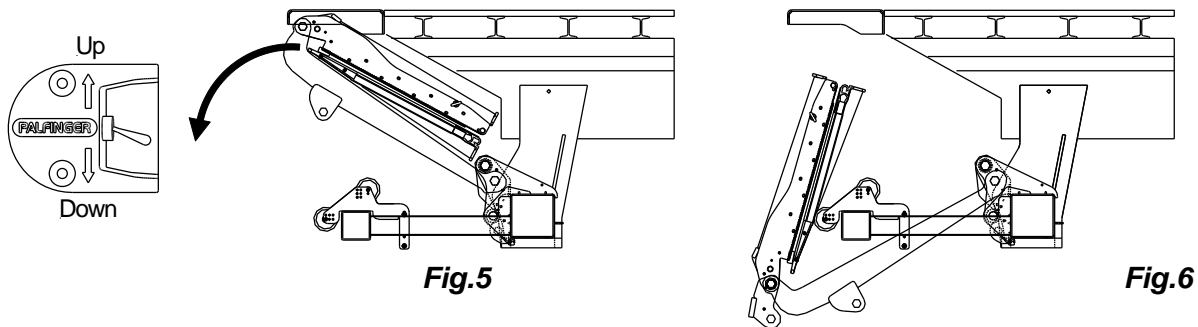

3. Steel and aluminum platform tips have a safety strap installed that secure the tip to main, **Fig.7**. The strap is used to manually fold and unfold the platform tip before and after operating the liftgate.

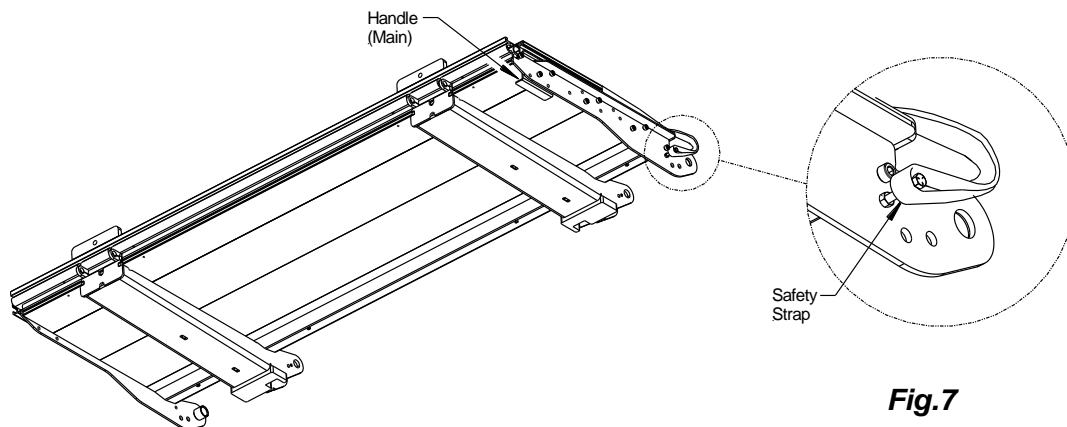

- Use the handle on the main section to manually pull the platform away from the wheels down to the ground, **Fig.8**. Unhook the strap on the side of the platform and use the strap to open the tip manually, **Fig.9**.

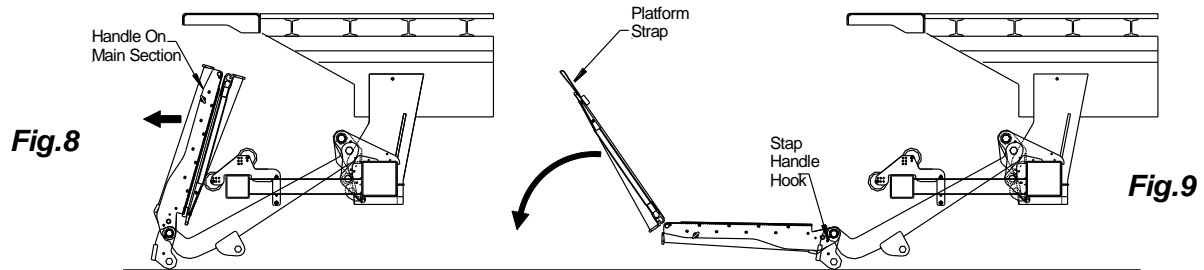

- Center the load on the platform 24" away from the rear of the bed extension, **Fig.10**. Use the toggle switch to lift the platform/load up and down, **Fig.11**.

**NOTE: The 2-Button Hand Held Remote may also be used in this step, if option is installed.**

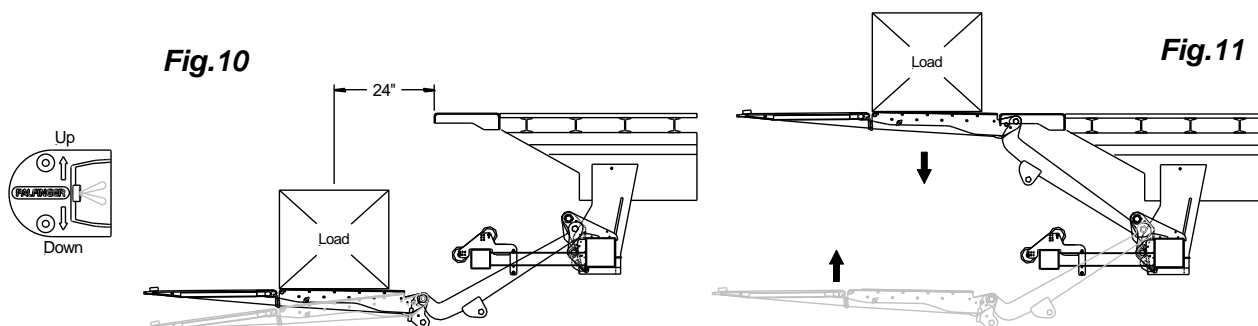

### To Store Liftgate

- Raise platform approximately 16" from the ground, fold the tip manually using the strap, **Fig.12**. Secure the tip to the main by hooking the strap to the side of platform. Manually lift the platform to rest against the wheels, **Fig.13**.

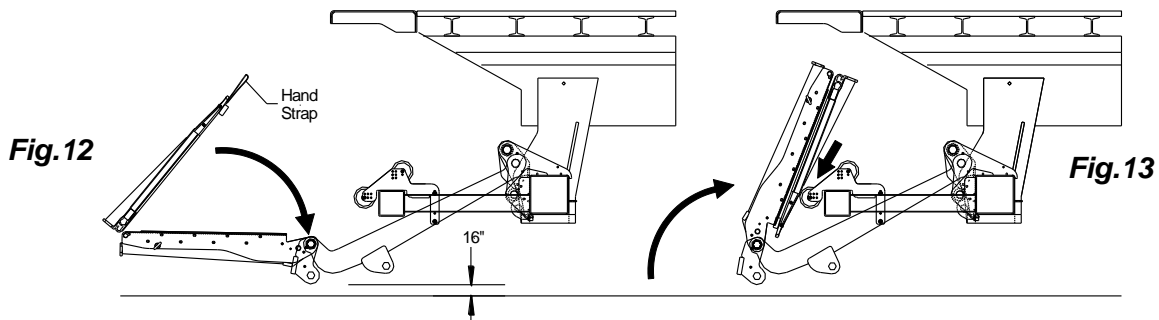

- Use the **UP** function on the toggle switch to raise the platform to stored position, **Fig.14**.

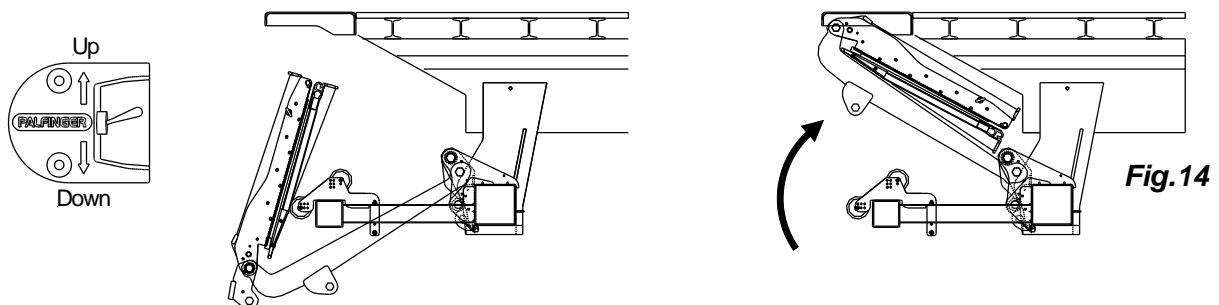

- Turn the ON/OFF switch **OFF** when liftgate is not in use.



## 8.2 Hand Held Remote Control (Optional)

### 1. Lowering Down

Press and hold the DOWN button to lower platform.

#### Tilt Down (at Ground Level)

Continue holding the DOWN button until the platform starts tilting down automatically to ground.

### 2. Lifting Up

Press and hold the UP button to raise platform from the ground.

#### Tilt Up (at Ground Level)

Continue holding the UP button until the platform starts to raise up from the tilt position. Continue raising the platform up to bed level.

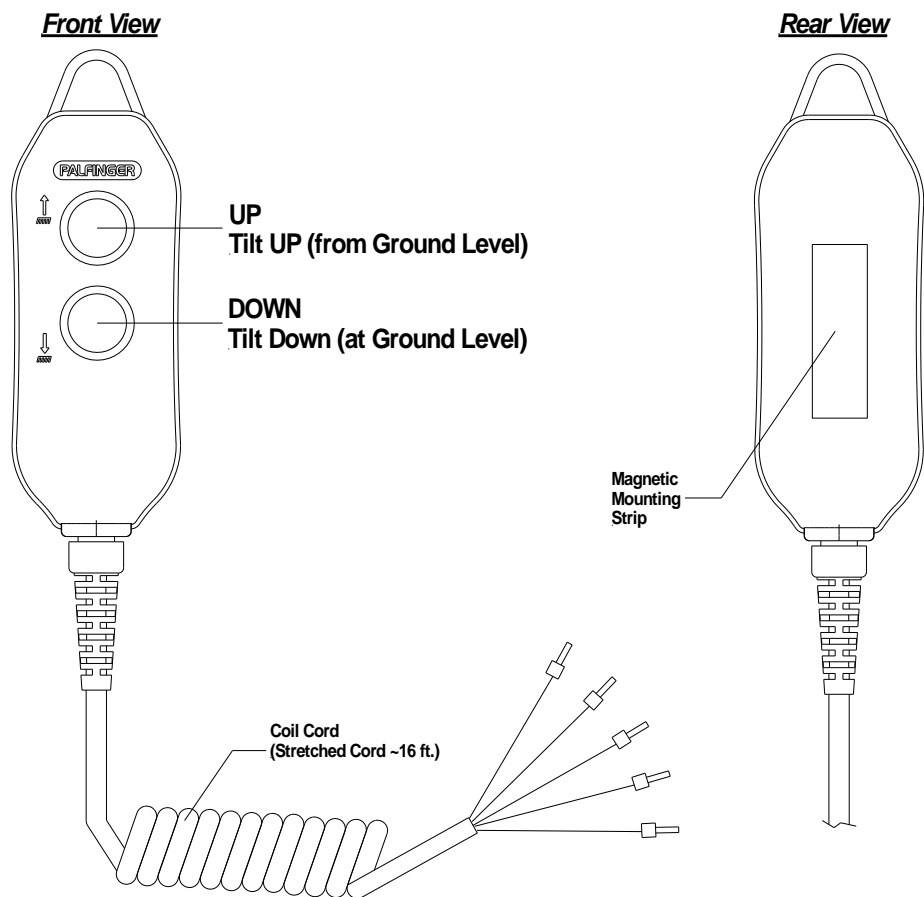

**Reminder: Do not store remote inside refrigerated vehicles. Control will be damaged.**

## 9 Platform Cart Stops (Optional)

1. Push the cart stop latch out toward the curb side, **Fig.15**. The cart stop will spring open automatically once the latch has been moved from its original position, **Fig.16**.
2. To close the cart stops, push the cart stop latch inward towards the street side, **Fig.17**. After the latch is in place close each cart stop by pushing each stop.

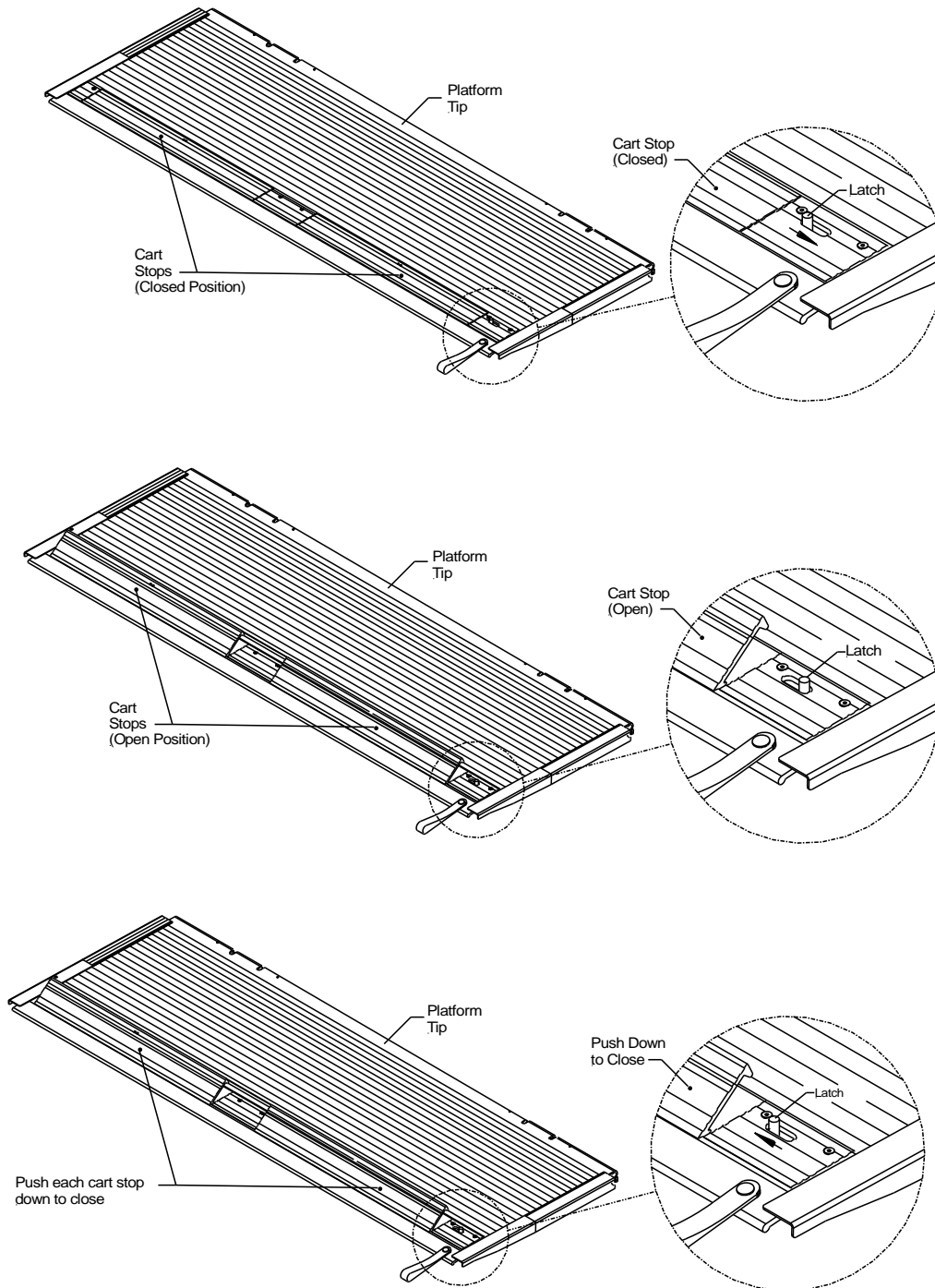

**Note: One latch is used to open both cart stops.**

## 10 Preventive Maintenance and Quick Check

The PTF liftgate needs preventive maintenance to perform at its fullest capability. Lubricate and inspect regularly. Also, check on hoses, cables, controls, etc. and make sure these components are not damaged.



**REPAIR OR REPLACE FAULTY PARTS IMMEDIATELY**



### 10.1 Hydraulic Power Unit Access

To access the Hydraulic Power Unit, open the cover on the curb side of the mount tube. Remove the nut and bolt securing the hydraulic power unit to the mount tube. Pull the hydraulic power unit out approximately 14-16" to access the solenoid, oil reservoir, cables, valves, etc.

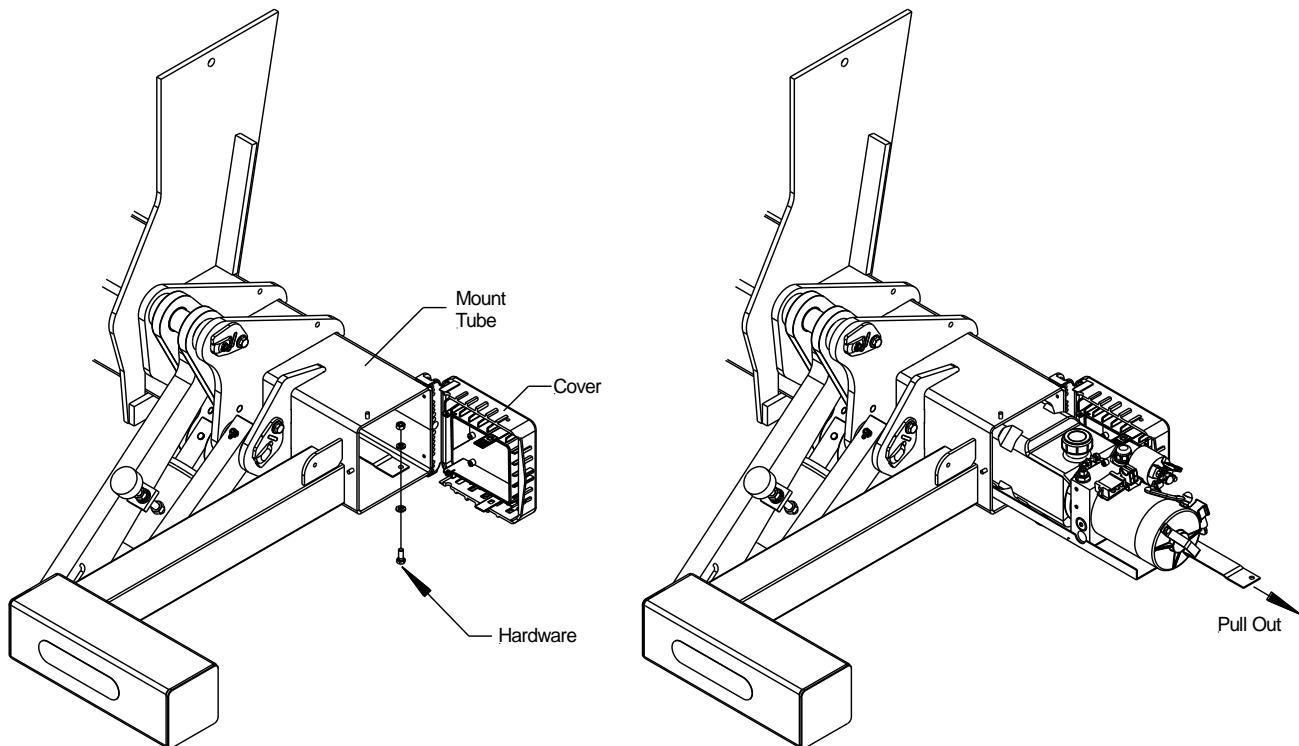

## 10.2 Maintenance and Care

The following "inspection and maintenance" should be performed at the recommended intervals depending on operation and amount of cycles or at the time when the unit shows any signs of damage or abuse. In order to prolong the liftgates longevity it is important to maintain and perform preventive care as indicated below. Follow chapters 10.3 and 10.4 for details.

* Recommended bases for inspection and maintenance	Depending on use	Daily	Monthly	Quarterly
Cleaning	x			
General lubrication of pins and bushings				x
Oil level inspection				x
Oil change	x			
Check hydraulic hoses and pipes for leaks				x
Check controls and connections				x
Check pins and pin retaining bolts			x	
Check batteries and connections				x
Check warning labels and other safety equipment for effectiveness and visibility		x		
Visual check for loose or missing parts and un-usual noise during operation		x		
Check lock bolts and pins for tightness				x
Check complete function of gate		x		
Check mounting brackets of lift gate to frame for cracks or damage visually		x		

Maintenance Schedule

### 10.3 Lubrication

Properly lubricated, the PTF series INTERLIFT Liftgates will ensure longevity. Lubricate the liftgate at the same time as the truck/trailer. Grease more frequently if the liftgate is heavily used. The liftgate should be greased every 500 cycles (depending on use – estimated every 3 month).

**All bearing points must be lubricated in accordance with the maintenance intervals.**

*Reminder: Lubricate all points with the platform at ground level.*

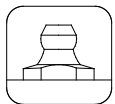
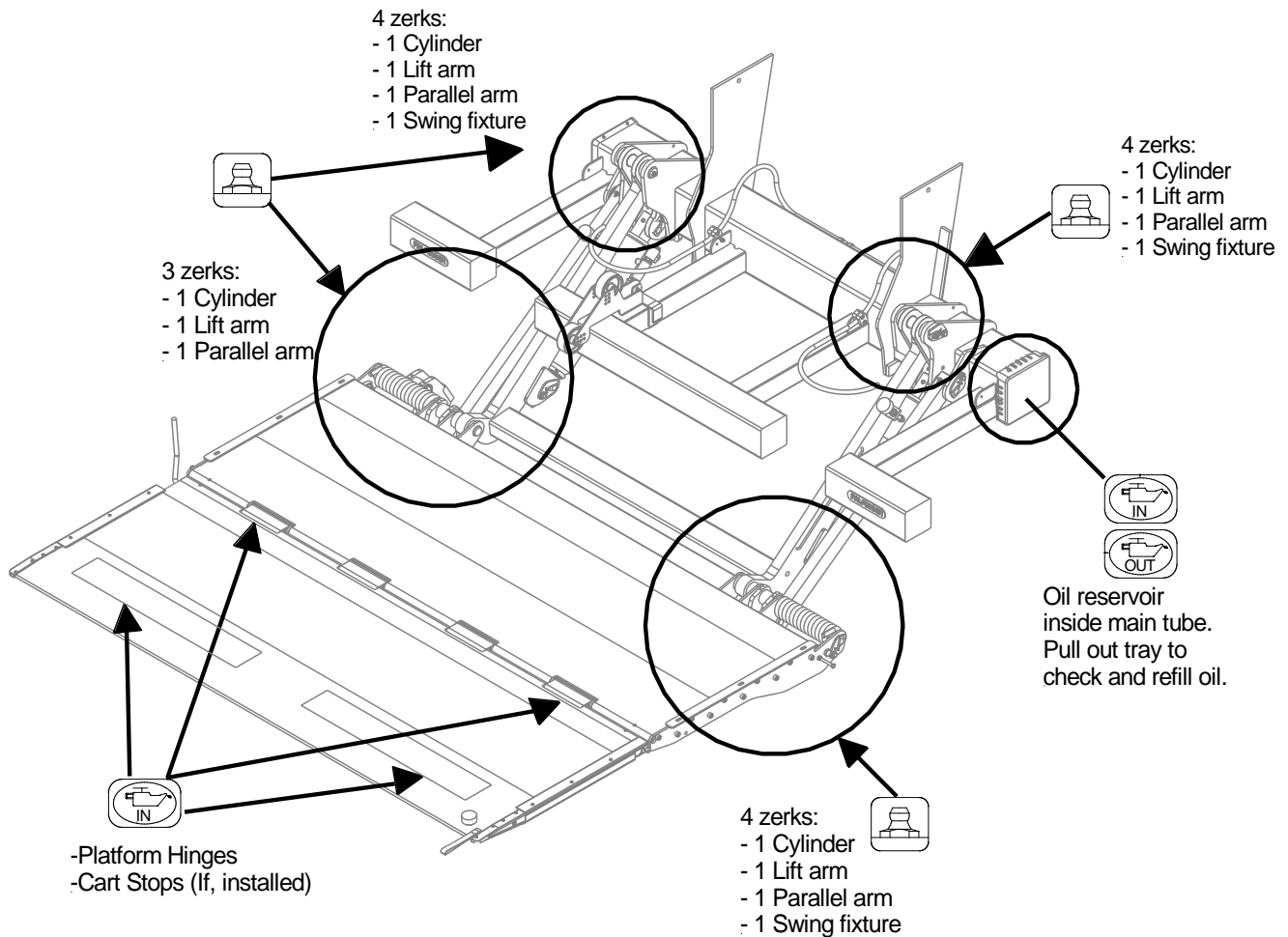

**Grease:** Location of Grease Zerks (7 on each side, 14 total)

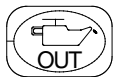
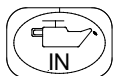

**Oil:** Oil level in the power pack tank (see marking inside of power pack reservoir)

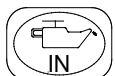

**Lubricate:** Platform hinges, Slide Rails and optional Cart Stops (use WD-40 spray for lubrication)

### 10.3.1 Desirable Grease Characteristics

Desirable Grease Characteristics		
Typical Properties	ASTM Method	Values
NLGI		2
Thickener Type		Polyurea, Calcium Sulfonate, Lithium Complex
Color		Various
Molybdenum Disulfide, %		5
Low Operating Temperature, °F		-40
High Operating Temperature, °F		250
Base Oil Viscosity 40°C, cst	D445	150 - 220
Dropping point, °C	D2265	260 +
Ball wear, scar diameter, mm	D2266	0.45
Ball weld load, kg	D2596	500 +
Rust Prevention	D1743	Pass
Copper Corrosion	D4048	1A
Water Wash-Out, 79°C, Mass %	D1264	< 1

Example : Chevron NLGI 2 Black Pearl Grease EP

### 10.4 Checking and Changing the Oil

**To check fluid:**

1. To begin, lower gate to ground and tilt platform down.
2. Open the rubber cover on the curb side of the mount tube and remove the lock bolt on the power pack tray. Pull the power pack tray out until the oil filler cap can be accessed.
3. The level of the oil should be no more than 1” from the top of the oil reservoir when the platform is tilted down at ground level. If fluid is required, use a recommended fluid from Section 10.4.1.

**To change fluid:**

4. Unscrew the oil drainage bolt and let the fluid drain out of the reservoir into an approved container. When reservoir is empty fill the reservoir up to within 1” from the top of the reservoir. Change oil at least once a year, preferable in the fall before the weather gets cold. The operation of the liftgate will accumulate condensation and some dirt which can interfere with the liftgates performance.

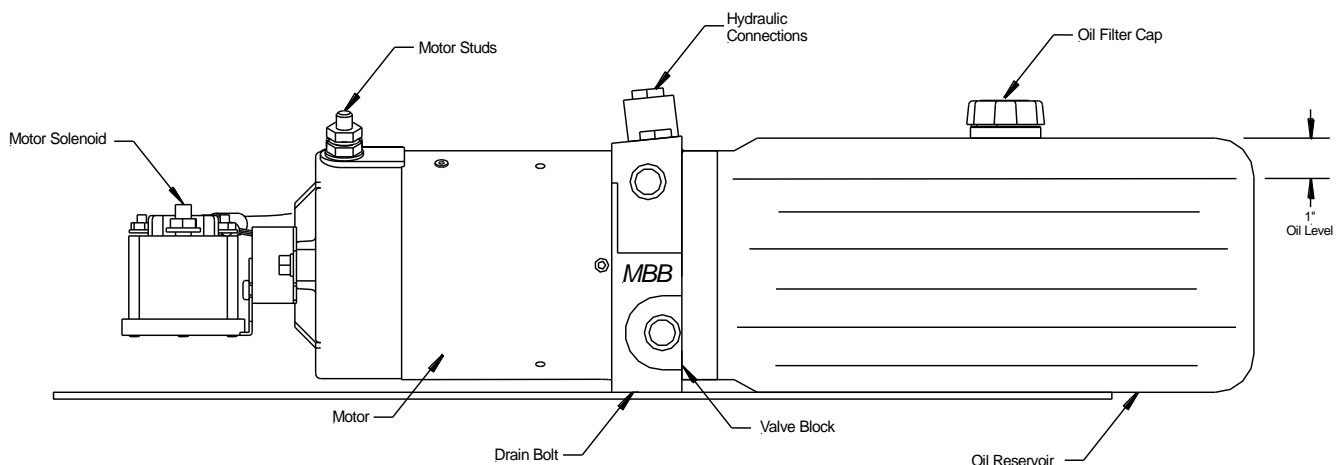

### 10.4.1 Recommended Hydraulic Fluids

Alternative Fluids	
Temperature Range	Fluid Brand
30° to 150° F	EXXON UNIVIS J26
	MOBIL DTE 13M
	CHEVRON AW MV32
	ROSEMEAD MV 150 (32)
-50° to 150° F	MOBILE DTE 11
	SHELL AERO FLUID 4/41
	SHELL TELLUS 15
Extreme Cold Temperature	MIL H5606 (Military Spec.)

### 10.5 Decal Placement and Inspection



For operator's safety, all decals appearing in the "Decal Kit" must be placed visibly on control side of liftgate to be read by operator. This is typically a combination of decals on the liftgate and truck/trailer body. Please make sure to place the maximum capacity decal (D) on driver and curb side.

Decal Kit			
Decal	Qty.	Part No.	Description
A	1	ATG-URGWA	Urgent Warning: Elevating Gate Instructions
B	1	ATG-ILR-ILFS	Operating Instructions
C	1	ATG-BKR	Circuit Breaker Reset (must be located at the circuit breaker)
D	2	ATG-XXXX	Capacity (check the serial number plate to find out the gates specific capacity)
E	1	ATG-RESET	Circuit Breaker Protection
F	2	ATG-WLH	Warning: Liftgate Can Crush
G	2	ATG-PLAT	Caution: Always stand clear of platform area
H	1	ATG-UD	Toggle Switch Decal
J	1	ATG-CAB	Liftgate Shut-Off (Place Decal next to the On-Off Switch in the Cab)
K	1	ATG-WNG	Warning: Use Handle to Open (must be located underneath handle (main section))
L	1	ATG-ILTLUB	Lubrication and Fluid Points
M	Roll	85-1114-003	Conspicuity Tape
N	1	85-0315-100	Palfinger Logo, 1.81" x 8.375"
O	1	ML2032626	Palfinger Logo 3" x 38"

# NOTICE

It is the installer's responsibility to determine the proper application of the Conspicuity tape, and to ensure that the vehicle meets DOT and federal lighting regulations. Keep in mind that there are different requirements depending on the classification of the vehicle. Placement of decal "M" shown below is an example of conspicuity tape placement. This document is not intended to replace published agency regulations, and it is strongly recommended that the installer references the Code of Federal Regulations (CFR) which can be viewed at <http://ECFR.gpoaccess.gov>.

**Decal - A**

**URGENT WARNING**

**BEFORE OPERATING LIFT, BE SURE YOU UNDERSTAND:**

1. Improper operation of this lift gate can result in serious personal injury. Do not operate unless you have been properly instructed, have read, and are familiar with, the operating instructions. If you do not have a copy of the instructions please obtain them from your employer, distributor or lesser, as appropriate, before you attempt to operate the lift gate.
2. Be certain the vehicle is properly and securely braked before using the liftgate.
3. Always inspect this lift gate for maintenance or damage before using it. If there are signs of improper maintenance, damage to vital part, or a slippery platform surface, do not use the lift gate. Do not attempt your own repairs, unless you are specifically trained.
4. Do not overload. See the Mfg. Literature and/or Rating Label on the unit for the rated load. Remember that this limit applies to both raising and lowering operations.
5. Each load should be placed in a stable position as near as possible to the center of the platform.
6. Never allow yourself, a helper, or a bystander to stand in a position where an unstable load might fall on them. Do not allow any part of your or your helper's body to be placed under, through, or around any portion of the moving lift gate, or in a position that would trap them between any parts when the lift gate is operated.
7. This lift gate is intended for loading and unloading of cargo only. Do not use this lift gate for anything but its intended use. This lift gate is not equipped with a back up system to prevent falling in the event of a failure.

ATG-MORWAL

**Decal - C**

**NOTICE**

**ELECTRICAL SYSTEM PROTECTED BY RESETTABLE CIRCUIT BREAKER**

**TO RESET - PUSH RESET TAB IN**

ATG-BKH

**Decal - D**

⚠ **CAUTION**

**MAXIMUM LOAD CAPACITY**

XXXX LBS

[XXXX KG]

**CENTER LOAD ON PLATFORM TO AVOID PERSONAL OR PROPERTY DAMAGE**

**Decal - E**

**NOTICE**

**ELECTRICAL SYSTEM IS PROTECTED BY A RESETTABLE CIRCUIT BREAKER. SEE OWNER'S MANUAL AND DECAL LOCATED AT THE BATTERY.**

ATG-RESET

**Decal - B**

**NOTICE**

The system is not an OSHA regulated lift. Follow up with a dealer. See #1 to #6.

**To always use safety lift gate:**

- Do not use platform to lift
- Do not use platform to lift
- Release the platform

1. Platform level

2. Platform tilted

3. Platform tilted

4. Platform tilted

ATG-MORWAL

**Decal - F**

**WARNING**

**LIFTGATE HAZARDS CAN RESULT IN CRUSHING OR FALLING**

**KEEP HANDS AND FEET CLEAR OF PINCH POINTS**

**IF RIDING LIFTGATE, MAKE SURE LOAD IS STABLE AND FOOTING IS SOLID**

READ AND UNDERSTAND ALL INSTRUCTIONS AND WARNINGS BEFORE USE. ATG-MOR

**Decal - G**

**WARNING**

**ALWAYS STAND CLEAR OF PLATFORM AREA**

ATG-MOR

**Decal - H**

**NOTICE**

UP
   
 DOWN

ATG-UD

**Decal - J**

**NOTICE**

**LIFT GATE SHUT-OFF**

**TO BE TURNED OFF WHEN LIFT IS NOT IN USE**

ATG-CAR

**Decal - K**

**WARNING**

**USE HANDLE TO OPEN ALWAYS STAND CLEAR OF PLATFORM AREA WHEN OPERATING THIS GATE**

ATG-MOR

**Decal - L**

**NOTICE**

**NEZZI PALFINGER**

1500 kg (3300 lbs)

1.7 m (5'7")

1500 kg (3300 lbs)

1.7 m (5'7")

EXTREME TEMPERATURES

Maximum Fork Capacity

1500 kg (3300 lbs)

USE SAFETY SPEED

10% MAX

ATG-MOR

**Decal - M**

PALFINGER

**Decal - N**

**Decal - O**

PALFINGER



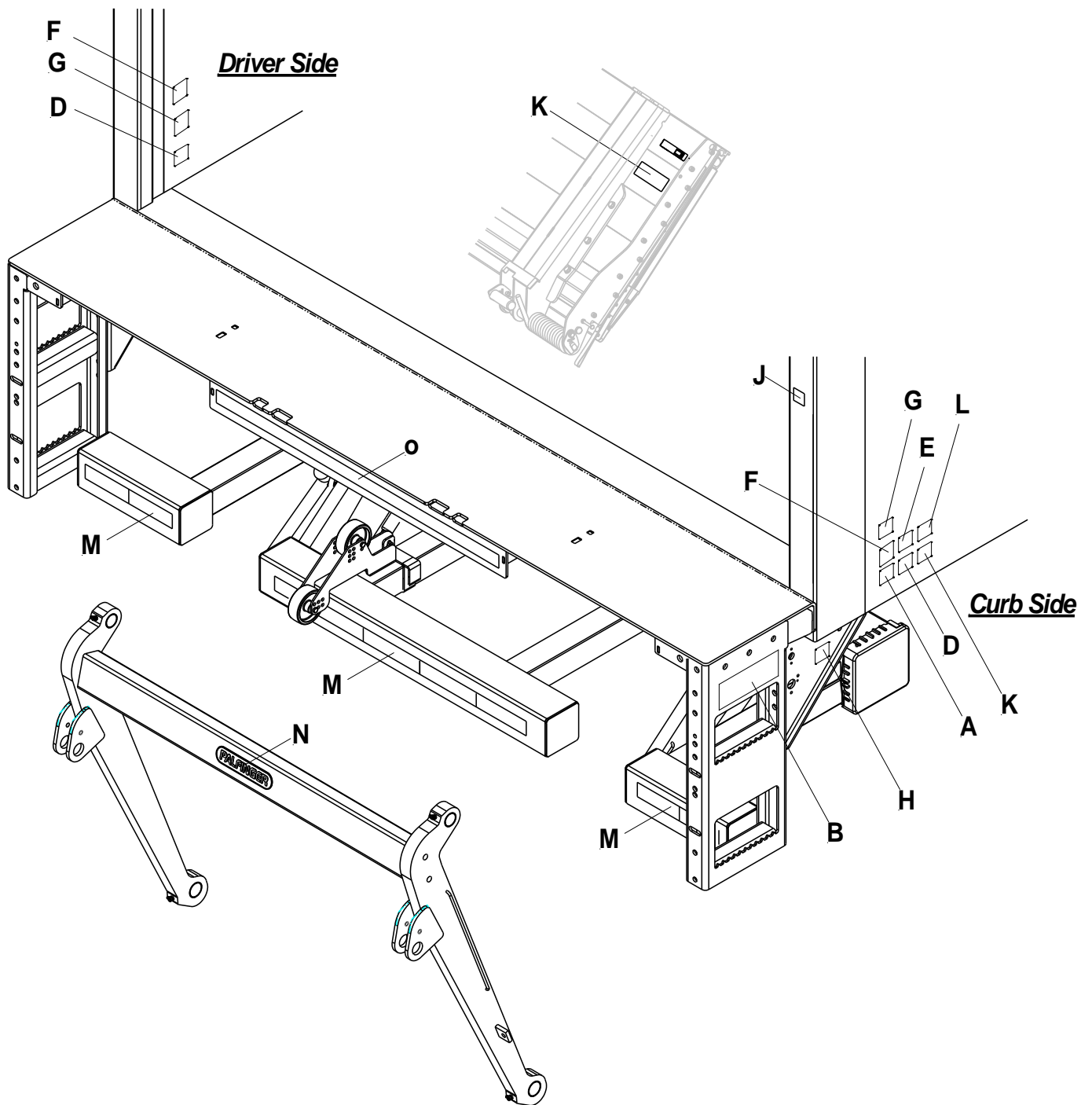

## 10.6 Quick Check List

1. Operate the lift gate throughout its entire operation and check for noise and damage such as bent parts or cracked welds.
2. Inspect all welds and fasteners that attach the mount frame to the truck. All pins and bolts that connect the lift arm to the mount frame and to the platform.
3. Visually inspect the hydraulic lines for damage, scratches, bending or leakage.
4. Inspect the cylinders for leakage and that the cylinder pins are secured with lock bolts.
5. Check the oil level when the platform is down at ground level. The level should fall between the upper markings 5 and 7 on the tank (about  $\frac{3}{4}$  of the tank). We recommend replacing oil after the first 1200 cycles, after that on a yearly basis in the fall before winter begins.
6. Check for oil leakage around the power pack and inside mount tube. Tighten or replace components if needed. If you perform work on any hydraulic components bleed the air out of the system by operating all functions several times.
7. Check all electrical connections. Clean and protect battery terminals and check for tightness.
8. Inspect all the terminals on the solenoid-operated valves at the port of the cylinder. Lubricate the terminals for better protection from oxidation if needed.
9. Grease all zerks on the lift gate and make sure they all take grease. Sometimes it helps to operate the lift gate while you do this.
10. Test all the lift gate functions.
11. Check the function of the pressure relief valve.
12. When doing daily checks and you find any kind of damage that can make the use of the liftgate dangerous, it must be repaired before using. All repairs should be made by an authorized technician. Use only original spare parts. If in doubt, contact your INTERLIFT Liftgates distributor or call INTERLIFT Liftgates directly.



**Do not cover up any accidents or damage; it can be dangerous for you and your co-workers.**

## 11 Troubleshooting

### ATTENTION:



**Please check the following points before identifying any faults.**



Serious injuries are possible from tools short circuiting main battery connections. Do not leave tools or other equipment that may cause shorts around the battery.

- Please change oil after working on hydraulic unit (removal of valves, opening of cylinder etc.)
- There is a possibility of injury if somebody other than an authorized technician works on the liftgate.
- Injuries are possible if short circuits are caused by tools, jewelry, or other conductive objects on or near the battery connections.

### 11.1 Liftgate will not power on

#### 1. Check the shut off switch.

Turn ON the ON/OFF switch located inside the vehicles cab (Truck) or on the dock bumper strut (Trailer).

#### 2. Check the circuit breaker at the main batteries.

Every truck has a circuit breaker on top of the main batteries or if you have an auxiliary battery kit as shown in the illustration below.

If circuit breaker reset tab is exposed, push it back in as shown on the decal ATG-BKR next to the circuit breaker or on battery box lid.

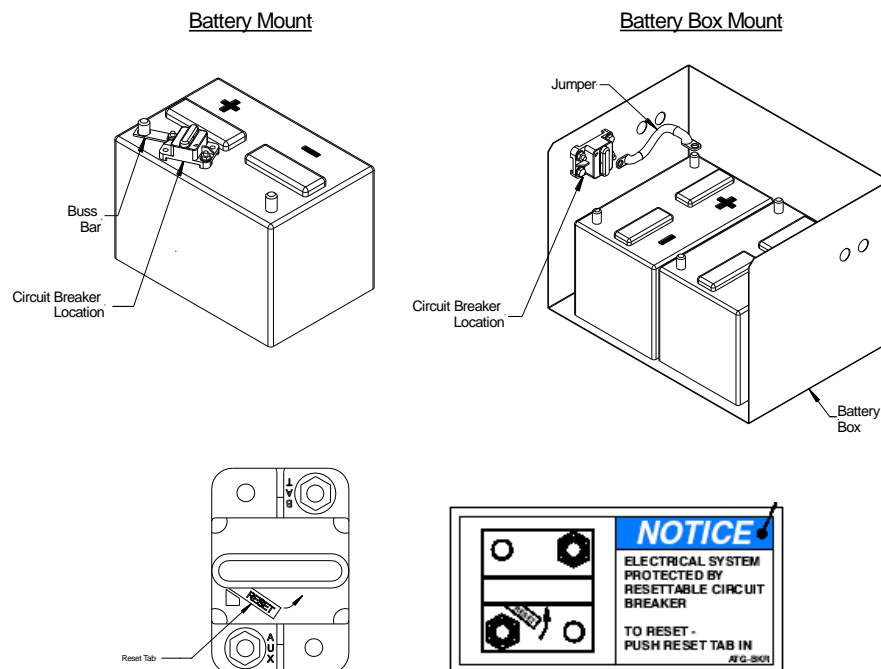

*Circuit Breaker Needs to be Reset when Reset tab is exposed*

### 3. Are the vehicle batteries charged?

Check batteries and the truck/trailer charging system. Start truck and run engine in fast idle for charging the batteries. If liftgate starts working, recharge and load test batteries. Measure battery voltages: Flooded Batteries = 12.6V; AGM Batteries = 12.8V

### 4. Check the fuse(s) at the power pack unit.

On the curb side of the mount frame, inside the tube, the power pack unit has a 15A fuse attached to the solenoid. Check for burned fuse and replace with the same amperage fuse if necessary.



**DO NOT use higher amperage fuse.**

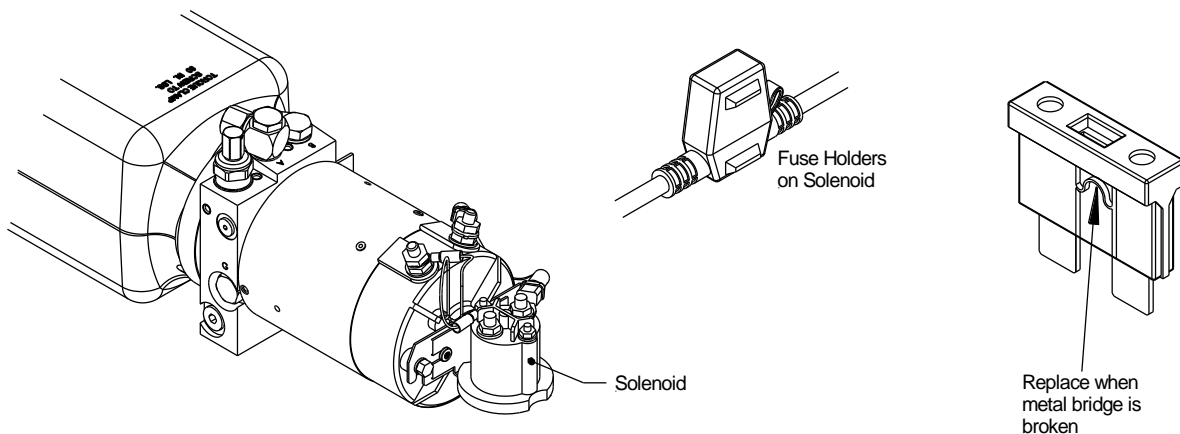

In-Line ATC Fuse 15 Amp at solenoid. Replace with same amperage fuse when necessary.  
**NOTICE: DO NOT attempt to jump in-line fuse(s) with other objects other than the specified fuse(s). DO NOT increase the amperage rating of fuse. Serious harm to the liftgate will result when standard practices are not followed.**

### 5. Is the connection to ground on power pack unit OK?

Is the ground connection from the liftgate to vehicle properly grounded?

### 6. Check the oil level in the Power Unit.

The power unit is located inside the mount tube. To access the oil reservoir, remove the screw and slide out the power pack until there's access to the oil reservoir. The oil level must be 1.0"-1.5" down from the top of the reservoir.

### 7. Are there any damages on mechanical or electrical parts (such as damaged cables)?

Perform a visual inspection of all electrical wiring and mechanical components.

## 11.2 Liftgate Does Not Lower Down

1. Visually check the valves at cylinders for mechanical damage such as bent or broken valves.
2. Open up the lid at the power pack unit and unplug the black cable (#2) with the inline fuse.
3. Unplug cable #6 from toggle switch to both wire release valve harnesses.
4. Connect female end #2 and male end #6 to energize release valves.
  - a. If gate lowers down:
    - Check toggle switch harness and gray 3 wire harness for any damage.
  - b. If gate does not lower down:
    - Check both release valve wires for any damage.
    - Unscrew plugs of valves and stick a voltmeter into plugs and hit the down function. Check each connection for voltage.
      - If the voltmeter reads a voltage the cable is not damaged.
      - If the voltmeter shows 0 volts, the cable is damaged.
  - c. Remove the plastic cap of the release valves – keep coil in place- hold a screwdriver close to steel valve stem while pressing the down function on the toggle switch – if screwdriver did not get magnetically pulled towards the valve, the coil is bad.

\*Note: Please see chapter 11.6 for the Wiring Diagram details.

## 11.3 Liftgate Does Not Lift Up

1. Visually check the valves at cylinders for mechanical damage such as bent or broken valves.
2. Jump female end of cable #2 to small positive connector on motor solenoid



Do NOT stay between platform and truck body, gate will raise up



3. Gate is raising up – Check toggle switch harness and gray wire harness to switch for damaged spots.
4. If gate does not raise up:
  - a. Check the motor solenoid for proper function and listen for clicking.
    - No clicking = Motor solenoid or thermo switch at motor is bad.
    - Clicking = Check for voltage on both big positive studs to ground. If voltage is present the solenoid is ok. If not, the solenoid is not connecting internally and is bad.
  - b. Motor Solenoid is ok:
    - Check for power on large positive motor stud.
    - If no power is present, either the motor or the brushes are bad. If there is no power at the motor stud, check the connection to the solenoid.

If gate is still not working, take truck/trailer and gate to an authorized repair station

\*Note: Please see chapter 11.6 for the Wiring Diagram details.

## 11.4 Electrical Wiring – Batteries – Truck/Trailer

\*Resettable Circuit Breaker: 150 Amp Min. **Replace with same amperage breaker when necessary.**

Ground: For optimal grounding, ground all batteries and power units to the body side rails of the vehicle.

**NOTICE: DO NOT attempt to jump in-line fuses with other objects other than the specified fuse.**

**Do not increase the amperage rating of fuse. Serious harm to the liftgate will result when standard practices are not followed.**

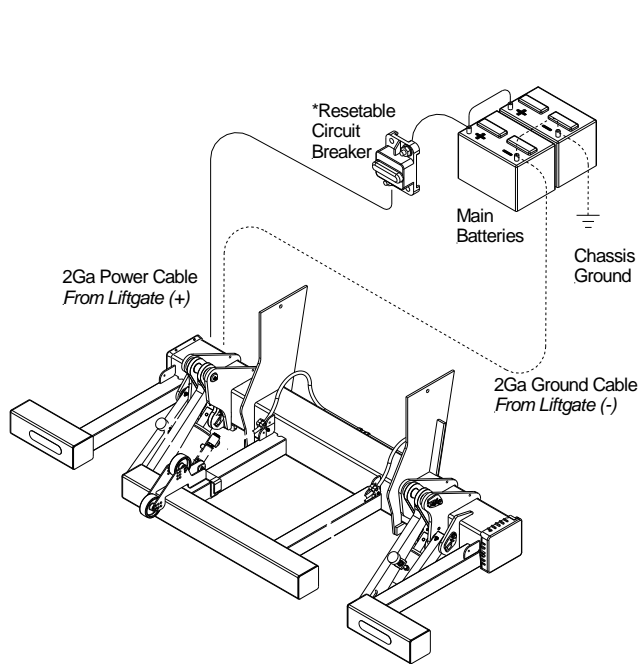

Wiring Diagram – All Others

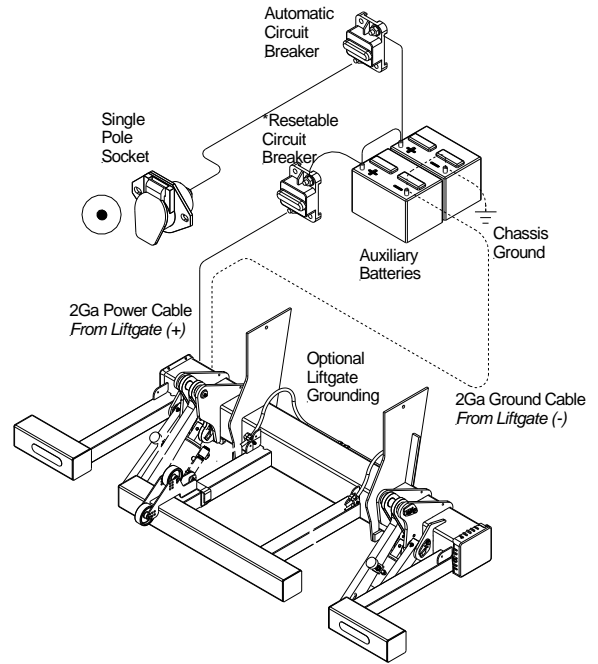

Wiring Diagram – Single Pole - Trailer

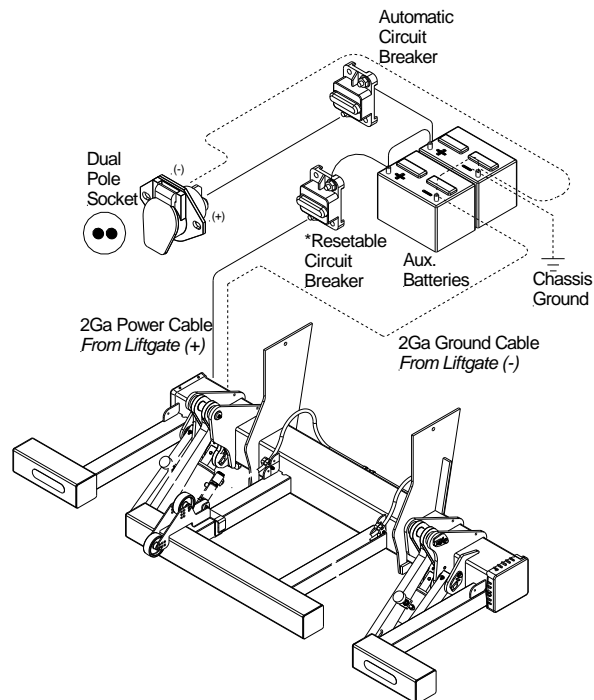

Wiring Diagram – Dual Pole - Trailer

## 11.5 Trailer to Tractor Ground Test

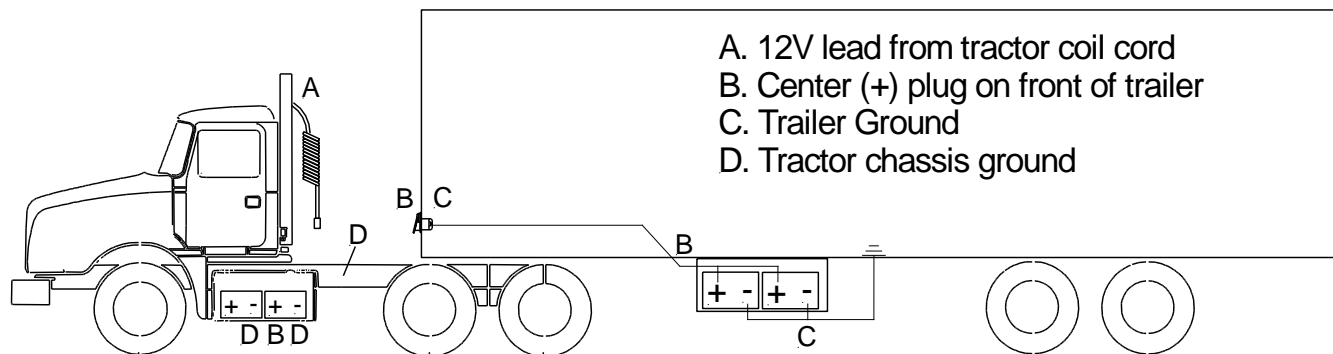

Testing of full system using a battery load tester. Start with testing each individual battery on both tractors and trailer before proceeding to check the system:

### 1. Tractor Test:

- Ground battery load tester on tractor chassis point (D)
- Connect positive load tester cable on positive pole of single pole plug at end of tractor coil cord (A)
- Run load test- This will test entire circuit on tractor including ground

### 2. Trailer Test:

- Ground battery load tester on trailer chassis point (C)
- Connect positive cable on positive pole of single pole plug receptacle on trailer (B).
- Run load test- This will test entire circuit on tractor including circuit breakers and ground between trailer batteries and trailer chassis.

### 3. Tractor and Trailer Charging system test while connected:

- Ground battery load tester on tractor chassis point (D)
- Connect positive cable on positive pole of single pole plug receptacle on trailer (B).
- Run load test- This will test entire circuit on tractor and trailer including ground between tractor, trailer, and circuit breaker on trailer.

A simple low amp voltage test at the front of the trailer or at the tractor will not show insufficient connections or ground problems.

# 11.6 Wiring Diagram (Power Down)

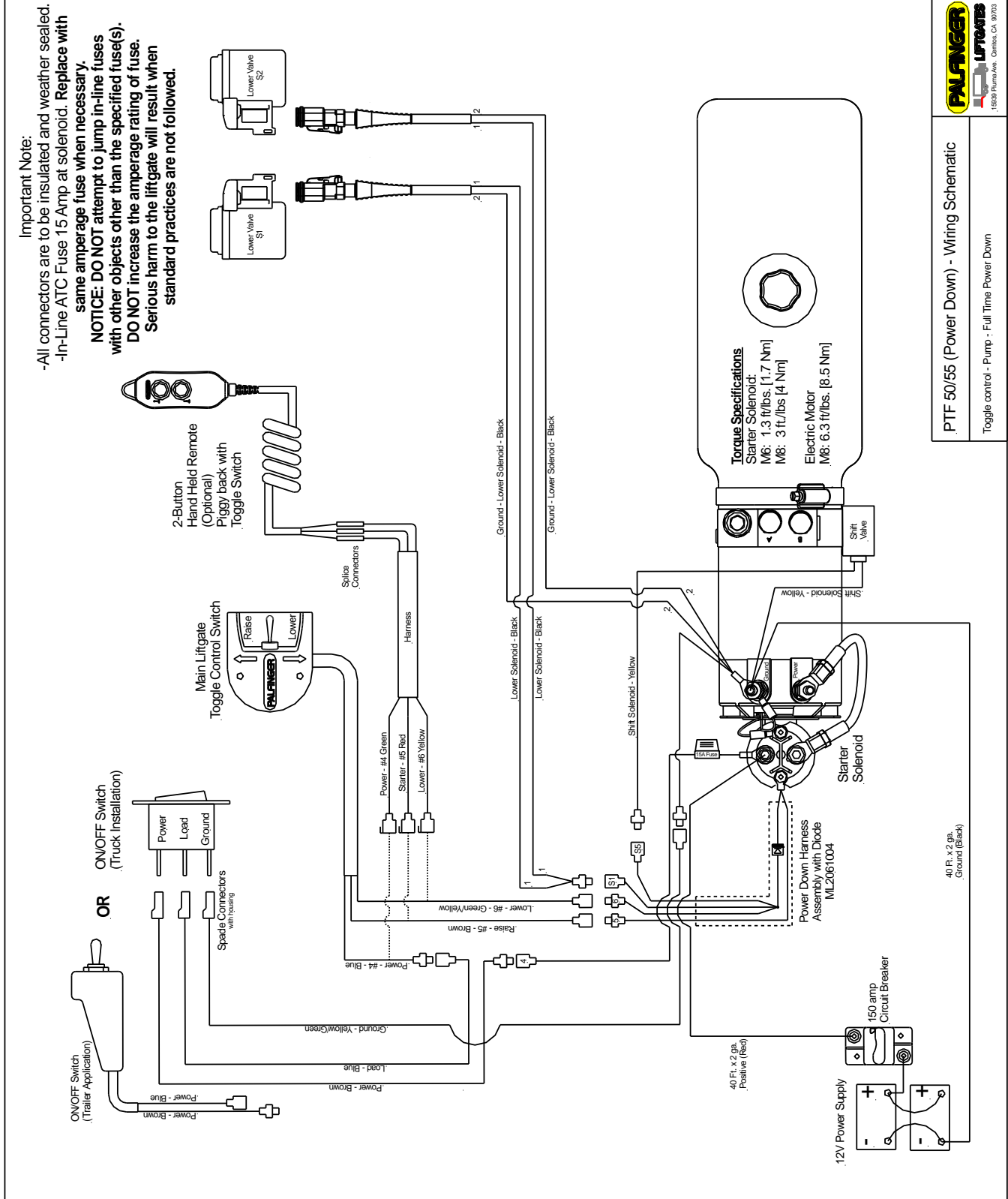

**FALANGER**  
**LIFTGATES**  
 19289 Puma Ave. - Corona, CA 92703

**PTF 50/55 (Power Down) - Wiring Schematic**

Toggle control - Pump : Full Time Power Down



### 11.7 Hydraulic Schematics (Power Down)

S1 & S2 - Release Valve for Lowering  
 R1 & R2 - Flow Restrictor for limiting lower speed.  
 S5 - Shift Valve is activated upon LOWER function only.  
 Pilot to close check valve is NOT used on Power Down.

Raise = M  
 Power Down = M + S1&2 + S5

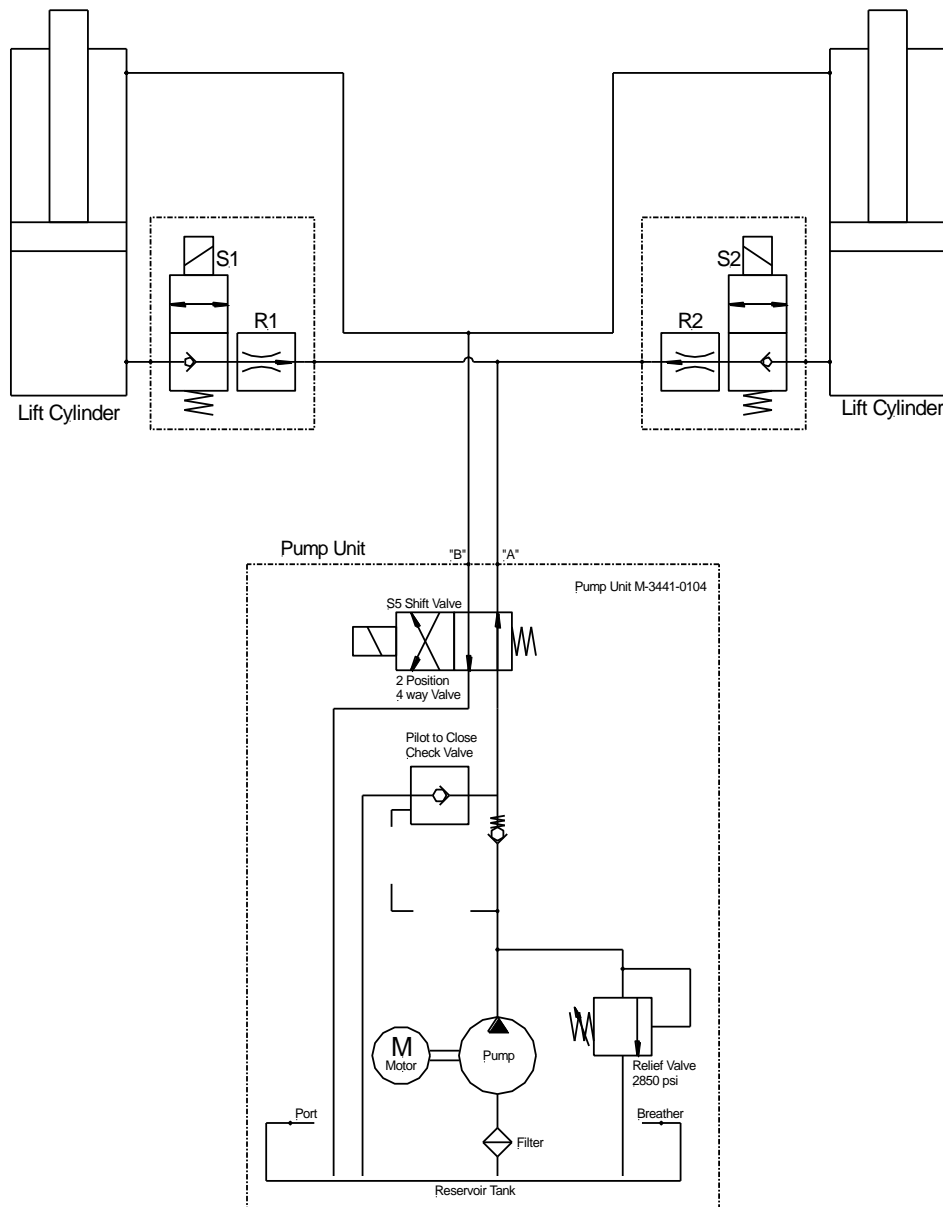

PTF Hydraulic Schematic  
 Power Down



## 12 Needed Information for Ordering Spare Parts and Repairs

### 12.1 Ordering Spare Parts

In order to assure quick delivery of spare parts, please always state the following information when making orders:

1. Liftgate model & serial number.
2. Designation and number of the spare part in accordance with the spare parts list.
3. Designation and number marked on the individual component (if available).

### 12.2 Repairs

Parts sent to INTERLIFT Liftgates to repair must be accompanied by a letter (in separate cover) giving details and scope of the repairs required.

## 13 Warranty

INTERLIFT Liftgates provides warranty as part of its conditions of delivery. Spare part deliveries are first of all billed. INTERLIFT Liftgates then issues credit for all or part of the invoiced sum when INTERLIFT Liftgates has been able to determine that the warranty claim is justified as defined by its warranty conditions. INTERLIFT Liftgates does this by inspecting the defected parts which are sent back to INTERLIFT Liftgates freight-prepaid as well as the written description of the problem which must have been filled out in full.

The parts that are sent back to INTERLIFT Liftgates, marked with serial number and address, become INTERLIFT Liftgates' property if the warranty claim is accepted.

All warranty claims must be received **within 30 days** of repair or replacement. Including the following information:

1. Liftgate model.
2. Liftgate serial number.
3. Description of problem.
4. Itemized bill of repair with breakdown of number of hours to perform warranty work and labor changes per repair.
5. Parts used for repair with INTERLIFT Liftgates part number.
6. RMA#.
7. Contact INTERLIFT Liftgates, if applicable.

Model	Pump and Motor	Cylinders	Hardware	Control System	Hydraulic
PTF 50/55	2 yrs	3 yrs	3 yrs	3 yrs	2 yrs

**14 Contact Address**

15939 Piuma Ave  
Cerritos, CA 90703  
Phone: (562)-924-8218  
Fax: (562)-924-8318

E-mail (parts order):  
[liftgateparts@palfinger.com](mailto:liftgateparts@palfinger.com)

E-mail (technical support):  
[technicalapplications@palfinger.com](mailto:technicalapplications@palfinger.com)



572 Whitehead Road  
Trenton, NJ 08619  
Phone: (609)-587-4200  
Fax: (609)-587-4201

E-mail (parts order):  
[liftgateparts@palfinger.com](mailto:liftgateparts@palfinger.com)

E-mail (technical support):  
[technicalapplications@palfinger.com](mailto:technicalapplications@palfinger.com)