

# **ILQ K1 PLUS**

## **TROUBLESHOOTING GUIDE**

# ILQ-K1Plus – Series (July 2008-today)

## Troubleshooting: K1Plus with square circuit board

<u>Table of content:</u>	<u>Page</u>
1) Gate overview and connector setup.....	2
2) Gate does not tilt open up.....	3
3) Gate is not lowering down.....	4
4) Gate is not auto tilting down at ground level.....	5
5) Gate is not tilting up at ground level.....	6
6) Gate is not lifting up.....	7
7) Gate is not closing.....	8
8) Electrical schematic.....	9
9) Hydraulic schematic.....	10

### Tools needed:

- 1.) Voltmeter
- 2.) Test light
- 3.) 8" jumper cable (16ga. or smaller)
- 4.) Screw driver flat head or 13mm (1/2") wrench

**\*\*\*\*\*MAKE SURE YOUR BATTERIES ARE FULLY CHARGED  
AND IN GOOD CONDITIONS\*\*\*\*\***

# Overview of liftgate and schematic of circuit board

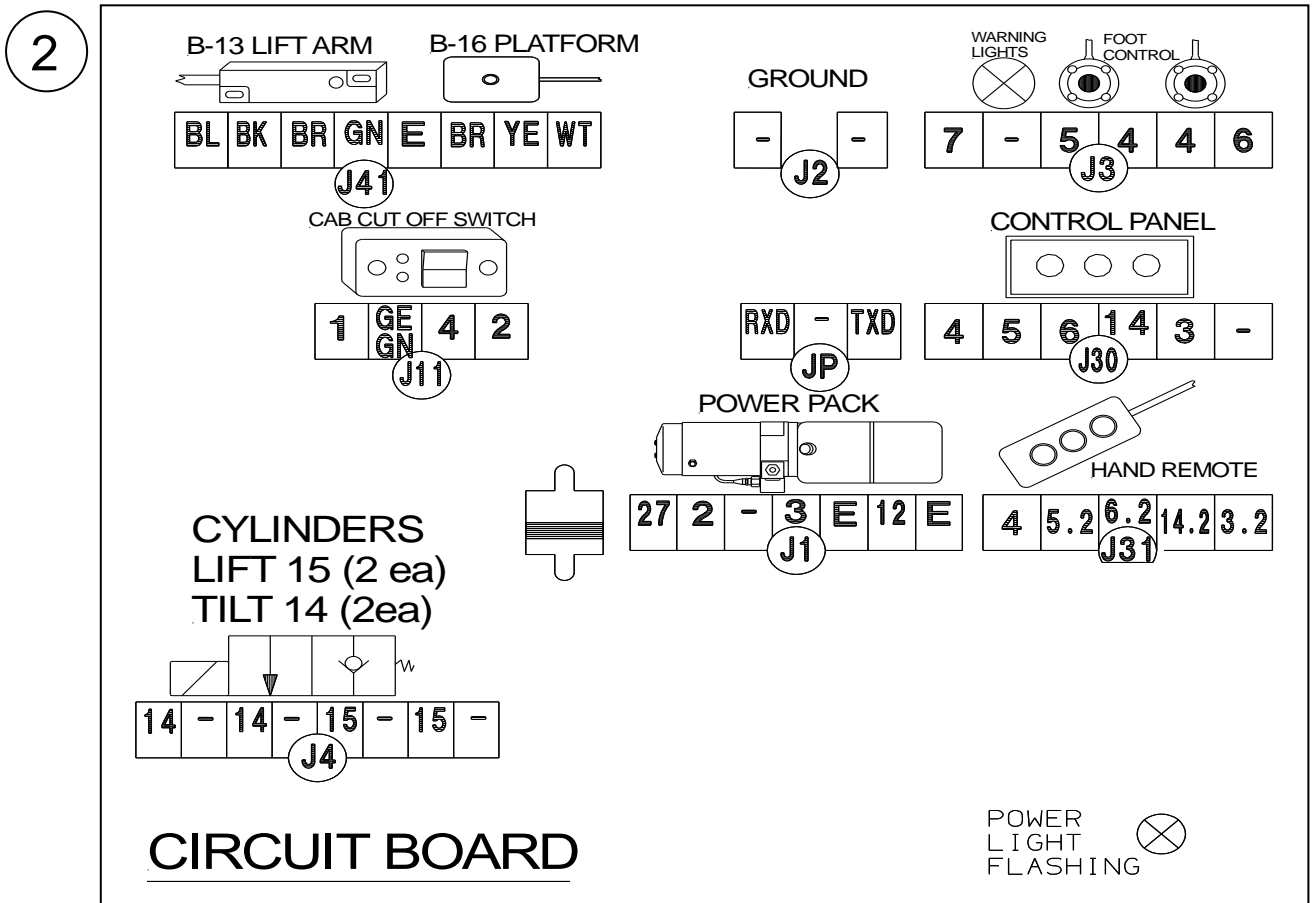
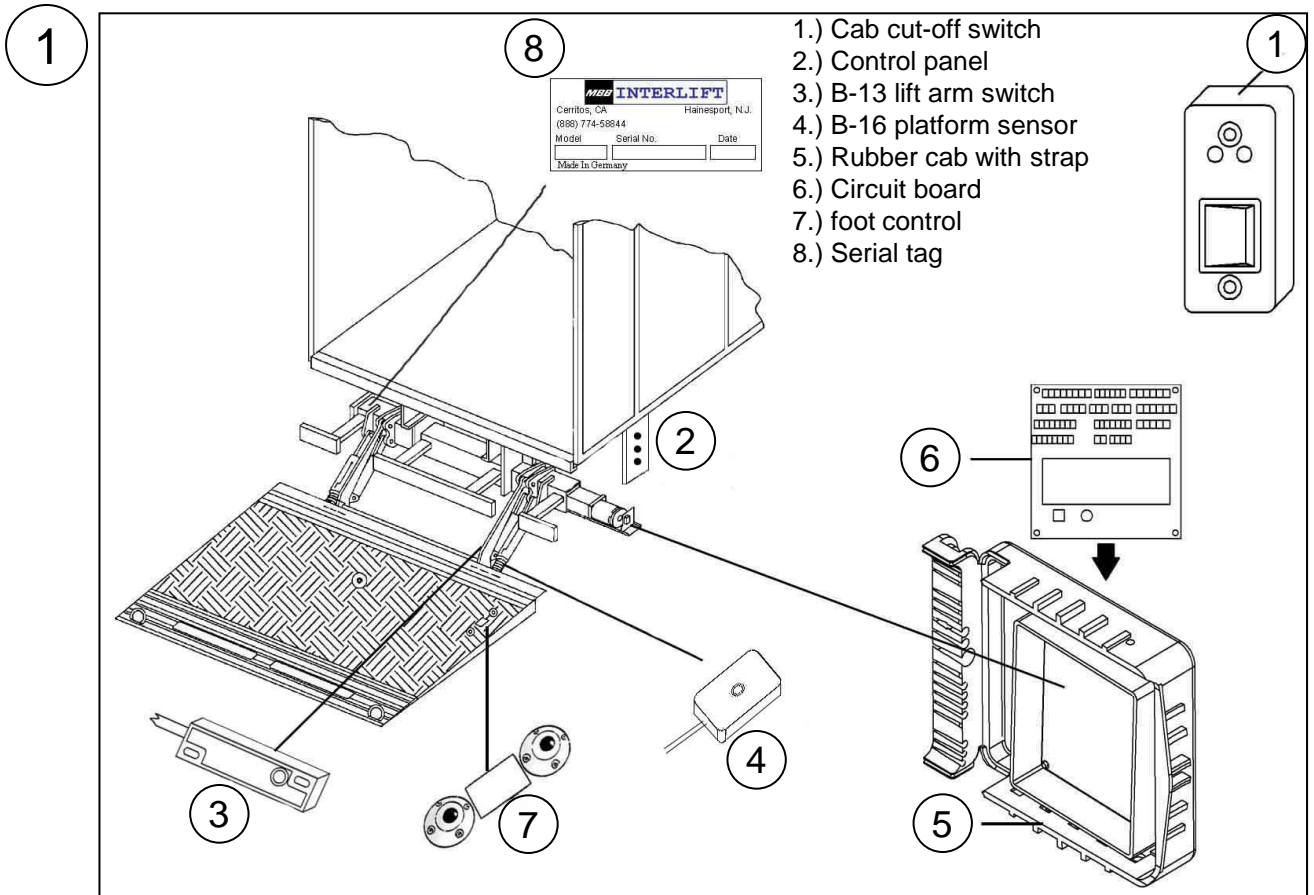

# 1) GATE DOES NOT TILT OPEN UP



ILQ+  
Series

## 1.1) Check Battery Power

- Check resettable Circuit Breaker on top of batteries → Push Reset Tab back in, if popped out
- Check fuse on top of batteries (qty 1) and at circuit board (qty 2) behind rubber cover on passenger side
- Start truck and run engine in fast idle for charging the battery  
→ if liftgate starts working, recharge batteries → test batteries and truck charging system
- Check power on board between J-11 #4 and J-2 (-) with voltmeter by pushing the up-function knob and hold for 10 sec with gate in stored position (DEADHEAD GATE) (above 10 Volt is necessary for proper use of liftgate) → less than 10 V; Jump #2 to #4 on J-11 → voltage jumps more than 1 volt, call Palfinger for assistance

**\*\*\*\*DO NOT LEAVE JUMPER ON J-11 – GATE MUST BE SHUT OFF WHEN NOT IN USE\*\*\*\***

## 1.2) Check for short in optional equipment

- Unplug J-3(w/l and f/c), J-41(B-13, B16, **jump J-11 #4 to J-41 #GN**) and J-31(Hand control)  
Keep the 3 connectors unplugged (gate will operate without plugs connected, loose auto tilt)
- Unplug J-1 (Main power), wait 10 seconds and plug J-1 back to the board (Reset the board)
- Plug each connector back, one at a time and check functions of gate after plugging in each

## 1.3) Check voltage supply to release valves on tilt cylinder

- Check voltage at J4 #14 and Ground J-2 #(-) while pushing the tilt knobs for opening up the release valves at the tilt cylinders. No Voltage → check for bad knobs or loose wire to control panel
- Listen for clicking of the release valves at the tilt cylinders (outer cylinders)  
- If valves are not clicking → check wire for damaged spots, loose connections or a bad valve

## 1.4) Check motor solenoid power

- Check voltage at J-1 #3 and Ground J-2 #(-) while pushing knobs to engage motor solenoid  
No voltage → board might be damaged
- Check voltage at small motor solenoid studs and Ground J-2 #(-) while pushing knobs and listen for clicking of the motor solenoid – no voltage or clicking → check wire to motor solenoid
- Check for voltage across the small motor solenoid studs with test light while pushing knobs  
See a light → power is reaching solenoid.
- Check for main power at the big solenoid studs, one has voltage; if not check connections to battery
- Check both big solenoid studs for voltage while pushing the opening knobs → if not → solenoid is bad
- Jump large terminals at motor solenoid
  - If motor runs → motor solenoid is bad
  - If motor does not run → Bad motor or bad ground
  - Tap on motor → motor starts running – bad brushes

## 2) GATE IS NOT LOWERING DOWN



### 2.1) Check Battery Power

- Check resettable Circuit Breaker on top of batteries → Push Reset Tab back, if popped out.
- Check fuse on top of batteries (qty 1) and at circuit board (qty 2) behind rubber cover on passenger side
- Start truck and run engine in fast idle for charging the battery → if liftgate starts working, recharge batteries → test batteries and truck charging system
- Check power on board between J-11 #4 and J-2 #(-) with voltmeter by pushing the up-function knob and hold for 10 sec with gate in stored position (DEADHEAD GATE) (above 10 Volt is necessary for proper use of liftgate) → less than 10V; Jump #2 to #4 on J-11 → voltage jumps more than 1 volt, call Palfinger for assistance

\*\*\*\***DO NOT LEAVE JUMPER ON J-11 – GATE MUST BE SHUT OFF WHEN NOT IN USE**\*\*\*\*

### 2.2) Check for short in optional equipment

- Unplug J-3(w/l and f/c), J-41(B-13, B16, **jump J-11 #4 to J-41 #GN**) and J-31(Hand control) Keep the 3 connectors unplugged (gate also operates without plugs connected, loose auto tilt)
- Unplug J-1 (Main power), wait 10 seconds and plug J-1 back to the board (Reset the board)
- Plug each connector back one at a time and check functions of gate after plugging in each

### 2.3) Check voltage supply to release valves on lift cylinder

- Check voltage between Ground J-2 #(-) to J4 #15 while pushing the lowering knob for opening the release valves at the lift cylinders. No voltage → check for bad knob or loose wire at control panel
- Listen for clicking of the release valves at the lift cylinder (inner cylinders) → If valves are not clicking → check wire for damaged spots or loose connections

### 2.4) Gate is lowering down very slowly → S5 at motor not engaged

- Check Voltage at J1 #12 and Ground J-2 #(-) while pushing knob to engage the shift valve at the pump and motor inside the main tube
- Override the shift valve by pushing down the center brass pin with small Phillips screwdriver while pushing the down knob → Gate will lower down → check the valve and look for damaged wire or loose connections

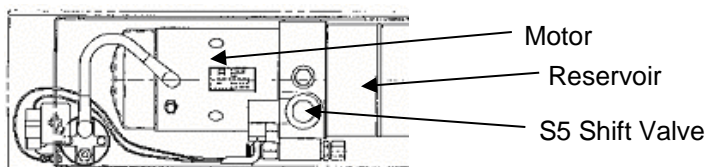

### 3) GATE IS NOT AUTO TILTING AT GROUND LEVEL



ILQ+  
Series

#### 3.1) Check Battery Power

- a) Check resettable Circuit Breaker on top of batteries → Push Reset Tab back in, if popped out
- b) Check fuse on top of batteries (qty 1) and at circuit board (qty 2) behind rubber cover on passenger side
- c) Start truck and run engine in fast idle for charging the battery → if liftgate starts working, recharge batteries → test batteries and truck charging system
- d) Check power on board between J-11 #4 and J-2 #(-) with voltmeter (above 10 Volt is necessary for proper use of liftgate) → less than 10V; Jump #2 to #4 on J-11 → voltage jumps more than 1 volt, call Palfinger for assistance

**\*\*\*\*DO NOT LEAVE JUMPER ON J-11 – GATE MUST BE SHUT OFF WHEN NOT IN USE\*\*\*\***

#### 3.2) Check adjustment of auto-tilt sensor B-13

- a) Check the position of the B-13 Sensor on the inside of the passenger side liftarm → Sensor has to be in a horizontal position when gate is 8"-10" above ground
- b) Check if the outer J41 Plug is loose (color sequence = blue, black, brown)

#### 3.3) Check function of control panel or hand control

- a.) Check voltage at J30 #4 to Ground J-2 #(-) for power supply of the control panel
- b) Check voltage at J30 #6(lower) to Ground J-2 #(-) for lowering signal by pushing down knob → Signal on J30 #6 → control panel is ok; if no signal → check for damaged wire or loose cables inside control panel or damaged knob

#### 3.4) Check voltage supply to release valves on tilt cylinder

- a) Check voltage at J41 #(BLACK)(B-13) to Ground J-2 #(-) while platform is on ground → 12V
- b) Check voltage at J41 #(BLUE)(B-13) to Ground J-2 #(-) while platform is on ground → 12V → No voltage on BLUE → Look for damaged spots or loose connection or B-13 is bad
- c) Check voltage at Ground J-2 #(-) to J4 #14 while pushing the lowering knob when gate is on ground for opening up the release valves at the tilt cylinders
- d) Listen for clicking of the release valves at the tilt cylinder (outer cylinders) → If valves are not clicking → check wire for damaged spots or loose connections



## 4) GATE IS NOT TILTING UP AT GROUND

### 4.1) Check Battery Power

- a) Check resettable Circuit Breaker on top of batteries → Push Reset Tab back in, if popped out
  - b) Check fuses on top of batteries (qty 1) and at circuit board (qty 2) behind rubber cover on passenger side
  - c) Start truck and run engine in fast idle for charging the battery  
→ if liftgate starts working, recharge batteries → test batteries and truck charging system
  - d) Jump #2 to #4 on J-11 → voltage jumps more than 1 volt, call Palfinger for assistance
- \*\*\*\*DO NOT LEAVE JUMPER ON J-11 – GATE MUST BE SHUT OFF WHEN NOT IN USE\*\*\*\***

### 4.2) Check function of control panel or hand control

- a) Check voltage at J30 #4 to Ground J-2 #(-) for power supply of the control box
- b) Check voltage at J30 #5(lift) to Ground J-2 #(-) for lifting signal by pushing up button  
→ Signal on J30 #5 → control panel is ok; if no signal check for damaged wire or loose cables inside control panel or damaged turn knob

### 4.3) Check motor solenoid power to run the motor

- a) Check voltage at J-1 #3 to Ground J-2 #(-) while pushing lift knob to engage motor solenoid
- b) Check for voltage at small motor solenoid studs and Ground while pushing knob and listen for clicking of the motor solenoid – no voltage or clicking → check wire to motor solenoid
- c) Check for voltage across the small motor solenoid studs with test light while pushing knob  
→ See a light → power is reaching solenoid.
- d) Check for main power at the big solenoid studs, one has voltage; if not check connections to battery
- e) Check both big solenoid studs for voltage while pushing the opening knob → if not → solenoid is bad
- f) Jump large terminals at motor solenoid
  - If motor runs → motor solenoid is bad
  - If motor does not run → Bad motor or bad ground
  - Tap on motor → motor starts running – bad brushes

### 4.4) Check function of shift valve S5 at pump & motor

- a) Check voltage at J1 #12 and Ground J-2 #(-) while pushing knob to engage the shift valve at the pump and Motor inside the main tube
- b) While pushing the knob to make the motor run, override shift valve by pushing the center brass pin with small Phillips screwdriver  
→ Gate will tilt up, if not → check the valve and look for damaged wire or loose connections

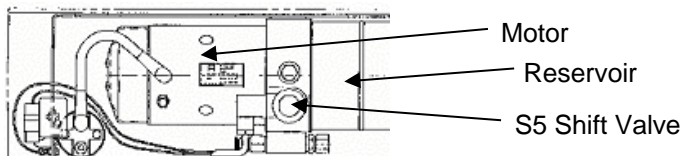

## 5) GATE IS NOT LIFTING UP



ILQ+  
Series

### 5.1) Check Battery Power

- Check resettable Circuit Breaker on top of batteries → Push Reset Tab back in, if popped out.
- Check fuse on top of batteries (qty 1) and at circuit board (qty 2) behind rubber cover on passenger side
- Start truck and run engine in fast idle for charging the battery  
→ if liftgate start working, recharge batteries → test batteries and truck charging system
- Check power on board between J-11 #4 and J-2 #(-) with voltmeter (above 10 volt is necessary for proper use of liftgate) → less than 10V; Jump #2 to #4 on J-11 → voltage jumps more than 1 volt, call Palfinger for assistance

**\*\*\*\*DO NOT LEAVE JUMPER ON J-11 – GATE MUST BE SHUT OFF WHEN NOT IN USE\*\*\*\***

### 5.2) Check function of control panel(J-30) and hand control(J-31)

- Check voltage at J30 #4 to Ground J-2 #(-) for power supply of the control panel
- Check voltage at J30 #5(lift) to Ground J-2 #(-) for lifting signal  
→ Signal on J30 #5 → control panel is ok; if no signal check for damaged wire or loose cables inside control panel or damaged knob

### 5.3) Check for short in optional equipment

- Unplug J-3(w/l and f/c), J-41(B-13, B16, **jump J-11 #4 to J-41 #GN**) and J-31(Hand control) Keep the 3 connectors unplugged (gate also operates without plugs connected)
- Unplug J-1 (Main power), wait 10 seconds and plug J-1 back to the board (Reset the board)
- Plug each connector back one at a time and check functions of gate after plugging in each.

### 5.4) Check motor solenoid power to run the motor

- Check for voltage at J-1 #3 to Ground J-2 #(-) to engage motor solenoid while pushing lift knob
- Check for voltage at small motor solenoid studs to Ground J-2 #(-) while pushing knob and listen for clicking of the motor solenoid – no voltage or clicking → check wire to motor solenoid
- Check voltage across the small motor solenoid terminals with test light while pushing knob  
See a light → power is reaching solenoid
- Check for main power at the large solenoid studs, one has voltage; if not check connections to battery
- Check both big solenoid studs for voltage while pushing the opening knob → if not → solenoid is bad
- Jump large terminals at motor solenoid
  - If motor runs → motor solenoid is bad
  - If motor does not run → Bad motor or bad ground
  - Tap on motor → motor starts running – bad brushes



## 6) GATE IS NOT CLOSING

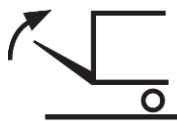

### 6.1) Check Battery Power

- Check resettable Circuit Breaker on top of batteries → Push Reset Tab back in, if popped out
- Check fuse on top of batteries (qty 1) and at circuit board (qty 2) behind rubber cover on passenger side
- Start truck and run engine in fast idle for charging the battery  
→ if liftgate start working, recharge batteries → test batteries and truck charging system
- Check power on board between J-11 #4 and J-2 #(-) with voltmeter by pushing the up-function knob and hold for 10 sec with gate in stored position (DEADHEAD GATE) (above 10 Volt is necessary for proper use of liftgate) → less than 10V; Jump #2 to #4 on J-11 → voltage jumps more than 1 volt, call Palfinger for assistance

**\*\*\*\*DO NOT LEAVE JUMPER ON J-11 – GATE MUST BE SHUT OFF WHEN NOT IN USE\*\*\*\***

### 6.2) Check function of control panel(J-30) and hand control(J-31)

- Check voltage at J30 #4 to Ground J-2 #(-) for power supply of the control panel
- Check voltage at J30 #3(close) to Ground J-2 #(-) for lifting signal by pushing the buttons.  
→ Signal on J30 #3 → control panel is ok; if no signal, check for damaged wire or loose cables inside control panel or damaged knob

### 6.3) Check for S5 valve on pump & motor not engaged

- Check Voltage at J1 #12 and Ground J-2 #(-) while pushing knob to engage the shift valve at the pump and motor inside the main tube
- Override the shift valve by pushing down the center brass pin with small Phillips screwdriver while pushing the knob  
→ Gate will close up → check the valve and look for damaged wire or loose connections

### 6.4) Check motor solenoid power to run the motor

- Check voltage at J-1 #3 and Ground J-2 #(-) to engage motor solenoid while pushing lift knob
- Check voltage at small motor solenoid studs and Ground J-2 #(-) while pushing knob and listen for clicking of the motor solenoid – no voltage or clicking → check wire to motor solenoid
- Check voltage across the small motor solenoid terminals with test light while pushing knob  
See a light → power is reaching solenoid
- Check main power at the large solenoid studs, one has voltage; if not check connections to battery
- Check both big solenoid studs for voltage while pushing the opening knob → if not → solenoid is bad
- Jump large terminals at motor solenoid
  - If motor runs → motor solenoid is bad
  - If motor does not run → Bad motor or bad ground
  - Tap on motor → motor starts running – bad brushes

# Electrical schematic

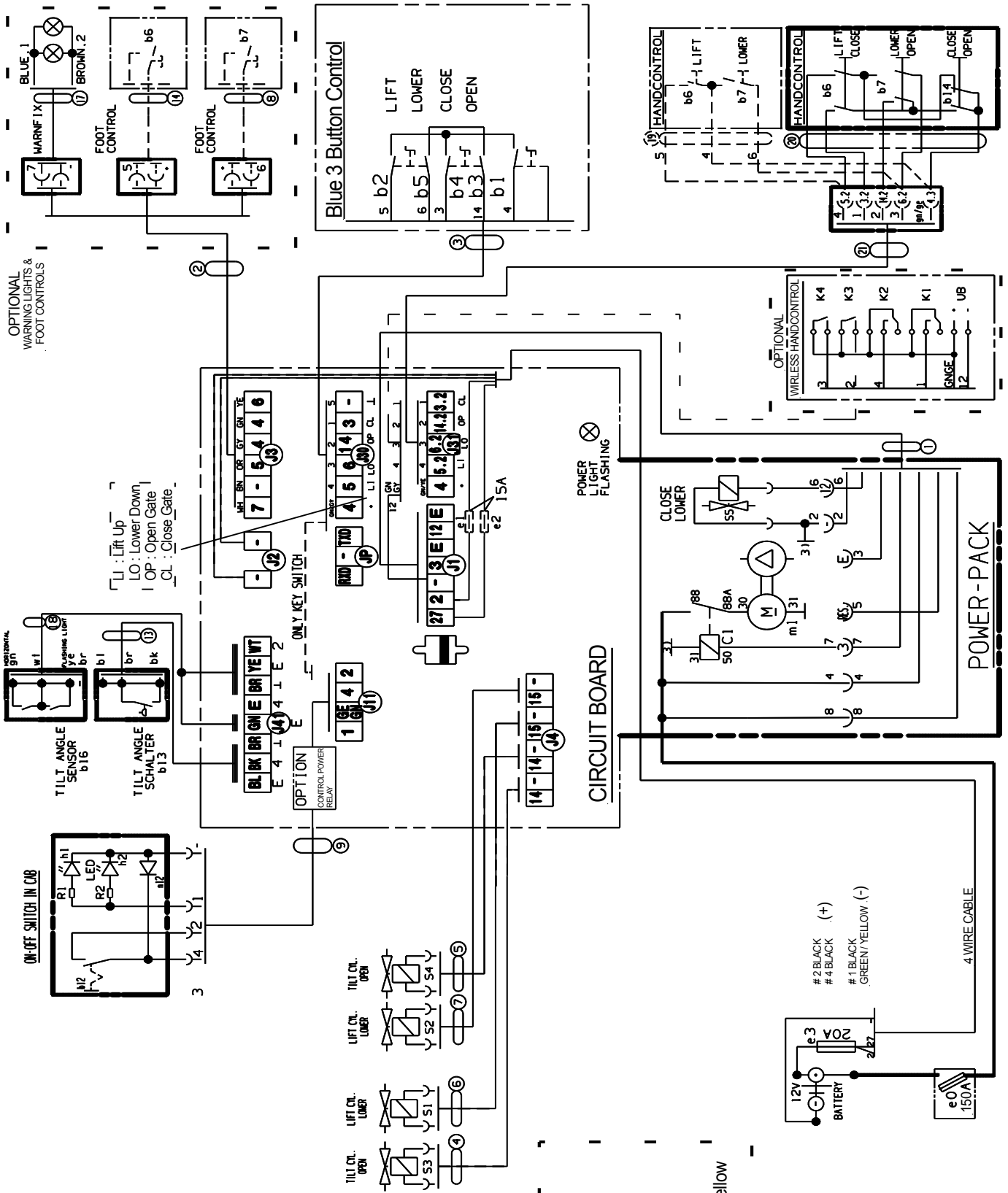

**Legend:**

- gn : green
- bl : blue
- br : brown
- wt : white
- ye : yellow
- bk : black
- gy : green-yellow

**ILQ  
K1Plus  
Series**

# Hydraulic schematic

Functions:

S1 and S2 = Release Valve for lowering function

S3 and S4 = Release Valve for tilt down function

R1 and R2 = Flow Restrictor located inside hose adaptor on lift cylinder

R3 and R4 = Flow Restrictor located inside hose adaptor on tilt cylinder

S5 = Shift Valve is activated on tilt up and lowering function

R5 = Restrictor Valve located in power pack

Flow Divider is activated, when fluid is going back into the power pack

If Flow Divider is loose or hanging up the fluid is circulated back in to tank

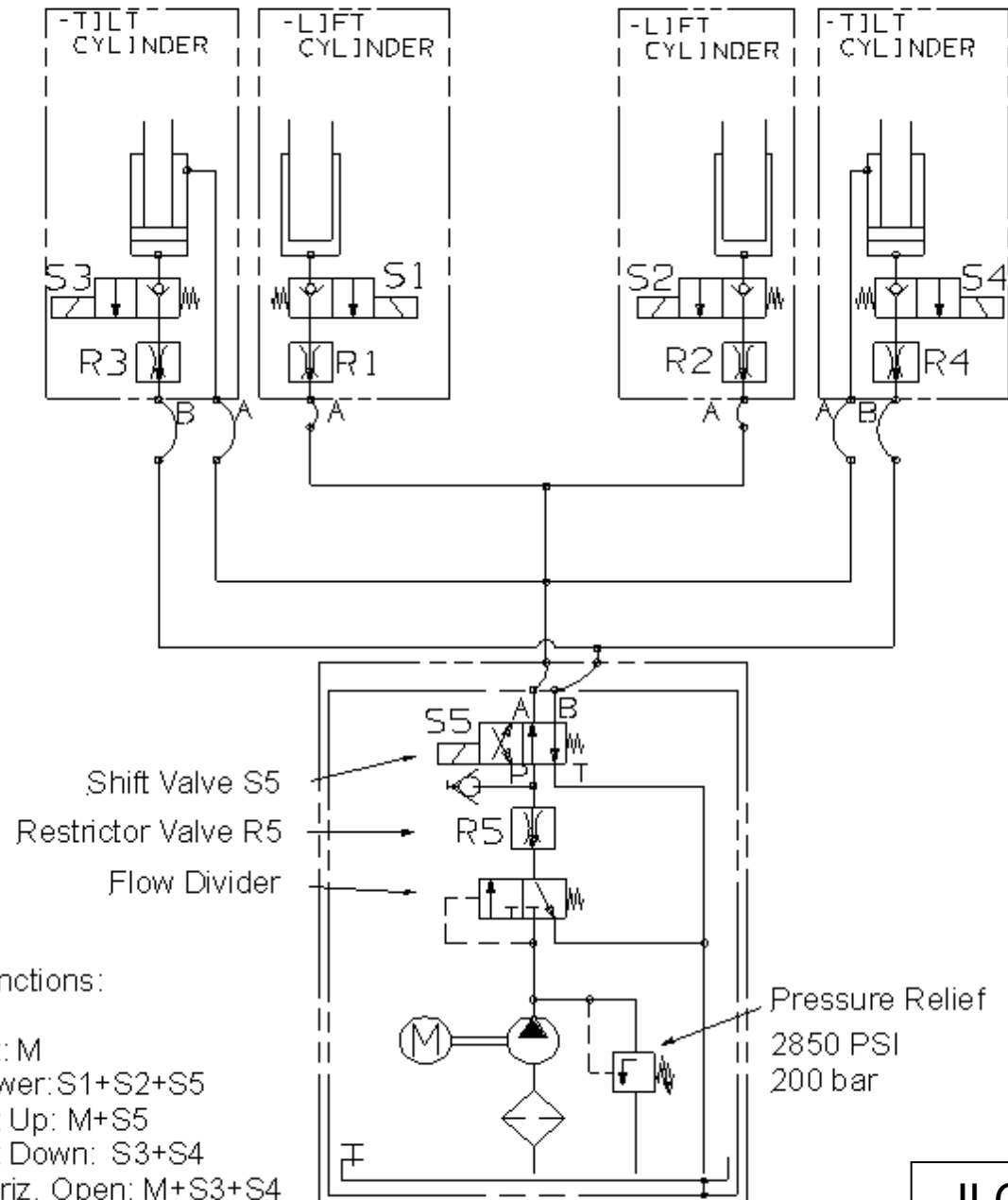

ILQ+  
Series